

The HOIST® Fitness Mi1 Home Gym is the newest edition to the Mi Series by HOIST® Fitness. The Mi1 provides the same premium look and feel HOIST® is known for matched with a minimalist design. This piece is great for users looking to get all the functionality of bigger gyms without taking up a significant amount of space.

### FEATURES



- ◆ Quick Release Adapters for easy one handed accessory adjustments.
- ◆ 150 lb. Silent Steel™ weight stack (upgradeable to 200 lbs.): Each solid steel individual plate receives pressed-in industrial plastic bushings and then is machined to exacting specifications to insure glass smooth operation plus eliminating any metal to metal contact or sound.
- ◆ Easy Glide™ inserts make adjustments quick, smooth and secure eliminating metal against metal contact & friction.
- ◆ Built in accessory holders.
- ◆ Compact multi-gym provides an uncompromised range of exercises commonly found in health clubs.

### HIGH PULLEY

- ◆ Lat bar pulldown and other high pull exercises.
- ◆ 1:1 cable ratio

### PRESS ARM - MID ROW

- ◆ Interchangeable press arm attachments allow you to do pressing exercises with either strap handles or articulating handles. Both allow you to control both the arc and angle of the exercise path. Chest, shoulder, abdominal & core exercises can be performed.
- ◆ Mid row handles offer a quality row pull exercise.

### LEG EXTENSION - STANDING LEG CURL

- ◆ Telescoping roller pad adjusts to provide proper positioning for leg extensions and standing leg curls.

Free HOIST® Strength app provides access to dozens of exercise tutorials, workout plans and fitness training



**FEATURES (CONT)****LOW PULLEY**

- ◆ Telescoping roller pad adjusts to provide proper positioning for seated biceps curls.
- ◆ 2:1 Split Weight Cabling™ ratio allows for a wide group of exercises to be performed here with 100% of the selected resistance.

**INCLUDED ACCESSORIES**

- ◆ Lat Bar
- ◆ Curl Bar
- ◆ Fleece Knee Strap
- ◆ Fleece Ankle Strap
- ◆ Strap Handles with 3 length choice rings
- ◆ Articulating Press Handles

**UPGRADES AVAILABLE FOR PURCHASE**

- ◆ V Stationary Leg Press
- ◆ V Ride Leg Press
- ◆ 50 lb. Silent Steel weight stack upgrade

**SPECS (L X W X H)**

76.75" X 48.25" X 83.50" (195 cm X 123 cm X 212 cm)

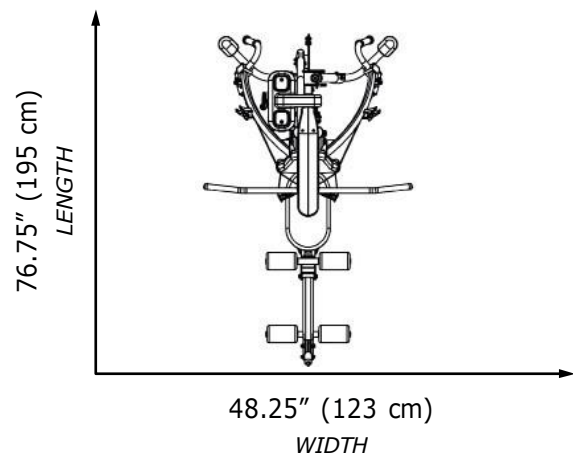
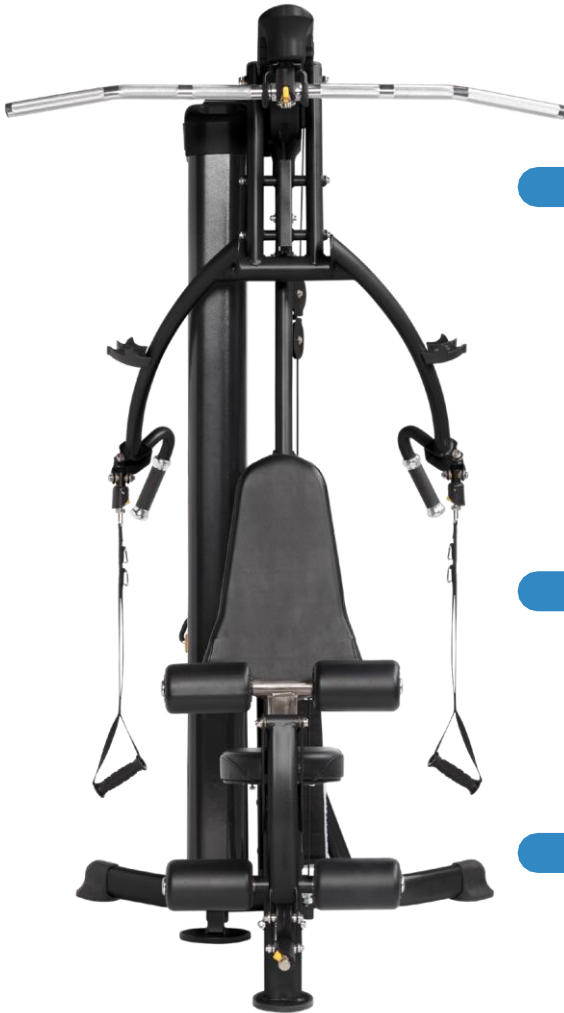

Free HOIST® Strength app provides access to dozens of exercise tutorials, workout plans and fitness training

