

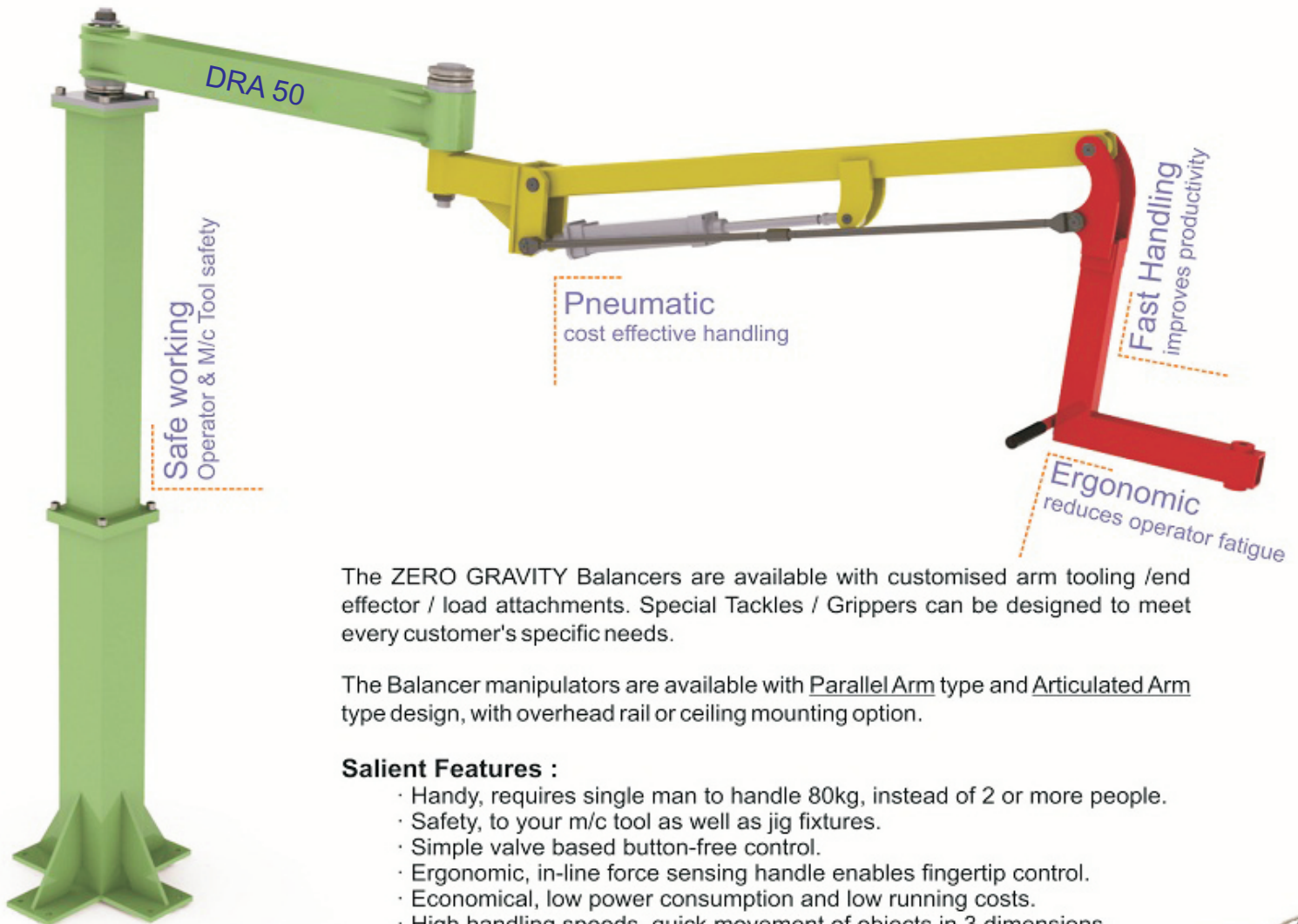

# Pneumatic ZERO GRAVITY BALANCER



The ZERO GRAVITY Balancers are available with customised arm tooling /end effector / load attachments. Special Tackles / Grippers can be designed to meet every customer's specific needs.

The Balancer manipulators are available with Parallel Arm type and Articulated Arm type design, with overhead rail or ceiling mounting option.

### Salient Features :

- Handy, requires single man to handle 80kg, instead of 2 or more people.
- Safety, to your m/c tool as well as jig fixtures.
- Simple valve based button-free control.
- Ergonomic, in-line force sensing handle enables fingertip control.
- Economical, low power consumption and low running costs.
- High handling speeds, quick movement of objects in 3 dimensions.
- Self-balancing, adjust to weight of the load.

### Benefits :

- Improvement in productivity
- Manpower saving
- Reduction of strain, stress and repetitive injuries.
- No damage to material being handled and Machine tool.

The most important reason to use our Balancer is safety of your employees.

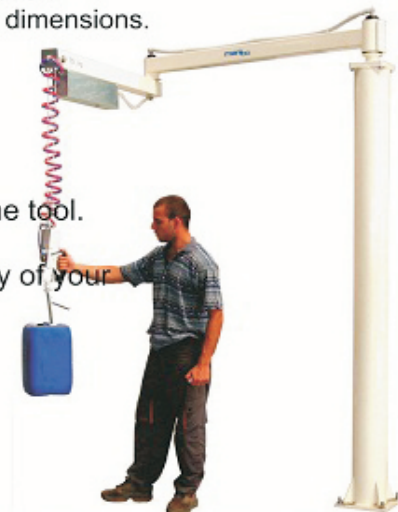
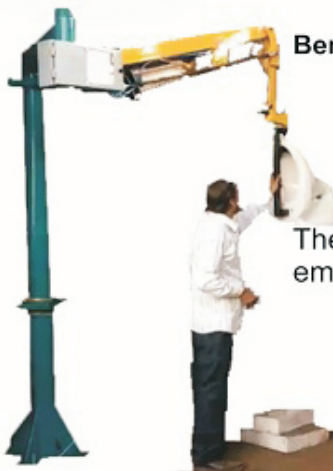

DRA 50

DRA 80

Balancing Capacity	50Kg	80 Kg
Covering Radius	2.7 meter	2.2 meter
Pressure	5.5 Bar	5.5 Bar
Lifting Height	2.2 meter	2.2 meter



# Pneumatic ZERO GRAVITY BALANCER

Core Shop

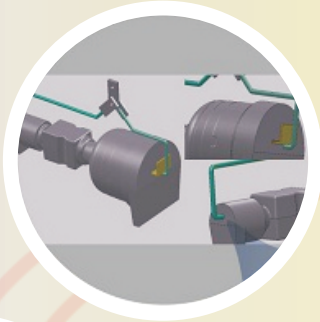

Application  
Areas

CNC / VMC  
HMC / VTM



Molding  
Line

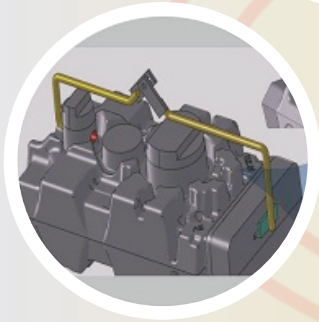

Packaging /  
Assembly  
Line



Inspection



## DRA 50 Pneumatic Balancer Manipulator:

Allows you to meet Standards and easily replace ineffective equipment such as hoist, cranes, etc. with a safer, more ergonomic solution.

Injuries results in more than lakhs of rupees as workers' compensation costs and employee's health hazard.

- lost production time
- loss of employee productivity and efficiency
- cost of rehiring and retraining employees
- product and machine tool damage costs

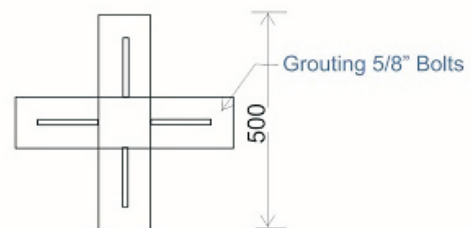
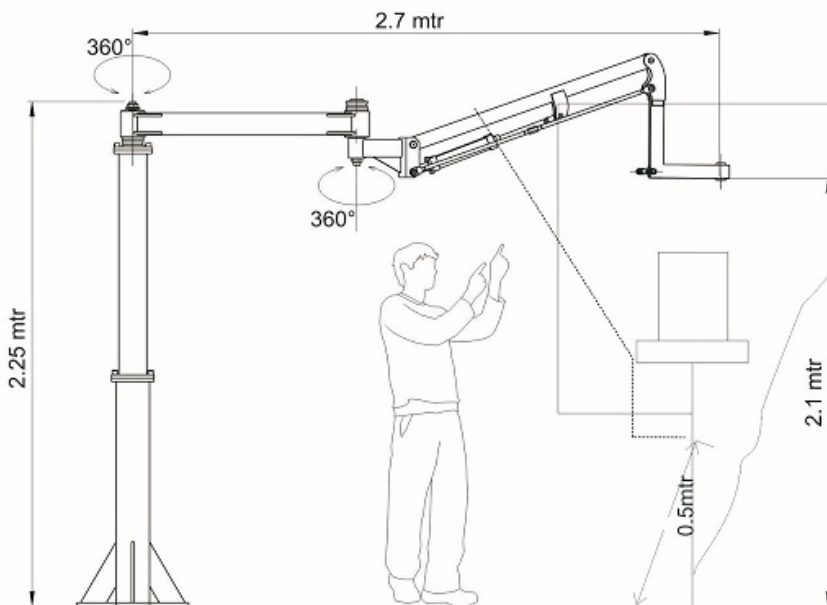

**HENDO INDUSTRIES**



ISO CERTIFIED COMPANY : 9001/14001/18001

Regd. Office : 303, 3rd Floor, Dadar Silver Sands Society, Near Janata Sahakari Bank Ltd., Agar Bazar,  
S. K. Bole Road, Dadar, Mumbai - 400 028.

Fact.: F-3, Ansa Industrial Estate, Sakivihar Road, Sakinaka, Andheri, Mumbai - 400 072.

Tel. : 4005 4256 / 57 • E-mail : [info@hendoindustries.com](mailto:info@hendoindustries.com) Website : [www.hendoindustries.com](http://www.hendoindustries.com)

Mr. Denver - 9819794744 • Mr. Keith (C.E.O.) - 9820214832 / 9930734532 • Skype - Keith0360