

FUNCTIONAL TRAINER

H-8

Big Performance. Compact Design. Transform your home gym or light commercial space with HOIST® Fitness H8 Functional Trainer—a powerful all-in-one solution engineered for efficiency, versatility, and style. Designed to fit seamlessly into a corner, the H8 saves space without sacrificing functionality. Built with HOIST®'s signature EZG cable columns, the H8 combines the smooth performance you expect with a fully integrated Smith machine, dedicated low row, lat pulldown stations, and built-in weight storage—all in one sleek, corner-friendly footprint. Whether you're training for strength, performance, or total-body fitness, the H8 delivers the tools you need, right where you need them.

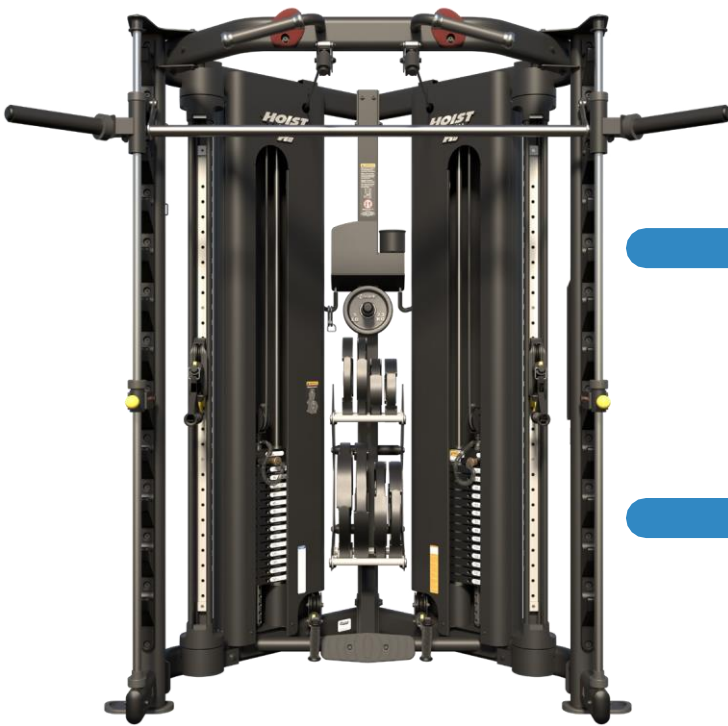

*WEIGHT PLATES SHOWN ARE NOT INCLUDED & SOLD SEPARATELY

EZG CABLE COLUMNS

- ◆ 180° rotating columns
- ◆ Patented single-handed Adjustment System
- ◆ Quick-Release Adaptors for rapid accessory changes
- ◆ 28 pulley adjustment points per column (independent or dual-side use)

SMITH MACHINE

- ◆ 12 rack-out positions
- ◆ Starting weight: 35 lbs. (16 kg)
- ◆ Max capacity: 450 lbs. (204 kg)
- ◆ Angled weight horns for compact loading

INTEGRATED PULLEY STATIONS

- ◆ 2 × Lat Pulldown pulleys
- ◆ 2 × Low Row pulleys
- ◆ Split Weight Cabling: Delivers 50% resistance for extended cable travel (Cable travel distance 85.00" (216 cm))

PULL-UP OPTIONS

- ◆ Standard chin-up bars
- ◆ Textured rock-climbing grips

WEIGHT SYSTEM

- ◆ Standard: 2 × 150 lbs. Silent Steel® stacks
Precision-machined steel plates with industrial plastic bushings
Fully enclosed for safety and noise reduction



Download the HOIST Strength App! (Visit hoistfitness.com/ scan on your smart phone to download a free QR Code Scanner.)

Free HOIST® Strength app provides access to dozens of exercise tutorials, workout plans and fitness training



WEIGHT SYSTEM (CONT)

- ◆ Optional Upgrade: 2 × 200 lbs. stacks (400 lbs. total)
- ◆ Weight Plate Storage Capacity: 300 lbs. (136 kg)

ACCESSORIES INCLUDED

- ◆ 2-to-1 Cable Adapter
- ◆ Two Strap Handles w/ Square D-Ring
- ◆ Fleece Knee Strap (1 D-Ring & 2 Square Rings)
- ◆ Chin Assist Strap (4" wide)
- ◆ Two Carabiner Adapters
- ◆ Aluminum Straight Bar Assembly
- ◆ Aluminum Curl Bar Assembly
- ◆ Aluminum Lat Bar
- ◆ Two Strap Handles w/ 3 Square Rings

ADDITIONAL FEATURES

- ◆ Central weight & accessory storage
- ◆ Integrated phone/tablet rack
- ◆ Water bottle holder
- ◆ Multiple hooks for organized attachment storage

SPECS (L X W X H)

56.00" X 80.00" X 83.50" (142 cm X 203 cm X 212 cm)

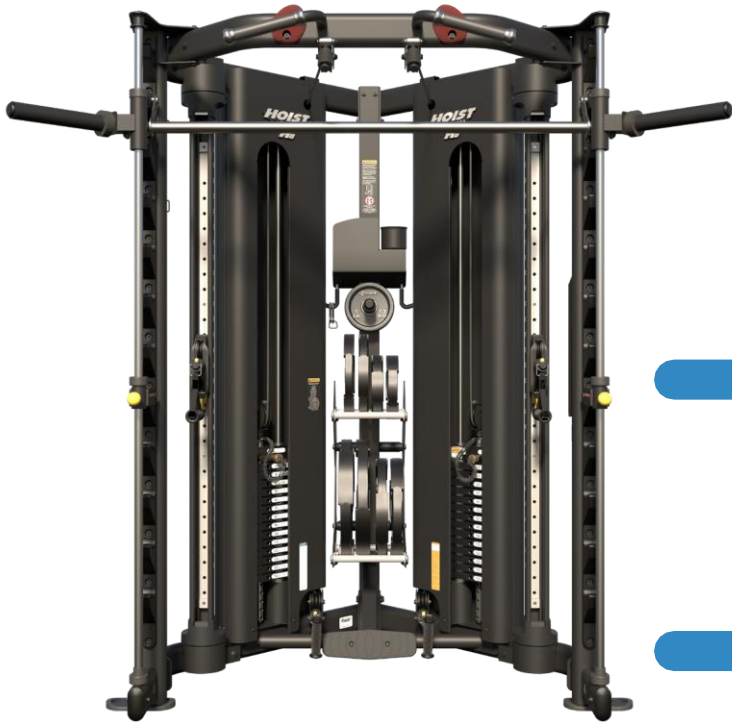
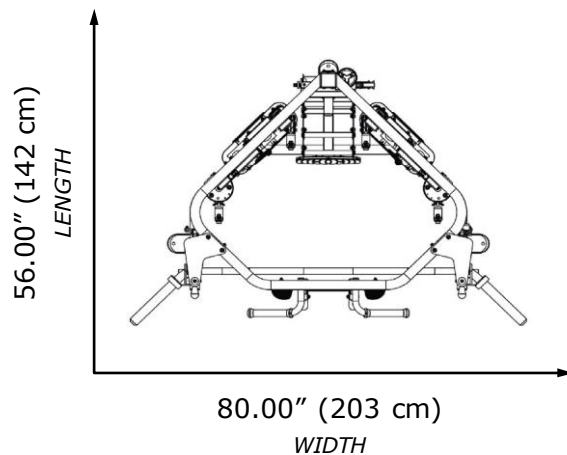

*WEIGHT PLATES SHOWN ARE NOT INCLUDED & SOLD SEPARATELY



Download the HOIST Strength App! (Visit hoistfitness.com/ scan on your smart phone to download a free QR Code Scanner.)

Free HOIST® Strength app provides access to dozens of exercise tutorials, workout plans and fitness training



PRODUCT WEIGHT

903 lbs (410 kg)

1003 lbs (455 kg) with optional 200 lb weight stacks