



INDUSTRIAL PUMPS

A Product From Professionals

Submersible Sludge & Slurry Pumps

ISI Certified Products



Heavy Duty Submersible Sludge & Slurry Pump

(VRIHA Series)



VRIHA series are designed for pumping for raw sewage, sludge and effluent liquids containing large proportion of solid and fibrous matter. These compactly designed pumps are easy to handle and can be installed permanently with the help of auto coupling in the small sump from where sewage is to be pumped or can be used for portable duty. Being submersible, they do not require any pump house.

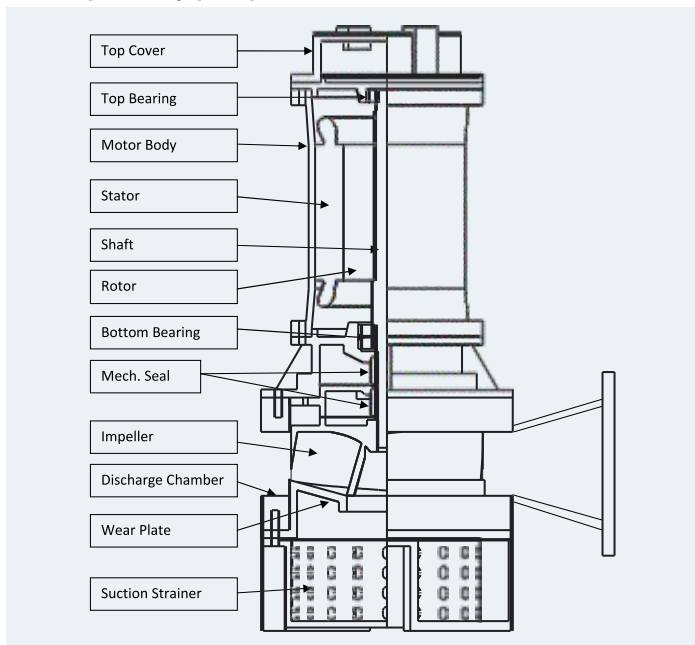

Technical Features

Motor:	Four pole continuous duty squirrel cage submersible type induction motor
Insulation Class:	F
Protection:	IP-68/Thermal Overload / Moisture
Cable:	PVC Insulated Double Sheathed Copper Conductor Flexible

Material of Construction

Motor Body:	C.I./Alu.Alloy/SS
Pump Casing:	C.I IS 210 FG260
Impeller	C.I. IS 210 FG260 / S.S 304 / S.S 316
Shaft:	S.S 410 / S.S 431
Strainer:	S.S 202 / S.S 304
Mech. Seal:	Double Type: TC vs TC(Pump Side)/SIC vs SIC
Bearing:	Deep Groove Ball Bearing (SKP) (Top) Double Row Angular Contact (Bottom)

PERFORMANCE TABLE

Vriha Series (1450 rpm) 50Hz

MODEL	HP	DEL SIZE	SOLID SIZE		HEAD IN METERS											SHUT OFF	
					2	4	6	8	10	12	14	16	18	20	22		
VPPLSL 3.0/4	3	100	40	F L O W	1350	1100	900	800	450	250							15
VPPLSL 5.0/4	5	100	60		1800	1650	1500	1400	1100	800	520	120					17
VPPLSL 7.5/4	7	100	65			2400	2200	2000	1750	1300	900	400					17
VPPLSL 10.0/4	10	100	65			2600	2450	2350	2100	1800	1400	750					18
VPPLSL 15.0/4	15	100	75			3900	2450	3300	3000	2700	2350	1950	1450	900	300		23
VPPLSL 15.0/6	15	150	100				5180	4750	4350	3700	3000	2100	1250	375			19
VPPLSL 20.0/6	20	150	100				6000	5600	5100	4600	4100	3500	3000	2300	1600	850	24
				I N L I N E	6	8	12	16	20	24	28	32	36	40	45		
VPPLSL 20.0/4	20	100	60			2250	2100	1950	1800	1550	1200	550					35
VPPLSL 25.0/4	25	100	60			2650	2580	1460	2280	2100	1850	1550	1200	780	700		39
VPPLSL 30.0/4	30	100	60			2950	2880	2760	2580	2400	2160	1900	1600	1200	1350	700	44
VPPLSL 35.0/4	35	100	60			3250	3150	3000	2850	2700	2450	2250	2000	1720			49
VPPLSL 25.0/6	25	150	100			5430	5100	4350	3500	2250	600						25
VPPLSL 30.0/6	30	150	100			5930	5680	5050	4350	3120	1620						26
VPPLSL 35.0/6	35	150	100		6500	6250	5620	4850	4000	3000	1600					34	
					6	10	15	20	25	30	35	45	50	55	60		
VPPLSL 40.0/6	40	150	100		6700	6100	5300	4400	3200	2000	650					37	
VPPLSL 50.0/6	50	150	100			6450	6000	5200	4400	3500	2400					44	
VPPLSL 60.0/6	60	150	100				6500	6000	5500	5000	4400	3000	2250	1200		60	

Specifications and performance are subject without to change without prior notice. Performance applicable to liquid of specific gravity one & viscosity as of water.

AVAILABLE ON REQUEST • Agitator available on request

APPLICATIONS

- Municipal SEWAGE & SLUDGE & SLURRY pumping removal
- Handling of industrial abrasive and aggressive slurry
- Untreated sewage containing solid particles
- Clogged drainage holes
- Flood control