



HYDRULIC TORQUE WRENCHES



A COMPLETE RANGE OF
HYDRAULIC AND MECHANICAL
TOOLS FOR BOLTING
APPLICATIONS.

SAPSONS INDUSTRIAL EQUIPMENTS PRIVATE LIMITED

INDEX

- 1) **ASQ SERIES SQUARE DRIVE HYDRAULIC WRENCHES.**
- 2) **AHX SERIES LOW CLEARANCE HYDRAULIC WRENCHES.**
- 3) **PUMPS USE WITH HYDRAULIC WRENCHES.**
- 4) **POWER HYDRAULIC NUT SPLITTERS.**
- 5) **POWER FLANGE SPREADERS.**
- 6) **HYDRAULIC VERTICAL LIFTING & SPREADING WEDGE.**
- 7) **CLASSIC MECHANICAL CLICK TORQUE WRENCHES.**
- 8) **HYDRAULIC BOLT TENSIONERS.**

ASQ SERIES SQUARE DRIVE HYDRAULIC WRENCHES

Most Advance Yet Simple Design

✚ ASQ SERIES FEATURES & SPECIFICATIONS



01. **Aircraft Material** - The exclusive light weight uni - body housing.
02. **Balanced Piston Rod Assembly** - Gives load-free piston movement.
03. **Multi-Tooth Drive Segment** - Ensures up to 27 ° torque stroke.
04. **Anti-Back Lash Mechanism** - Hands free operation.
05. **Laser Engraved Torque Chart** - No more referring of catalogue.
06. **Multi-Tooth Ratchet** - Strong Marginal Steel teeth provide strength, accuracy and 27-degree torque stroke.
07. **One Piece Drive Plate** - Strong Marginal Steel provides longer life and increased durability.
08. **Non-Push Drive** - Strong Marginal Steel Enough to withstand Max. Torque.
09. **Direct Housing Reaction** - Allows use of tool without reaction arm.
10. **Steel Reaction Boot** - Protects reaction arm.
11. **Long Reaction Arm** - Allows for reaction on all applications.
12. **Arm Retract Button** - Easy engage and Dis -engagement of Arm.
13. **360 ° x 360 ° Swivel** - Free moment of hose on all applications.
14. **No Drip Quick Connect Couplers** - Assures easy and safe operation.

↳ ASQ SERIES TECHNICAL



Model No.	ASQ 0.75	ASQ 1	ASQ 2	ASQ 3	ASQ 6	ASQ 7	ASQ 11	ASQ- 15	ASQ 20	ASQ 27	ASQ 60
Square Drive	3/4" Non Push Thru	3/4" Non Push Thru	3/4" Non Push Thru	1" Non Push Thru	1.1/2" Non Push Thru	1.1/2" Non Push Thru	1.1/2" Non Push Thru	2.1/2" Non Push Thru	2.1/2" Non Push Thru	2.1/2" Non Push Thru	2.1/2" Non Push Thru
Min. Torque N-m	99	128	188	444	770	1008	1500	2013	2634	3700	7913
(ft/lbs)	77	91	127	330	585	740	1100	1485	1940	2720	5800
Max. Torque N-m	1048	1243	1727	4539	7637	10084	14997	20128	28139	37118	79129
(ft/lbs)	770	914	1270	3330	5600	7400	11000	14845	20625	27200	58000
Output Accuracy	+/-3%	+/-3%	+/-3%	+/-3%	+/-3%	+/-3%	+/-3%	+/-3%	+/-3%	+/-3%	+/-3%
Repeatability	100%	100%	100%	100%	100%	100%	100%	100%	100%	100%	100%
Duty Cycle	100%	100%	100%	100%	100%	100%	100%	100%	100%	100%	100%
Tool Weight Kg / Lbs	1.0 / (2.20)	1.25 / (2.75)	2.50 / (5.80)	4.20 / (9.30)	8.40 / (18.60)	8.90 / (19.60)	13.6 / (30.00)	22.0 / (48.5)	28.5 / (62.7)	32.7 / (72)	60.8 / (133.7)

ASQ SERIES DIMENSIONS

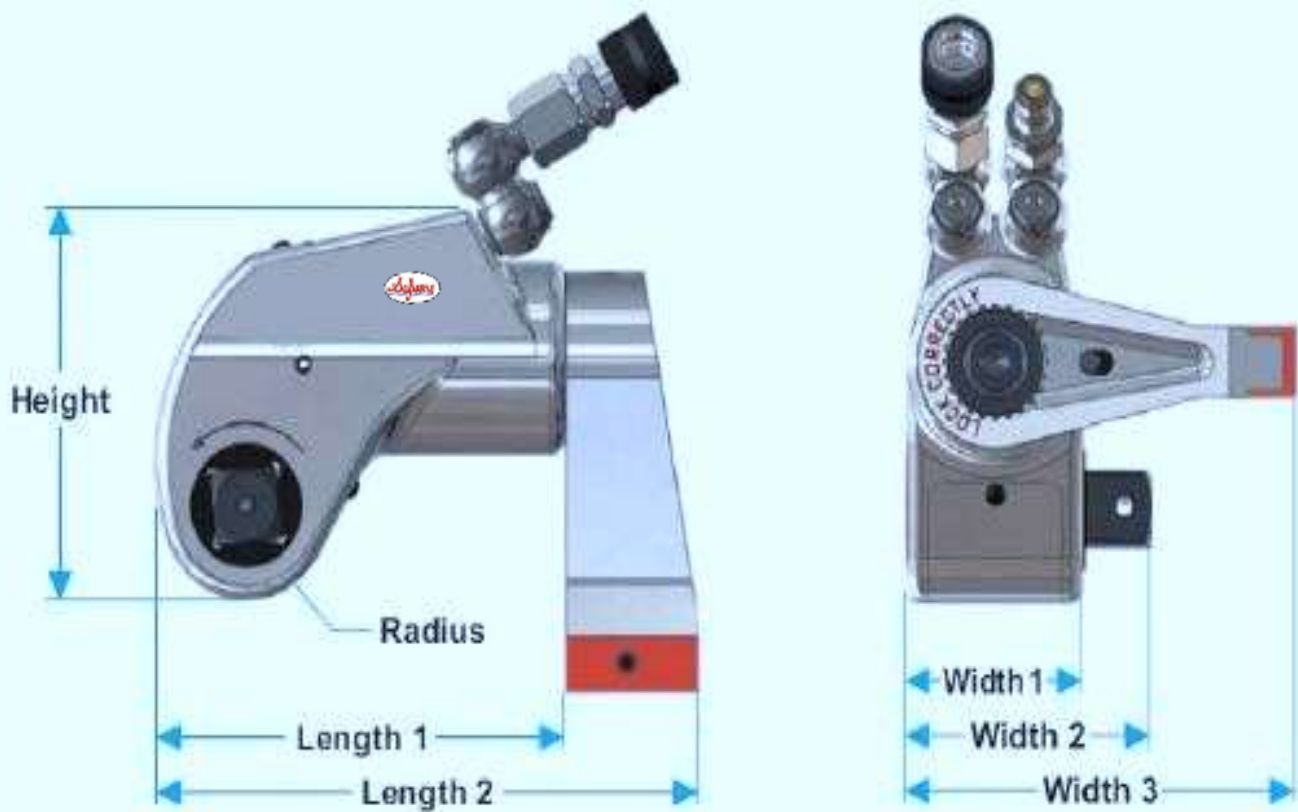

Dimensions

Model No.	ASQ 0.75		ASQ 1		ASQ 2		ASQ 3		ASQ 6		ASQ 7		ASQ 11		ASQ 15		ASQ 20		ASQ 27		ASQ 60	
	MM	Inch	MM	Inch	MM	Inch	MM	Inch	MM	Inch	MM	Inch	MM	Inch	MM	Inch	MM	Inch	MM	Inch	MM	Inch
Height	76	3	88	3.5	105	4.15	135	5.3	163	6.4	182	7.17	198	7.81	232	9.15	237	9.35	259	10.2	292	11.5
Length 1	120	4.75	94	3.7	121	4.76	153	6.02	194	7.62	208	8.2	227	8.95	295	11.6	274	10.8	294	11.6	367	14.5
Length 2	92	3.6	123	4.8	160	6.3	213	8.36	254	10	291	11.5	313	12.3	373	14.7	390	15.3	415	16.4	522	20.6
Radius	19	0.74	20	0.78	25	0.98	33	1.28	41	1.62	45	1.78	50	1.96	59	2.3	58	2.29	63	2.48	79	3.1
Width 1	40	1.57	42	1.65	51	2.01	67	2.64	82	3.22	92	3.61	100	3.94	100	3.93	124	4.88	134	5.28	167	6.58
Width 2	53	2	65	2.55	72	2.81	93	3.67	115	4.55	128	5.05	157	6.18	158	6.2	183	7.19	194	7.65	228	8.9
Width 3	67	2.6	87	3.43	115	4.53	149	5.85	175	6.89	204	8.03	225	8.86	252	9.93	275	10.8	293	11.5	372	14.6

ASQ SERIES ACCESSORIES

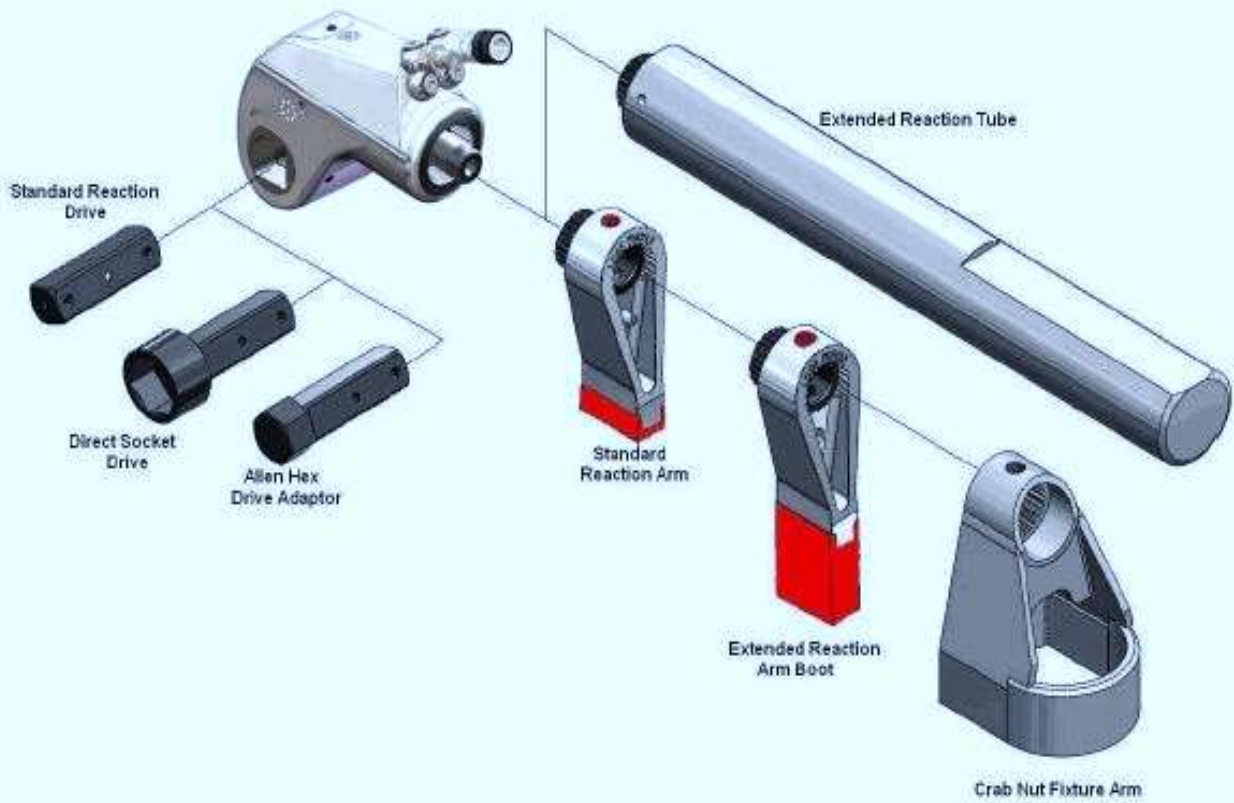

Types of Reaction Arms



In Line Reaction Pad

Tool Model	Length	Height	Width	Ext.
ASQ-2	90.2	42	28.7	21.1
ASQ-3	114.3	54.6	38.6	27.7
ASQ-6	129.5	62.2	47.0	33.8
ASQ-7	158.8	73.7	52.1	42
ASQ-11	174.0	82.8	56.9	49.8
ASQ-15	220.0	98.0	78.8	60.0
ASQ-20	230	105	79.8	76.2
ASQ-27	224.8	110.0	58.4	70
ASQ-60	269.7	140.0	101.6	90

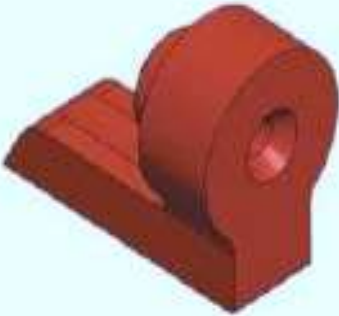

Extended Reaction Tube

Tool Model	Extended Reaction Tube Model	Dia	Length
ASQ-2	AASQ-2-03-ERT	50.8	471.7
ASQ-3	AASQ-3-03-ERT	66.8	603.3
ASQ-6	AASQ-5-03-ERT	76.2	571.5
ASQ-7	AASQ-7-03-ERT	88.9	584.2
ASQ-11	AASQ-11-03-ERT	95.3	637.5
ASQ-15	AASQ-15-03-ERT	101.6	571.5
ASQ-20	AASQ-20-03-ERT	101.6	550
ASQ-27	AASQ-27-03-ERT	127.0	419
ASQ-60	AASQ-60-03-ERT	152.4	355.6



End Cap Protector

Tool Model	End Cap Protector Model
ASQ-0.75	ASQ-0.75- EC
ASQ-1	ASQ-1- EC
ASQ-2	ASQ-2- EC
ASQ-3	ASQ-3- EC
ASQ-6	ASQ-5- EC
ASQ-7	ASQ-7- EC
ASQ-11	ASQ-11- EC
ASQ-15	ASQ-15- EC
ASQ-20	ASQ-20- EC
ASQ-27	ASQ-27- EC
ASQ-60	ASQ-60- EC



EXTENSION BOOT

Part No	Ext	Length	Width
ASQ2-03-EXT1	25.4	38.6	25.4
ASQ2-03-EXT2	50.8		
ASQ2-03-EXT3	76.2		
ASQ3-03-EXT1	25.4	50.8	31.8
ASQ3-03-EXT2	50.8		
ASQ3-03-EXT3	76.2		
ASQ6-03-EXT1	25.4	69.6	50.8
ASQ6-03-EXT2	50.8		
ASQ6-03-EXT3	76.2		
ASQ7-03-EXT1	25.4	69.6	42.7
ASQ7-03-EXT2	50.8		
ASQ7-03-EXT3	76.2		
ASQ11-03-EXT1	25.4	76.2	50.8
ASQ11-03-EXT2	50.8		
ASQ11-03-EXT3	76.2		
ASQ15-03-EXT1	25.4	79.0	59.0
ASQ15-03-EXT2	50.8		
ASQ15-03-EXT3	76.2		
ASQ20-03-EXT1	25.4	105.9	63.5
ASQ20-03-EXT2	50.8		
ASQ20-03-EXT3	76.2		
ASQ27-03-EXT1	25.4	101.6	63.5
ASQ27-03-EXT2	50.8		
ASQ27-03-EXT3	76.2		
ASQ60-03-EXT1	25.4	129.8	89
ASQ60-03-EXT2	50.8		
ASQ60-03-EXT3	76.2		

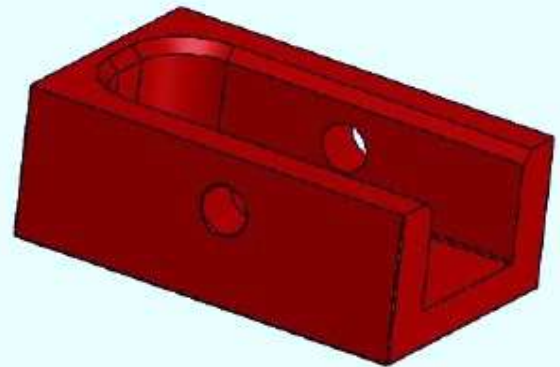

ASQ SERIES TORQUE CONVERSION CHART

For Model ASQ-1 to ASQ-11

PSI	P.S.I./FT./lbs						Bar	Bar/N.M.					
	ASQ1	ASQ2	ASQ3	ASQ6	ASQ7	ASQ11		ASQ1	ASQ2	ASQ3	ASQ6	ASQ7	ASQ11
	ft./lbs	ft./lbs	ft./lbs	ft./lbs	ft./lbs	ft./lbs		N.m	N.m	N.m	N.m	N.m	N.m
1,000	91	127	330	534	740	1,090	68	123	172	447	724	1,003	1,477
1,200	110	152	395	643	888	1,308	82	149	206	535	871	1,203	1,772
1,400	128	178	460	745	1,036	1,526	95	173	241	623	1009	1,404	2,068
1,600	146	203	525	855	1,185	1,745	109	198	275	711	1159	1,606	2,364
1,800	165	229	590	957	1,332	1,962	122	224	310	799	1297	1,805	2,659
2,000	183	255	655	1,067	1,470	2,210	136	248	346	888	1446	1,992	2,995
2,200	201	279	722	1,177	1,617	2,430	150	272	378	978	1595	2,191	3,293
2,400	219	305	789	1,279	1,765	2,652	163	297	413	1069	1733	2,392	3,593
2,600	238	330	856	1,388	1,911	2,873	177	322	447	1160	1881	2,589	3,893
2,800	256	356	923	1,490	2,058	3,095	190	347	482	1251	2019	2,789	4,194
3,000	274	380	990	1,600	2,210	3,340	204	371	515	1341	2168	2,995	4,526
3,200	292	406	1,058	1,710	2,359	3,560	218	396	550	1434	2317	3,196	4,824
3,400	311	432	1,126	1,812	2,505	3,785	231	421	585	1526	2455	3,394	5,129
3,600	329	457	1,194	1,922	2,652	4,005	245	446	619	1618	2604	3,593	5,427
3,800	347	483	1,262	2,024	2,800	4,230	258	470	654	1710	2743	3,794	5,732
4,000	366	510	1,330	2,118	2,960	4,400	272	496	691	1802	2870	4,011	5,962
4,200	384	533	1,397	2,244	3,108	4,620	286	520	722	1893	3041	4,211	6,260
4,400	402	559	1,464	2,346	3,256	4,840	299	545	757	1984	3179	4,412	6,558
4,600	420	584	1,531	2,456	3,405	5,060	313	569	791	2075	3328	4,614	6,856
4,800	439	609	1,598	2,558	3,552	5,280	326	595	825	2165	3466	4,813	7,154
5,000	457	635	1,665	2,667	3,716	5,500	340	619	860	2256	3614	5,035	7,453
5,200	475	660	1,732	2,777	3,865	5,720	354	644	894	2347	3763	5,237	7,751
5,400	494	686	1,799	2,879	4,013	5,940	367	669	930	2438	3901	5,438	8,049
5,600	512	711	1,856	2,989	4,162	6,160	381	694	963	2515	4050	5,640	8,347
5,800	530	737	1,933	3,092	4,311	6,380	394	718	999	2619	4190	5,841	8,645
6,000	548	760	2,000	3,201	4,440	6,620	408	743	1030	2710	4337	6,016	8,970
6,200	567	787	2,065	3,311	4,588	6,838	422	768	1066	2798	4486	6,217	9,265
6,400	585	813	2,130	3,413	4,736	7,060	435	793	1102	2886	4625	6,417	9,566
6,600	603	838	2,195	3,523	4,884	7,280	449	817	1135	2974	4774	6,618	9,864
6,800	622	864	2,260	3,625	5,032	7,500	462	843	1171	3062	4912	6,818	10,163
7,000	640	890	2,325	3,735	5,180	7,710	476	867	1206	3150	5061	7,019	10,447
7,200	658	914	2,398	3,845	5,328	7,927	490	892	1238	3249	5210	7,219	10,741
7,400	676	940	2,461	3,946	5,476	8,147	503	916	1274	3335	5347	7,420	11,039
7,600	695	965	2,529	4,057	5,625	8,368	517	942	1308	3427	5497	7,622	11,339
7,800	713	991	2,597	4,159	5,772	8,588	530	966	1343	3519	5635	7,821	11,637
8,000	731	1,015	2,665	4,269	5,920	8,820	544	991	1375	3611	5784	8,022	11,951
8,200	749	1,041	2,731	4,378	6,068	9,045	558	1015	1411	3701	5932	8,222	12,256
8,400	768	1,067	2,797	4,480	6,216	9,265	571	1041	1446	3790	6070	8,423	12,554
8,600	786	1,092	2,863	4,590	6,365	9,485	585	1065	1480	3879	6219	8,625	12,852
8,800	804	1,118	2,929	4,692	6,512	9,705	598	1089	1515	3969	6358	8,824	13,150
9,000	823	1,145	2,995	4,802	6,660	9,930	612	1115	1551	4058	6507	9,024	13,455
9,200	841	1,168	3,062	4,912	6,808	10,148	626	1140	1583	4149	6656	9,225	13,751
9,400	859	1,194	3,129	5,014	6,956	10,368	639	1164	1618	4240	6794	9,425	14,049
9,600	877	1,219	3,196	5,124	7,105	10,588	653	1188	1652	4331	6943	9,627	14,347
9,800	896	1,245	3,263	5,226	7,252	10,810	666	1214	1687	4421	7081	9,826	14,648
10,000	914	1,270	3,330	5,340	7,400	11,010	680	1238	1721	4512	7236	10,027	14,919

✚ ASQ SERIES TORQUE CONVERSION CHART

For Model ASQ-15 to ASQ-60

PSI	P.S.I./FT./lbs				Bar	Bar/N.M.			
	ASQ15 ft./lbs	ASQ20 ft./lbs	ASQ27 ft./lbs	ASQ60 ft./lbs		ASQ15 N.m.	ASQ20 N.m.	ASQ27 N.m.	ASQ60 N.m.
1,000	1,475	1940	2,720	5,943	68	1999	2629	3,686	8,053
1,200	1,770	2328	3,264	7,132	82	2398	3154	4,423	9,664
1,400	2,065	2716	3,808	8,320	95	2798	3680	5,160	11,274
1,600	2,360	3104	4,352	9,509	109	3198	4206	5,897	12,885
1,800	2,655	3492	4,896	10,697	122	3598	4732	6,634	14,494
2,000	2,950	3880	5,440	11,662	136	3997	5190	7,371	15,802
2,200	3,245	4213	5,984	12,828	150	4397	5709	8,108	17,382
2,400	3,540	4596	6,528	13,994	163	4797	6228	8,845	18,962
2,600	3,835	4979	7,072	15,161	177	5196	6747	9,583	20,543
2,800	4,130	5362	7,616	16,327	190	5596	7266	10,320	22,123
3,000	4,425	5920	8,160	17,387	204	5996	8022	11,057	23,559
3,200	4,720	6315	8,704	18,546	218	6396	8557	11,794	25,130
3,400	5,015	6709	9,248	19,705	231	6795	9091	12,531	26,700
3,600	5,310	7,104	9,792	20,864	245	7195	9626	13,268	28,271
3,800	5,605	7,499	10,336	22,024	258	7595	10161	14,005	29,843
4,000	5,900	7,985	10,880	23,286	272	7995	10820	14,742	31,553
4,200	6,195	8,384	11,424	24,450	286	8394	11360	15,480	33,130
4,400	6,490	8,784	11,968	25,615	299	8794	11902	16,217	34,708
4,600	6,785	9,183	12,512	26,779	313	9194	12443	16,954	36,286
4,800	7,080	9,582	13,056	27,943	326	9593	12984	17,691	37,863
5,000	7,376	10,120	13,600	29,322	340	9994	13713	18,428	39,731
5,200	7,671	10,525	14,144	30,495	354	10394	14261	19,165	41,321
5,400	7,966	10,930	14,688	31,668	367	10794	14810	19,902	42,910
5,600	8,261	11,334	15,232	32,841	381	11194	15358	20,639	44,500
5,800	8,556	11,739	15,776	34,014	394	11593	15906	21,376	46,089
6,000	8,851	12,215	16,320	34,696	408	11993	16551	22,114	47,013
6,200	9,146	12,622	16,864	36,135	422	12393	17103	22,851	48,963
6,400	9,441	13,029	17,408	37,300	435	12793	17654	23,588	50,542
6,600	9,736	13,437	17,952	38,466	449	13192	18207	24,325	52,121
6,800	10,031	13,844	18,496	39,632	462	13592	18759	25,062	53,701
7,000	10,326	14,330	19,040	40,914	476	13992	19417	25,799	55,438
7,200	10,621	14,739	19,584	42,083	490	14391	19971	26,536	57,022
7,400	10,916	15,149	20,128	43,252	503	14791	20527	27,273	58,606
7,600	11,211	15,558	20,672	44,421	517	15191	21081	28,011	60,190
7,800	11,506	15,968	21,216	45,590	530	15591	21637	28,748	61,774
8,000	11,801	16,500	21,760	46,859	544	15990	22358	29,485	63,494
8,200	12,096	16,913	22,304	48,030	558	16390	22917	30,222	65,081
8,400	12,391	17,325	22,848	49,202	571	16790	23475	30,959	66,669
8,600	12,686	17,738	23,392	50,373	585	17190	24035	31,696	68,255
8,800	12,981	18,150	23,936	51,545	598	17589	24593	32,433	69,843
9,000	13,276	18,625	24,480	52,799	612	17989	25237	33,170	71,543
9,200	13,571	19,039	25,024	53,972	626	18389	25798	33,908	73,132
9,400	13,866	19,453	25,568	55,146	639	18788	26359	34,645	74,723
9,600	14,161	19,867	26,112	56,319	653	19188	26920	35,382	76,312
9,800	14,456	20,281	26,656	57,492	666	19588	27481	36,119	77,902
10,000	14,751	20,625	27,200	59,401	680	19988	27947	36,856	80,488

AHX SERIES LOW CLEARANCE HYDRAULIC WRENCHES

Most Unique Yet Innovative Design

✚ AHX SERIES FEATURES & SPECIFICATIONS



01. **Unique Design Cylinder** - Fit both the cylinder and link in confined areas.
02. **Auto Engagement Rod** - Automatically engages link on the first stroke.
03. **Never-Lock Drive Segment** - Ensures tool will NEVER lock on.
04. **Multi-Tooth Ratchet** - Allows for 27-degree torque stroke accuracy.
05. **One Piece Drive Plate** - Robust alloy provides for small nose radius.
06. **Single Link Pin** - Link to cylinder engagement, no tools required.
07. **In-Line Reaction Pad** - Assures torsion free reaction every time.
08. **Steel Alignment Pin** - Assures equal load displacement between side plates.
09. **Innovative Design** - Cylinder and link width are equal for tight fits.
10. **360° x 360° Swivel** - Allows hose to be cleared on all applications.
11. **Curved Slider** - Prevents wear of piston and drive plate and reduces cost of repairs.
12. **Nose Radius** - Tight nose radius allows this tool to fit on limited access applications.
13. **High Strength Construction** - Both cylinder and cassette are manufactured from high strength, high grade aircraft alloy.

✦ AHX SERIES TECHNICAL



Technical Data

Model No.		AHX-0.75	AHX-1	AHX-1.5	AHX-2	AHX-4	AHX-8	AHX-16	AHX-32	AHX-45
Tool Hex mm / Inch	From	13 1/2"	13 1/2"	19 3/4"	19 3/4"	25 1"	50 1.7/8"	65 2.5/8"	80 3.1/8"	80 3.1/8"
	To	41 1.5/8"	41 5/8"	46 1.5/8"	60 2.3/8"	80 3.1/8"	105 4"	115 4.5/8"	155 6.1/8"	155 6.1/8"
Min Torque N-m (ft/lbs)		55.58(41)	61.0(45)	135.5(100)	260(192)	540 (395)	1125 (830)	2115 (1560)	4365(3220)	6600(4865)
MAX Torque N-m (ft/lbs)		665 (490)	760 (560)	1350 (995)	2614(1928)	5355(3950)	11700(8630)	22506(16600)	48335(35650)	65595(47380)
Output Accuracy		+/-3%	+/-3%	+/-3%	+/-3%	+/-3%	+/-3%	+/-3%	+/-3%	+/-3%
Repeatability		100%	100%	100%	100%	100%	100%	100%	100%	100%
Duty Cycle		100%	100%	100%	100%	100%	100%	100%	100%	100%
Corrosion Protection		Standard								
Cylinder Weight Kg / Lbs		0.38/ (0.84)	0.50/ (1.1)	0.55/ (1.2)	1.59 / (3.50)	2.73 / (6.00)	5.32 / (11.70)	7.27 / (16.00)	11.82 / (26.00)	13.7 / (30.2)
Link Weight Kg / Lbs	From	0.47/ (1)	0.50/ (1)	0.60/ (1.3)	1.09 / (2.40)	2.45 / (5.40)	5.41 / (11.90)	9.55 / (21.00)	13.18 / (29.00)	13.18 / (29.00)
	To	0.47/ (1)	0.50/ (1)	0.90/ (2.0)	1.59 / (3.50)	3.45 / (7.60)	6.59 / (14.50)	12.73 / (2.00)	17.95 / (39.50)	17.95 / (39.50)

AHX SERIES DIMENSIONS

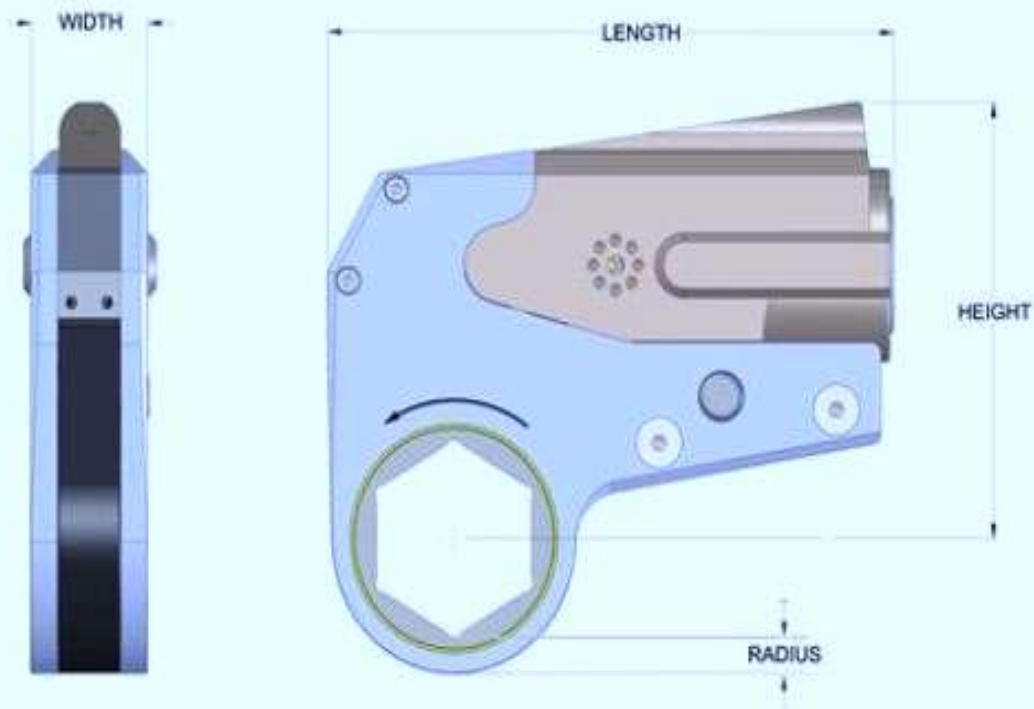

Dimensions

Model No.	AHX-0.75		AHX-1		AHX-1.5		AHX-2		AHX-4		AHX-8		AHX-16		AHX-32		AHX-45	
	MM	Inch	MM	Inch	MM	Inch	MM	Inch	MM	Inch	MM	Inch	MM	Inch	MM	Inch	MM	Inch
Length	108	4.25	111	4.37	107	4.2	167	6.57	203.2	8	253	9.96	330	13	390	15.35	450	17.71
Height	82.6	3.25	82.6	3.25	87	3.4	103	4.05	144	5.66	179.5	7.06	193.8	7.63	278	10.94	278	10.94
Width	18	0.7	19.8	0.78	28	1.1	38	1.49	50.7	1.99	59.5	2.34	65	2.56	84	3.3	84	3.3
Radius	5.8	0.23	5.8	0.23	7.5	0.3	9.3	0.36	11.85	0.46	13.9	0.54	16.8	0.66	23.75	0.94	23.75	0.94

✦ AHX SERIES ACCESSORIES

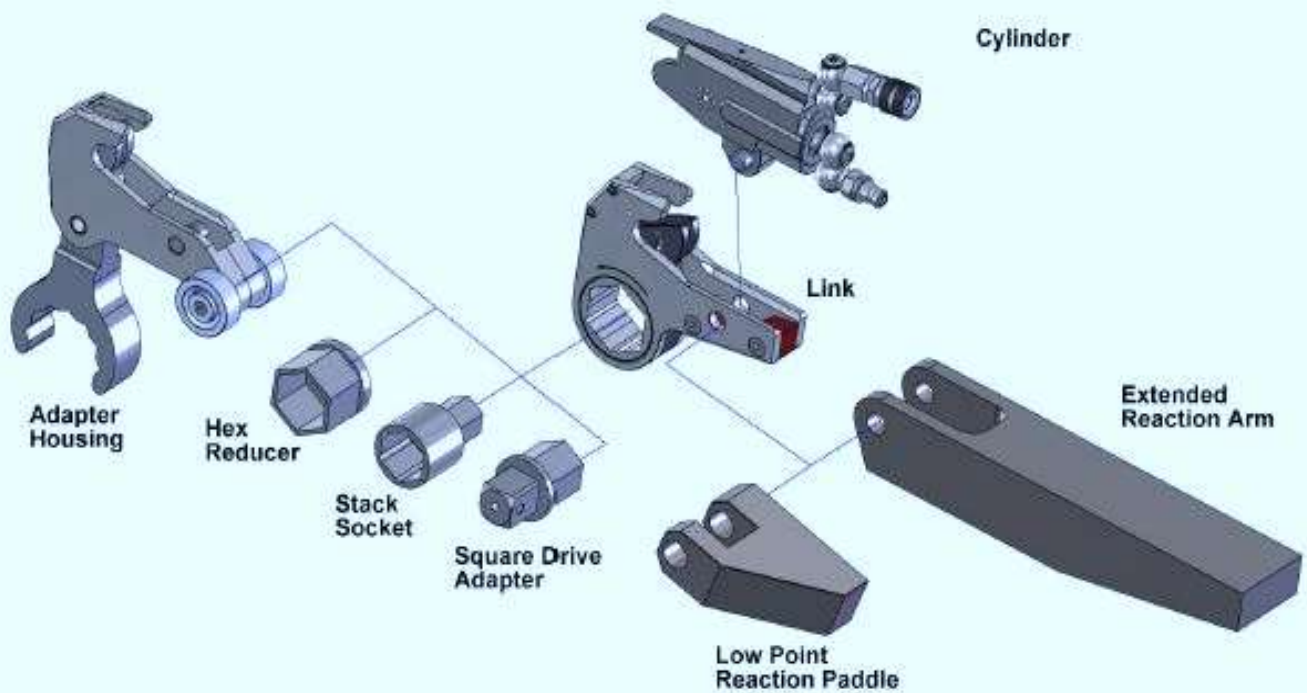

Low Point Reaction Arm

Tool Model	Low Point Reaction Arm Model	Length	Width	Height 1	Height 2
AHX-1	AHX-1-RP	69.3	16.5	23	49.8
AHX-2	AHX-2-RP	110.5	26.2	37.8	82.8
AHX-4	AHX-4-RP	143.5	31.2	51.3	107.4
AHX-8	AHX-8-RP	181.6	45.2	64.3	136
AHX-16	AHX-16-RP	230	63.8	77.2	161.5
AHX-32	AHX-32-RP	284.5	82.8	100.3	210.8
AHX-45	AHX-45-RP	30.5	82.8	100.3	210.8

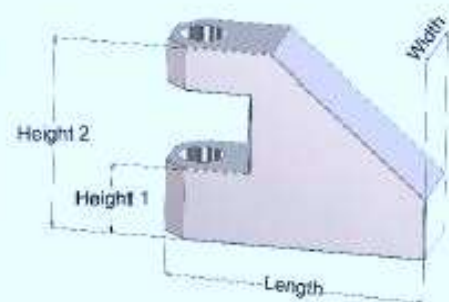

Extended Reaction Arm

Tool Model	Extended Reaction Arm Model	Length	Height 1	Width
AHX-1	AHX-1-EXT	343	31.8	31.8
AHX-2	AHX-2-EXT	503	39	48.3
AHX-4	AHX-4-EXT	515.4	52	61.0
AHX-8	AHX-8-EXT	529.6	64.0	77.0
AHX-16	AHX-16-EXT	546	77.2	92.7
AHX-32	AHX-32-EXT	566	100.3	114.8
AHX-45	AHX-45-EXT	566	100.3	114.8

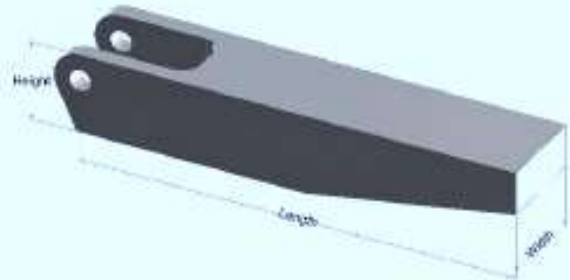

Hex To Square Drive Adaptor

Tool Model	Hex To Square Drive Adaptor Model
AHX-1	AHS1
AHX-2	AHS 2
AHX-4	AHS 4
AHX-8	AHS 8
AHX-16	AHS 16
AHX-32	AHS 32
AHX-45	AHS 45

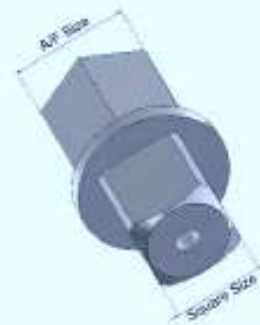

Hex Reducer

Tool Model	Hex Reducer Model
AHX-1	HR-1-##
AHX-2	HR-2-##
AHX-4	HR-4-##
AHX-8	HR-8-##
AHX-16	HR-16-##
AHX-32	HR-32-##
AHX-45	HR-45-##

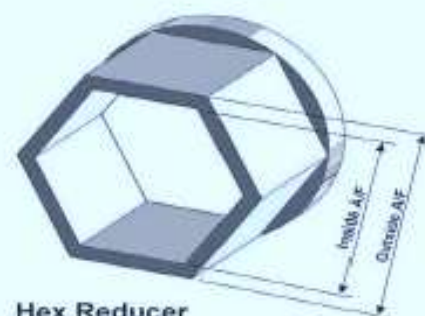

Hex Reducer

AHX SERIES TORQUE CONVERSION CHART

For Model AHX-1 to AHX-45

AHX Series Torque Conversion Chart

Bar /N.m												
Model	AHX-1		AHX-2		AHX-4	AHX-8	AHX-18		AHX-32		AHX-46	
Hex Size	1/2" to 1 1/8"	1 3/16" to 1 5/8"	3/4" to 1-13/16"	1-7/8" to 2-3/8"	All Hex Sizes	All Hex Sizes	2-5/8" to 3-15/16"	4" to 4-5/8"	2-7/16" to 4-5/8"	4-11/16" to 6-1/2"	2-7/16" to 4-5/8"	4-11/16" to 6-1/2"
	17 to 27 MM	30 to 41 MM	19 to 48MM	47 to 80MM	All Hex Sizes	All Hex Sizes	65 to 100MM	105 to 115MM	80 to 115MM	115 to 155MM	80 to 115MM	115 to 165MM
Bar	N.m	N.m	N.m	N.m	N.m	N.m	N.m	N.m	N.m	N.m	N.m	N.m
68	67	90	280	285	535	1,125	2,115	2,250	4,324	5,018	6,351	6,577
82	78	104	312	342	644	1,357	2,535	2,700	5,280	6,019	7,341	7,534
95	80	118	365	399	752	1,590	2,955	3,150	6,185	7,022	8,330	8,591
109	102	132	418	455	854	1,822	3,382	3,600	7,130	8,025	9,320	10,347
122	114	148	489	512	982	2,055	3,802	4,051	8,088	9,028	10,308	11,804
136	128	160	522	589	1,071	2,288	4,228	4,501	8,988	10,031	11,303	12,858
150	138	178	572	628	1,179	2,528	4,850	4,951	9,871	11,035	12,444	14,152
163	148	190	625	683	1,288	2,768	5,070	5,401	10,747	12,038	13,588	15,447
177	160	208	678	740	1,389	3,008	5,480	5,851	11,823	13,041	14,727	16,742
190	171	220	728	797	1,498	3,248	5,817	6,301	12,488	14,044	15,888	18,038
204	183	235	784	868	1,608	3,488	6,337	6,751	13,374	15,047	17,010	19,331
218	198	252	832	923	1,715	3,782	6,784	7,228	14,250	16,050	18,186	20,808
231	208	268	885	981	1,823	4,034	7,185	7,651	15,128	17,053	19,380	21,885
245	221	285	937	1,038	1,925	4,307	7,805	8,101	16,002	18,057	20,584	23,182
258	233	300	990	1,097	2,033	4,579	8,332	8,551	16,877	19,060	21,748	24,438
272	248	317	1,045	1,159	2,142	4,853	8,452	9,015	17,895	20,063	22,938	25,718
286	259	333	1,093	1,212	2,250	5,093	8,879	9,488	18,790	21,068	24,078	26,995
299	271	348	1,145	1,270	2,359	5,275	9,299	9,918	19,885	22,068	25,218	28,275
313	284	368	1,197	1,328	2,460	5,485	9,720	10,388	20,979	23,072	26,358	29,555
326	298	381	1,250	1,385	2,569	5,698	10,147	10,818	21,474	24,075	27,488	30,834
340	308	398	1,307	1,450	2,677	5,908	10,567	11,333	22,387	25,079	28,644	32,114
354	320	412	1,353	1,507	2,786	6,152	10,987	11,788	23,288	26,082	29,738	33,398
367	331	428	1,408	1,566	2,894	6,398	11,414	12,240	24,185	27,085	30,843	34,682
381	344	442	1,457	1,624	2,999	6,640	11,834	12,692	25,084	28,088	32,092	35,965
394	355	458	1,510	1,682	3,104	6,884	12,261	13,147	25,982	29,091	33,242	37,248
408	368	472	1,567	1,742	3,213	7,128	12,682	13,602	26,881	30,094	34,394	38,533
422	380	488	1,613	1,799	3,321	7,334	13,102	14,148	27,718	31,097	35,508	39,825
435	392	503	1,668	1,857	3,430	7,540	13,522	14,604	28,577	32,101	36,617	41,117
449	404	520	1,718	1,914	3,531	7,747	13,948	15,081	29,435	33,104	37,729	42,409
462	418	535	1,769	1,972	3,640	7,953	14,388	15,518	30,480	34,107	38,841	43,700
476	428	551	1,829	2,033	3,748	8,181	14,799	15,983	31,153	35,110	39,958	44,992
490	441	567	1,873	2,089	3,857	8,388	15,217	16,342	32,044	36,113	41,113	46,284
503	452	582	1,926	2,146	3,965	8,611	15,637	16,798	32,834	37,116	42,289	47,578
517	465	598	1,979	2,204	4,067	8,837	16,064	17,250	33,825	38,119	43,425	48,868
530	477	613	2,029	2,262	4,175	9,062	16,494	17,830	34,718	39,123	44,582	50,180
544	489	628	2,080	2,325	4,284	9,289	16,911	18,314	35,805	40,128	45,738	51,452
558	502	644	2,134	2,379	4,392	9,520	17,331	18,772	36,485	41,129	46,852	52,702
571	513	659	2,187	2,437	4,501	9,754	17,752	19,231	37,388	42,132	47,984	53,952
585	525	674	2,238	2,494	4,602	9,985	18,172	19,687	38,277	43,135	49,075	55,201
598	538	689	2,291	2,553	4,711	10,219	18,599	20,148	39,187	44,138	50,187	56,451
612	548	705	2,352	2,615	4,819	10,452	19,019	20,381	40,068	45,141	51,298	57,701
626	561	720	2,394	2,669	4,928	10,701	19,448	20,814	40,947	46,145	52,470	58,907
639	572	735	2,447	2,729	5,029	10,951	19,898	21,287	41,837	47,148	53,644	60,312
653	585	751	2,498	2,784	5,138	11,200	20,287	21,718	42,728	48,151	54,818	61,817
666	598	765	2,551	2,843	5,248	11,448	20,714	22,171	43,615	49,154	55,992	63,223
680	608	781	2,614	2,908	5,355	11,699	21,141	22,503	44,504	50,157	57,188	64,228

AHX SERIES TORQUE CONVERSION CHART

For Model AHX-1 to AHX-45

AHX Series Torque Conversion Chart												
P.SI/FT./lbs												
Model	AHX-1		AHX-2		AHX-4	AHX-8	AHX-16		AHX-32		AHX-45	
Hex Sizes	1/2" to 1 1/8"	1 3/16" to 1 5/8"	3/4" to 1-13/16"	1-7/8" to 2-3/8"	All Hex Sizes	All Hex Sizes	2-5/8" to 3-15/16"	4" to 4-5/8"	2-7/16" to 4-5/8"	4-11/16" to 6-1/2"	2-7/16" to 4-5/8"	4-11/16" to 6-1/2"
P#1	Ft/lbs	Ft/lbs	Ft / lbs	Ft / lbs	Ft / lbs	Ft / lbs	Ft / lbs	Ft / lbs	Ft / lbs	Ft / lbs	Ft / lbs	Ft / lbs
1,000	49	66	192	210	395	830	1,560	1,660	3,190	3,700	4,685	4,852
1,200	58	77	230	252	475	1,001	1,870	1,992	3,880	4,440	5,415	5,779
1,400	66	87	269	294	555	1,173	2,180	2,324	4,570	5,180	6,145	6,706
1,600	75	97	307	336	630	1,344	2,495	2,656	5,260	5,920	6,875	7,333
1,800	84	108	346	378	710	1,516	2,805	2,988	5,950	6,660	7,605	8,060
2,000	93	118	385	420	790	1,688	3,120	3,320	6,636	7,400	8,338	8,885
2,200	102	130	422	462	870	1,865	3,430	3,652	7,282	8,140	9,180	10,440
2,400	110	140	461	504	950	2,042	3,740	3,984	7,928	8,880	10,022	11,395
2,600	118	152	500	546	1,025	2,219	4,050	4,316	8,574	9,620	10,864	12,350
2,800	126	162	537	588	1,105	2,396	4,365	4,648	9,220	10,360	11,706	13,305
3,000	135	173	578	640	1,185	2,574	4,675	4,980	9,866	11,100	12,548	14,260
3,200	145	186	614	691	1,265	2,775	4,990	5,360	10,512	11,840	13,422	15,202
3,400	153	198	653	724	1,345	2,976	5,300	5,644	11,158	12,580	14,296	16,144
3,600	163	210	691	766	1,420	3,177	5,610	5,976	11,804	13,320	15,170	17,086
3,800	172	221	730	809	1,500	3,378	5,925	6,308	12,450	14,060	16,044	18,028
4,000	181	234	771	855	1,580	3,580	6,235	6,650	13,201	14,800	16,921	18,970
4,200	191	246	806	894	1,660	3,735	6,550	6,983	13,861	15,540	17,762	19,914
4,400	200	257	845	937	1,740	3,891	6,860	7,315	14,521	16,280	18,603	20,858
4,600	209	270	883	980	1,815	4,046	7,170	7,648	15,181	17,020	19,444	21,802
4,800	218	281	922	1,022	1,895	4,202	7,485	7,980	15,841	17,760	20,285	22,746
5,000	227	292	964	1,070	1,975	4,358	7,795	8,360	16,500	18,500	21,130	23,690
5,200	236	304	998	1,112	2,055	4,538	8,105	8,694	17,163	19,240	21,978	24,637
5,400	244	314	1,037	1,155	2,135	4,718	8,420	9,029	17,826	19,980	22,826	25,584
5,600	254	326	1,075	1,198	2,210	4,898	8,730	9,363	18,489	20,720	23,674	26,531
5,800	262	336	1,114	1,241	2,290	5,078	9,045	9,698	19,152	21,460	24,522	27,478
6,000	271	348	1,156	1,285	2,370	5,258	9,355	10,100	19,815	22,200	25,372	28,425
6,200	280	360	1,190	1,327	2,450	5,410	9,665	10,437	20,448	22,940	26,192	29,378
6,400	289	371	1,229	1,370	2,530	5,562	9,975	10,773	21,081	23,680	27,012	30,331
6,600	298	384	1,267	1,412	2,605	5,715	10,290	11,110	21,714	24,420	27,832	31,284
6,800	307	395	1,305	1,455	2,685	5,867	10,600	11,447	22,470	25,160	28,652	32,237
7,000	316	406	1,345	1,500	2,765	6,020	10,915	11,720	22,981	25,900	29,475	33,190
7,200	325	418	1,382	1,541	2,845	6,186	11,225	12,055	23,638	26,640	30,328	34,143
7,400	333	429	1,421	1,583	2,925	6,352	11,535	12,390	24,295	27,380	31,181	35,096
7,600	343	441	1,460	1,626	3,000	6,519	11,850	12,725	24,952	28,120	32,034	36,049
7,800	352	452	1,497	1,669	3,080	6,685	12,160	13,005	25,609	28,860	32,887	37,002
8,000	361	463	1,542	1,715	3,160	6,852	12,475	13,510	26,265	29,600	33,740	37,955
8,200	370	475	1,574	1,755	3,240	7,023	12,785	13,848	26,922	30,340	34,562	38,877
8,400	378	486	1,613	1,798	3,320	7,195	13,095	14,186	27,579	31,080	35,382	39,799
8,600	387	497	1,651	1,840	3,395	7,366	13,405	14,523	28,236	31,820	36,202	40,721
8,800	395	508	1,690	1,883	3,475	7,538	13,720	14,861	28,893	32,560	37,022	41,643
9,000	404	520	1,735	1,929	3,555	7,710	14,030	15,020	29,550	33,300	37,840	42,565
9,200	414	531	1,766	1,969	3,635	7,894	14,345	15,354	30,206	34,040	38,706	43,528
9,400	422	542	1,805	2,011	3,710	8,078	14,655	15,688	30,862	34,780	39,572	44,454
9,600	431	554	1,843	2,054	3,790	8,262	14,965	16,021	31,518	35,520	40,438	45,454
9,800	440	564	1,882	2,097	3,870	8,446	15,280	16,355	32,174	36,260	41,304	46,417
10,000	448	576	1,928	2,145	3,950	8,630	15,595	16,600	32,830	37,000	42,170	47,380

+ AHX SERIES HEX LINK PART NUMBER

AHX-1 Link Number	Hex Size	AHX-2 Link Number	Hex Size	AHX-4 Link Number	Hex Size	AHX-6 Link Number	Hex Size	AHX-8 Link Number	Hex Size	AHX-16 Link Number	Hex Size	AHX-32 Link Number	Hex Size
AHX-1RL008	1/2"	AHX-2RL012	3/4"	AHX-4RL100	1"	AHX-6RL114	1.7/8"	AHX-8RL210	2.5/8"	AHX-16RL302	3.1/8"	AHX-32RL302	3.1/8"
AHX-1RL009	9/16"	AHX-2RL013	13/16"	AHX-4RL101	1.1/16"	AHX-6RL115	1.15/16"	AHX-8RL211	2.11/16"	AHX-16RL303	3.3/16"	AHX-32RL303	3.3/16"
AHX-1RL010	5/8"	AHX-2RL014	7/8"	AHX-4RL102	1.1/8"	AHX-6RL200	2"	AHX-8RL212	2.3/8"	AHX-16RL304	3.1/4"	AHX-32RL304	3.1/4"
AHX-1RL011	11/16"	AHX-2RL015	15/16"	AHX-4RL103	1.3/16"	AHX-6RL201	2.1/16"	AHX-8RL213	2.13/16"	AHX-16RL305	3.5/16"	AHX-32RL305	3.5/16"
AHX-1RL012	3/4"	AHX-2RL100	1"	AHX-4RL104	1.1/4"	AHX-6RL202	2.1/8"	AHX-8RL214	2.7/8"	AHX-16RL306	3.3/8"	AHX-32RL306	3.3/8"
AHX-1RL013	13/16"	AHX-2RL101	1.1/8"	AHX-4RL105	1.5/16"	AHX-6RL203	2.5/16"	AHX-8RL215	2.15/16"	AHX-16RL307	3.7/16"	AHX-32RL307	3.7/16"
AHX-1RL014	7/8"	AHX-2RL102	1.1/8"	AHX-4RL106	1.3/8"	AHX-6RL204	2.1/4"	AHX-8RL300	3"	AHX-16RL308	3.1/2"	AHX-32RL308	3.1/2"
AHX-1RL015	15/16"	AHX-2RL103	1.3/8"	AHX-4RL107	1.7/16"	AHX-6RL205	2.5/16"	AHX-8RL301	3.1/8"	AHX-16RL309	3.9/16"	AHX-32RL309	3.9/16"
AHX-1RL100	1"	AHX-2RL104	1.1/4"	AHX-4RL108	1.1/2"	AHX-6RL206	2.3/8"	AHX-8RL302	3.1/8"	AHX-16RL310	3.5/8"	AHX-32RL310	3.5/8"
AHX-1RL101	1.1/16"	AHX-2RL105	1.5/16"	AHX-4RL109	1.9/16"	AHX-6RL207	2.7/16"	AHX-8RL303	3.5/16"	AHX-16RL311	3.11/16"	AHX-32RL311	3.11/16"
AHX-1RL102	1.1/8"	AHX-2RL106	1.3/8"	AHX-4RL110	1.5/8"	AHX-6RL208	2.1/2"	AHX-8RL304	3.1/4"	AHX-16RL312	3.3/4"	AHX-32RL312	3.3/4"
AHX-1RL103	1.3/16"	AHX-2RL107	1.7/16"	AHX-4RL111	1.11/16"	AHX-6RL209	2.9/16"	AHX-8RL305	3.5/16"	AHX-16RL313	3.13/16"	AHX-32RL313	3.13/16"
AHX-1RL104	1.1/4"	AHX-2RL108	1.1/2"	AHX-4RL112	1.3/4"	AHX-6RL210	2.5/8"	AHX-8RL306	3.3/8"	AHX-16RL314	3.7/8"	AHX-32RL314	3.7/8"
AHX-1RL105	1.5/16"	AHX-2RL109	1.9/16"	AHX-4RL113	1.13/16"	AHX-6RL211	2.11/16"	AHX-8RL307	3.7/16"	AHX-16RL315	3.15/16"	AHX-32RL315	3.15/16"
AHX-1RL106	1.3/8"	AHX-2RL110	1.5/8"	AHX-4RL114	1.7/8"	AHX-6RL212	2.3/4"	AHX-8RL308	3.1/2"	AHX-16RL400	4"	AHX-32RL400	4"
AHX-1RL107	1.7/16"	AHX-2RL111	1.11/16"	AHX-4RL115	1.15/16"	AHX-6RL213	2.13/16"	AHX-8RL309	3.9/16"	AHX-16RL401	4.1/16"	AHX-32RL401	4.1/16"
AHX-1RL108	1.1/2"	AHX-2RL112	1.3/4"	AHX-4RL200	2"	AHX-6RL214	2.7/8"	AHX-8RL310	3.5/8"	AHX-16RL402	4.1/8"	AHX-32RL402	4.1/8"
AHX-1RL109	1.9/16"	AHX-2RL113	1.13/16"	AHX-4RL201	2.1/16"	AHX-6RL215	2.15/16"	AHX-8RL311	3.11/16"	AHX-16RL403	4.3/16"	AHX-32RL403	4.3/16"
AHX-1RL110	1.5/8"	AHX-2RL114	1.7/8"	AHX-4RL202	2.1/8"	AHX-6RL300	3"	AHX-8RL312	3.3/8"	AHX-16RL404	4.1/4"	AHX-32RL404	4.1/4"
		AHX-2RL115	1.15/16"	AHX-4RL203	2.3/16"	AHX-6RL301	3.1/8"	AHX-8RL313	3.13/16"	AHX-16RL405	4.5/16"	AHX-32RL405	4.5/16"
		AHX-2RL200	2"	AHX-4RL204	2.1/4"	AHX-6RL302	3.1/8"	AHX-8RL314	3.7/8"	AHX-16RL406	4.3/8"	AHX-32RL406	4.3/8"
		AHX-2RL201	2.1/8"	AHX-4RL205	2.5/16"	AHX-6RL303	3.3/16"	AHX-8RL315	3.15/16"	AHX-16RL407	4.7/16"	AHX-32RL407	4.7/16"
		AHX-2RL202	2.1/8"	AHX-4RL206	2.3/8"	AHX-6RL304	3.1/8"	AHX-8RL400	4"	AHX-16RL408	4.1/2"	AHX-32RL408	4.1/2"
		AHX-2RL203	2.3/8"	AHX-4RL207	2.7/16"	AHX-6RL305	3.5/16"	AHX-8RL401	4.1/8"	AHX-16RL409	4.9/16"	AHX-32RL409	4.9/16"
		AHX-2RL204	2.1/4"	AHX-4RL208	2.1/2"	AHX-6RL306	3.3/8"	AHX-8RL402	4.1/8"	AHX-16RL410	4.5/8"	AHX-32RL410	4.5/8"
		AHX-2RL205	2.5/8"	AHX-4RL209	2.9/16"	AHX-6RL307	3.7/16"	AHX-8RL403	4.3/16"	AHX-16RL411	4.11/16"	AHX-32RL411	4.11/16"
		AHX-2RL206	2.3/8"	AHX-4RL210	2.5/8"	AHX-6RL308	3.1/2"	AHX-8RL404	4.1/4"	AHX-16RL412	4.3/4"	AHX-32RL412	4.3/4"
				AHX-4RL211	2.11/16"	AHX-6RL309	3.9/16"	AHX-8RL405	4.5/16"	AHX-16RL413	4.13/16"	AHX-32RL413	4.13/16"
				AHX-4RL212	2.3/4"	AHX-6RL310	3.5/8"	AHX-8RL406	4.3/8"	AHX-16RL414	4.7/8"	AHX-32RL414	4.7/8"
				AHX-4RL213	2.13/16"	AHX-6RL311	3.11/16"	AHX-8RL407	4.7/16"	AHX-16RL415	4.15/16"	AHX-32RL415	4.15/16"
				AHX-4RL214	2.7/8"	AHX-6RL312	3.3/4"	AHX-8RL408	4.1/2"	AHX-16RL416	4.9/16"	AHX-32RL416	4.9/16"
				AHX-4RL215	2.15/16"	AHX-6RL313	3.13/16"	AHX-8RL409	4.9/16"	AHX-16RL417	4.13/16"	AHX-32RL417	4.13/16"
				AHX-4RL300	3"	AHX-6RL314	3.7/8"	AHX-8RL410	4.5/8"	AHX-16RL418	4.11/8"	AHX-32RL418	4.11/8"
				AHX-4RL301	3.1/16"	AHX-6RL315	3.15/16"					AHX-32RL419	4.15/16"
				AHX-4RL302	3.1/8"	AHX-6RL400	4"					AHX-32RL420	4.3/8"
												AHX-32RL421	4.5/8"
												AHX-32RL422	4.7/8"
												AHX-32RL423	4.9/8"
												AHX-32RL424	5.1/8"
												AHX-32RL425	5.3/8"
												AHX-32RL426	5.5/8"
												AHX-32RL427	5.7/8"
												AHX-32RL428	5.9/8"
												AHX-32RL429	6.1/8"
												AHX-32RL430	6.3/8"
												AHX-32RL431	6.5/8"
												AHX-32RL432	6.7/8"
												AHX-32RL433	6.9/8"
												AHX-32RL434	7.1/8"
												AHX-32RL435	7.3/8"
												AHX-32RL436	7.5/8"
												AHX-32RL437	7.7/8"
												AHX-32RL438	7.9/8"
												AHX-32RL439	8.1/8"
												AHX-32RL440	8.3/8"
												AHX-32RL441	8.5/8"
												AHX-32RL442	8.7/8"
												AHX-32RL443	8.9/8"
												AHX-32RL444	9.1/8"
												AHX-32RL445	9.3/8"
												AHX-32RL446	9.5/8"
												AHX-32RL447	9.7/8"
												AHX-32RL448	9.9/8"
												AHX-32RL449	10.1/8"
												AHX-32RL450	10.3/8"
												AHX-32RL451	10.5/8"
												AHX-32RL452	10.7/8"
												AHX-32RL453	10.9/8"
												AHX-32RL454	11.1/8"
												AHX-32RL455	11.3/8"
												AHX-32RL456	11.5/8"
												AHX-32RL457	11.7/8"
												AHX-32RL458	11.9/8"
												AHX-32RL459	12.1/8"
												AHX-32RL460	12.3/8"
												AHX-32RL461	12.5/8"
												AHX-32RL462	12.7/8"
												AHX-32RL463	12.9/8"
												AHX-32RL464	13.1/8"
												AHX-32RL465	13.3/8"
												AHX-32RL466	13.5/8"
												AHX-32RL467	13.7/8"
												AHX-32RL468	13.9/8"
												AHX-32RL469	14.1/8"
												AHX-32RL470	14.3/8"
												AHX-32RL471	14.5/8"
												AHX-32RL472	14.7/8"
												AHX-32RL473	14.9/8"
												AHX-32RL474	15.1/8"
												AHX-32RL475	15.3/8"
												AHX-32RL476	15.5/8"
												AHX-32RL477	15.7/8"
												AHX-32RL478	15.9/8"
												AHX-32RL479	16.1/8"
												AHX-32RL480	16.3/8"
												AHX-32RL481	16.5/8"
												AHX-32RL482	16.7/8"
												AHX-32RL483	16.9/8"
												AHX-32RL484	17.1/8"
												AHX-32RL485	17.3/8"
												AHX-32RL486	17.5/8"
												AHX-32RL487	17.7/8"
												AHX-32RL488	17.9/8"
												AHX-32RL489	18.1/8"
												AHX-32RL490	18.3/8"
												AHX-32RL491	18.5/8"
												AHX-32RL492	18.7/8"
												AHX-32RL493	18.9/8"
												AHX-32RL494	19.1/8"
												AHX-32RL495	19.3/8"
												AHX-32RL496	19.5/8"
												AHX-32RL497	19.7/8"
												AHX-32RL498	19.9/8"
												AHX-32RL499	20.1/8"
												AHX-32RL500	20.3/8"
												AHX-32RL501	20.5/8"
												AHX-32RL502	20.7/8"
												AHX-32RL503	20.9/8"
												AHX-32RL504	21.1/8"
												AHX-32RL505	21.3/8"
												AHX-32RL506	21.5/8"
												AHX-32RL507	21.7/8"
												AHX-32RL508	21.9/8"
												AHX-32RL509	22.1/8"
	</												

↳ QUADRA PORT SYSTEM



The Quadra-Port System eliminates the common “Criss-Cross” bolt tightening pattern that causes crushing or over-torquing of gaskets. With the Quadra-Port System multi-torque wrenches are utilized along with our Quadra-Port Hydraulic Pumps.

Once the wrenches are in place, a single operator can apply even load at the push of a button. The Quadra-Port System will evenly close the gap and apply even torque up to $\pm 3\%$ fast and accurate.



Uneven load using one tool



Even and precise loading with Quadra-Port 4 tool system

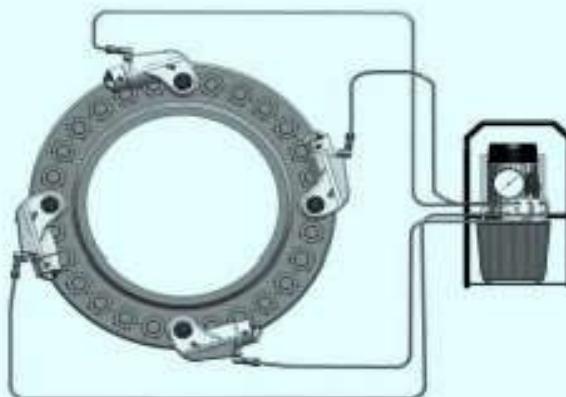

Quadra-Port four tool system

✦ HYDRAULIC BOLTING SERVICES



We offer world class products for industries including oil and gas, power generation, wind energy, and mining.

From general purpose hydraulic bolt tensioners and torque wrenches to electric and pneumatic nut runners,

If our wide range of standard equipment is not suitable for your application, we will design and manufacture a custom application and requirement.

PUMPS USE WITH HYDRAULIC WRENCHES

✦ **AEP-1000 and AAP-1000**

Heavy Duty High Flow High Speed Electrically and Pneumatically Operate Pump.



Mono Port



Quadra Port



AEP-1000 ELECTRIC	AAP-1000 PNEUMATIC
<ul style="list-style-type: none"> • Quadra-Port Multi-Port Manifold (Max. 4 Ports). • Cool running continuous duty axial piston pump. • Single phase Induction motor. • 115V and 230V available. • Quiet operation (approx. 80 dBA @ 10,000 PSI). • Rugged remote pendant to control motor and valve. • Easily adjustable pressure control knob. • Auto-dump relieves oil pressure from hoses. • Completely enclosed motor and electronics. • 2 Gallon oil reservoir. • Precise PSI/BAR pressure gauge. • Quick-connect no-drip couplers with safety locking collar. • Supplied with dual non-conductive high pressure hose with couplers. • Starts under full load. • Runs on reduced voltage 	<ul style="list-style-type: none"> • Quadra-Port Multi-Port Manifold (Max. 4 Ports). • Cool running continuous duty axial piston pump. • Powerful 1.5HP Industrial duty air motor. • Runs on 50 cfm / 80 PSI of air. • Quiet operation (approx. 80 dBA @ 10,000 PSI). • Rugged remote pendant to control motor and valve. • Easily adjustable pressure control knob. • Auto-dump relieves oil pressure from hoses. • Filter-lubricator for long trouble free operation. • 2 Gallon oil reservoir. • Precise PSI/BAR pressure gauge. • Quick-connect no-drip couplers with safety locking collar. • Supplied with dual non-conductive high pressure hose with couplers

POWER HYDRAULIC NUT SPLITTERS

🔧 NUT SPLITTER FEATURES & SPECIFICATIONS

Safe : No sparks. No flames. No risk to volatile surroundings. No hammers or impact needed. No flying fragments.

Fast : Cuts a 3" nut in 20 to 30 seconds vs. approx. 20 minutes with a hammer & chisel or torch.

Easy Set up : You can be up and away in less than 5 minutes. No Damage to bolt or stud threads by calibrating the chisel so that only the nut is cut.

Versatile : Power splitters cut the hardest nuts. The range of models offered and the range of each model compares very favourably vs. the competition.

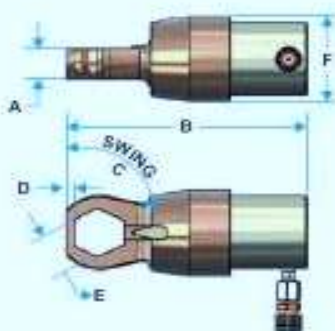

STANDARD NUT SPLITTERS

MODEL NO	STUD DIAMETER		NUT A/F		A	B	C	D	E	F	WEIGHT	
	mm	inch	mm	inch	mm	mm	mm	mm	mm	mm	kg	lbs
APS-105	11-12	7/16-7/8	16-36	5/8-1.7/16	38	271	60°	10	38	105	10.7	23.6
APS-200	22-32	7/8-1.1/4	36-51	1.7/16-2	38	287	45°	13	54	108	11.3	24.9
APS-204	32-38	1.1/4-1.1/2	46-60	1.13/16-2.3/8	57	385	30°	14	64	164	35.5	78.3
APS-210	35-45	1.3/8-2.1/4	57-70	2.1/4-2.3/4	57	398	30°	18	73	164	36.5	80.5
APS-308	45-57	1.3/4-2.1/4	70-89	2.3/4-3.1/2	78	460	30°	19	99	214	75.2	165.8
APS-314	50-64	2-2.1/4	79-89	3.1/8-3.7/8	80	488	30°	22	108	214	82	180.8
APS-404	64-70	2.1/2-2.3/4	95-108	3.3/4-4.1/4	95	579	60°	29	118	251	106	233.7
APS-500	76-83	3-3.1/4	114-127	4.1/2-5	105	590	60°	29	137	251	111	244.7
APS-506	83-89	3.1/4-3.1/2	124-136	4.7/8-5.3/58	105	598	60°	29	149	251	108.5	239.2

ANGLE HEAD NUT SPLITTER

MODEL NO	STUD DIAMETER		NUT A/F		A	B	C	D	E	F	WEIGHT	
	mm	inch	mm	inch	mm	mm	mm	mm	mm	mm	kg	lbs
APS-100AH	11-16	7/16-5/8	13-24	1/2-1	17.5	190	30°	6	65	72	4.5	9.9
APS-105AH	11-12	7/16-7/8	16-36	5/8-1.7/16	38	280	60°	10	70	105	11	24.3
APS-200AH	22-32	7/8-1.1/4	36-51	1.7/16-2	38	290	45°	13	95	108	12.5	27.6
APS-204AH	32-38	1.1/4-1.1/2	46-60	1.13/16-2.3/8	57	410	30°	15	108	164	38	83.8
APS-210AH	35-45	1.3/8-2.1/4	57-70	2.1/4-2.3/4	57	420	30°	18	130	164	40	88.2
APS-308AH	45-57	1.3/4-2.1/4	70-89	2.3/4-3.1/2	78	500	30°	20	160	214	78	172.0
APS-314AH	50-64	2-2.1/4	79-89	3.1/8-3.7/8	80	510	30°	23	175	214	86	189.6
APS-404AH	64-70	2.1/2-2.3/4	95-108	3.3/4-4.1/4	95	600	60°	32	210	251	112	246.9
APS-500AH	76-83	3-3.1/4	114-127	4.1/2-5	105	620	60°	34	230	251	118	260.1
APS-506AH	83-89	3.1/4-3.1/2	124-136	4.7/8-5.3/58	105	650	60°	36	250	251	124	273.4

POWER FLANGE SPREADERS

✦ MANUAL AND HYDRAULIC POWER SPRADER



SPECIFICATION	AMS-10P		AHS-10P	
	IMPERIAL	METRIC	IMPERIAL	METRIC
WIDTH OF JAW	4.5"	114 mm	4.5"	114 mm
WIDTH OF BODY	4"	101 mm	4"	101 mm
JAW OPEN	3"	76.2 mm	3"	76.2 mm
JAW CLOSE	0.9"	2.3 mm	0.9"	2.3 mm
JAW GAP	1.5"	38.1 mm	1.5"	38.1 mm
WIGHT	17.0 Lbs	7.70 Kg	15.5 Lbs	7.0 Kg
LENGTH	14"	35.5 m	13.25'	33.6 m
FORCE	10000 Lbs	4.5 Ton	10000 Lbs	4.5 Ton



MANUAL SPRADER

- **Manual Power-Spreader AMS10P** : simply place the tips between the flange faces and turn the ratcheted handle. The ratcheting action is transformed into 4535 Kg (10,000 lbs.) Of spreading force and creates up to 76.2 mm (3") of gap.

HYDRAULIC SPRADER

- **Hydraulic Power-Spreader AHS10P** : A hydraulic cylinder replaces the ratchet handle. A standard hand pump powers 1 Power-Spreader, or a pair, with ease. When supplied with 4535 kg (10,000 lbs) of force and 76.2 mm (3") of gap; ample for gasket replacement or turning of blinds.



✦ HYDRAULIC FLANGE SPREADERS

- **Hydraulic Flange Spreaders are used for safety opening pipe flanges.**
- **Available in capacities of 5 tons and 10 tons the versatility of both models enables the user to open flanges up to 92mm thick.**
- **Operated with a standard hydraulic hand pump and connecting hose and supplied in a handy steel storage case,**
- **Hydraulic Flange Spreaders can be operated individually, or as a pair when opening large diameter flanges.**
- **Hydraulic Flange Spreaders takes minutes to open the toughest flanges without the risks of sparks caused by hammer blows and chisels.**

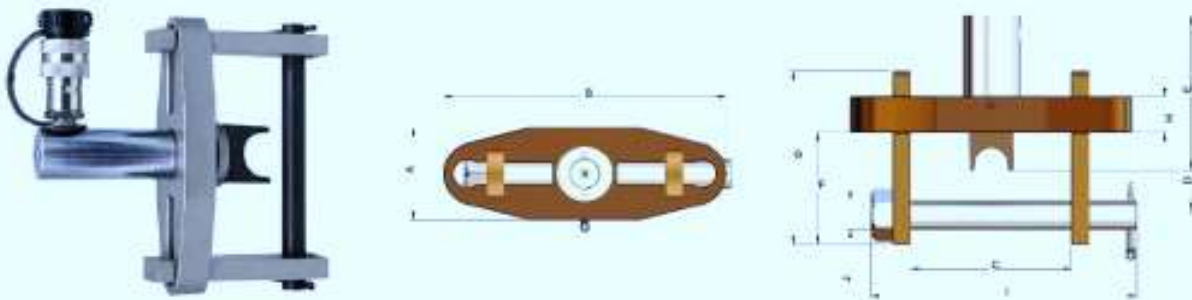

AFS-50 & AFS-100

DIMENSIONS:

MODEL NO	A	B	C		D	E	F	G	H	I	J
			MIN	MAX							
AFS-50	77	210	61	157	10	192	69	131	25	205	18
AFS-100	110	290	61	226	30	165	89	180	38	274	31

TECHNICAL :

MODEL NO	CAPACITY	STROKE	OIL CAPACITY	MAX.FLANGE THICKNESS	FLANGE DIAMETER	STUD SIZE	STANDARD WEDGE	OPTIONAL WEDGW
	TONNES	mm	cm ³	mm	mm(Inch)	mm	mm	mm
AFS-50	5	39	25	2 X 58	1150 mm(45")	19-29	3-29	30-56
AFS-100	10	55	78	2 X 93	1900 mm (75")	32-41	3-29	30-56

HYDRAULIC VERTICAL LIFTING & SPREADING WRENCHES

✦ HYDRAULIC VERTICAL LIFTING WEDGE – AVW-10H

- **Lifting force - 16 Tons per tool.**
- **Lift in a straight vertical place.**
- **Access gap of only 3/8" (9.5mm) needed.**
- **3/4" (19.0mm) of vertical lift available from each step.**
- **Max. height of 50mm on 4th step.**
- **Automatic spring return retraction.**
- **Interlocking first step ensures safe hold.**
- **No Slippage due to locking.**

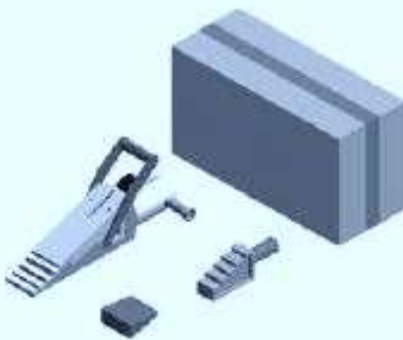

MINI KIT

- **1 x Hydraulic Vertical Lifting Wedge Assembly**
- **1 x Safety Block**
- **1 x Instruction Manual**
- **1 x Carry Case**



STANDARD KIT

- **1 x Hydraulic Vertical Lifting Wedge Assembly**
- **1 x 10,000 psi (700 Bar) Two Stage Hydraulic Hand Pump**
- **1 x 10,000 psi (700 Bar) Hydraulic Hose Length 6 feet**
- **1 x Safety Block**
- **1 x Stepped Block**
- **1 x Instruction Manual**
- **1 x Carry Case**

✦ HYDRAULIC SPREADING WEDGE – ASW-10H

- **Only requires an access gap of 1/4" (6 mm)**
- **Locking at first step ensures on slippage increased safety**
- **Robust Light weight Tool-Just 7.2 kg (16 lbs)**
- **10,000 psi (700 Bar) generates 14.0 Tons spreading force.**
- **Automatic Spring Return.**



MINI KIT



STANDRAD KIT



MAXI KIT

2 x Hydraulic Spreading Wedge Assembly
1 x 10,000 psi (700 Bar)
Two Stage Hydraulic Hand Pump
2 x 10,000 psi (700 Bar) Hydraulic Hoses
2 x Safety Block
1 x Instruction Manual
1 x Carry Case
1 x 10,000 psi Twin Valve manifold
Gross Weight: 28 kg

CLASSIC MECHANICAL CLICK TORQUE WRENCHES

Classic Mechanical Torque Wrenches have proved themselves reliable and accurate over many years of full service, mastering every conceivable nut tightening operation in all areas of industry.



Classic Mechanical Torque Wrenches are available in following three types

- + Standard Torque Wrenches:** Adjustable click type torque wrenches

- + Ratcheting Torque Wrenches:** In built ratcheting mechanism provisional for ease of operation without effecting accuracy & life.

- + Production Torque Wrenches:** These torque wrenches are available in both standard & ratcheting but have a fixed torque value set to prevent any tempering by operation.

HYDRAULIC BOLT TENSIONERS

- **Bolt tensioning is the preferred method of tightening bolts and studs on all critical applications.**
- **Bolt tensioners are designed for operation in a wide variety of applications including pipeline flanges, heat exchangers, pressure vessels, compressor covers, boiler feed pumps, windmills and many others.**
- **We provide a comprehensive range of bolt tensioners for optimum solutions to bolt tensioning requirements.**
- **Our Bolt tensioners and accessories are CE marked in accordance with Pressure Equipment and Machinery Directives, as applicable. In comparison to traditional tightening methods, tightening with bolt tensioners offers significant advantages:**
 - **No torsional loading of fasteners.**
 - **Direct loading - no damage to assembly.**
 - **Easy and fast operation with very high accuracy and repeatability.**
 - **Automation feasible and can be used for critical applications.**
 - **AHT tensioners are designed to provide a wide range of flexibility, covering stud sizes 3/4" to 5.3/4" (M-18 to M-150).**

AHT BOLT TENSIONERS:



The AHT Bolt Tensioner is very simple to use and consists of only four parts



ASS SUB SEA BOLT TENSIONERS:

- **ASS Series Bolt Tensioners are specially designed for subsea applications.**
- **ASS Tensioners are suitable for higher pressure rating flanges**
- **It's ergonomic design makes it very easy to handle and use by divers under the harsh sea conditions.**
- **ASS tensioners are designed to provide a wide range of flexibility, covering stud sizes 3/4" to 3.1/2" (M-18 to M-85).**



The tool consists of two basic parts - Tensioning Unit and Lock Nut



