



INDVAC PUMPS



Technical Data sheet

Pump type : Oil sealed Rotary Vane Vacuum pump

Model : IVP 250

Stage : Two stages



Technical Specifications

Parameters	Units	IVP 250
Pumping speed/Flow	LMP	250
	CFM	8.8
	m ³ /hr	15
Ultimate vacuum	mbar/Torr	5x10 ⁻³ /3.7x10 ⁻³
Ultimate vacuum with gas ballast	mbar/Torr	5x10 ⁻² /3.7x10 ⁻²
Motor power rating	HP/KW	0.5/0.372
Rotational speed	RPM	1440
Oil Capacity	lts	1.1
Inlet connection	--	KF 25
Exhaust connection (plain nozzle)		3/4 "
Weight	Kg	32
Overall dimension(L/W/H)	mm	525/190/225

Indvac Pumps

B-167/1, 4th Main, 2nd Stage Peenya Indl Area, Bangalore- 58.

Ph:080-28367812 / 9845845122 | Email: indvacpumps@gmail.com | Web: <http://indvacpumps.com/>

INDVAC PUMPS

Pump Schematic

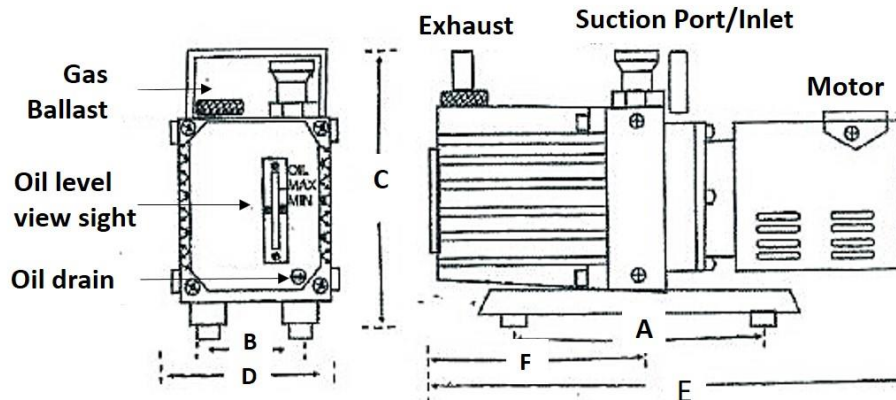

Pump Dimensions (in mm)

Model	A	B	C	D	E	F
IVP 250	270	131	255	186	525	225

Features:

- Built in anti-suck back
- Light and compact
- Low noise and vibration
- Forced lubrication
- Gas ballast
- Fully O ring sealed
- Easy maintenance

Application:

- Degassing and Freeze Drying
- Refrigeration & Airconditioning
- Vacuum Distillation & Drying
- Research and Development
- Pharmaceutical & Chemical
- Vacuum Impregnation
- Vacuum Forming, Packing & Clamping
- Evacuation of Bulbs, TV Tubes, Transformers & Vacuum Systems

Indvac Pumps

B-167/1, 4th Main, 2nd Stage Peenya Indl Area, Bangalore- 58.

Ph:080-28367812 / 9845845122 | Email: indvacpumps@gmail.com | Web: <http://indvacpumps.com/>