

**FKD<sup>®</sup> 海蓝轴承**  
BEARING 外球面带座轴承专业制造商

**FKD<sup>®</sup>**  
BEARING



**河北海蓝轴承制造有限公司**

HEBEI HAILAN BEARING MANUFACTURE CO.,LTD

地址：河北省临西县河西镇工业园区 054901

ADD: Hexi Town Industrial Park, Linxi County, Hebei, China

电话/TEL: 0086-319-8542274(Factory)

0086-319-8542291(Factory)

0086-319-3725658(Factory)

传真/FAX: 0086-319-8542290(Factory)

0086-635-2970300(Int'l Dept)

0086-635-2970399(Int'l Dept)

0086-311-66689635(Int'l Dept)

0086-635-2970355(Int'l Dept)

网址/Web: <http://www.ok-bearing.com>

E-mail: [fkd.services@ok-bearing.com](mailto:fkd.services@ok-bearing.com)

**河北海蓝轴承制造有限公司**

HEBEI HAILAN BEARING MANUFACTURE CO.,LTD

# 公司简介

河北海蓝轴承制造有限公司（原邢台洪海轴承有限公司，创建于1988年）是中国产量最大、品种最齐全的外球面带座轴承制造工厂和出口商之一。是河北省著名商标及河北省优质产品企业。位于中国轴承之乡，临西，地理位置优越，交通便利。公司致力于外球面轴承和各类轴承座的研发、生产和推广应用。

公司现有员工500余人，各类工程技术人才50多人，公司占地100000平方米，厂房建筑占地65000多平方米，拥有中国最先进的外球面轴承生产自动线、自动检测线和国际领先的轴承座生产线。公司秉承“产品差异化，技术现代化，制造专业化，品质高档化，成本低廉化”的经营理念，年产、销带座轴承、深沟球轴承、圆锥滚子轴承等各类轴承1900万套，产品广泛应用于各类传动设备、矿山机械、工程机械、纺织机械、农业机械、林业机械、建筑机械等。

我们公司已通过ISO9001:2008和GB/T19001-2008质量管理体系认证。生产线全部采用目前国内最先进的专用设备，自动化程度达到90%，技术工艺先进，检测手段齐全，质量管理体系完善。公司采用国际标准技术质量标准，以先进的制造工艺和现代化科技管理手段，为广大用户提供高质量产品。“FE、FKD、HHB”在国内及海外已申请注册为本公司商标。销售网络遍布全国各省，其中90%的数量出口到世界68个国家和地区，是我国最早的轴承出口基地企业之一，与世界各地合作伙伴形成了长期的战略合作关系，在国内、外建立了强大的营销网络和服务平台。

海蓝轴承大力倡导“团结、互助、合作、双赢”的企业文化，坚持以人为本，着力引进专业人才，强化员工培训，提高员工素质，增强企业竞争力。公司全体员工竭诚希望与海内外广大用户真诚合作，共图发展！

让我们在相识、合作、成功的道路上携手共进！您的需求就是我们的追求！

因为专一，所以专业！

# Company profile

Hebei Hailan Bearing Manufacture Co.,Ltd (originally founded in 1988 as Xingtai Honghai Bearing Manufacture Co.,Ltd) is one of the Chinese leading bearing manufacturers and exporters with the largest outputs and the greatest varieties. It is the enterprise of well-known trademark and high quality products of Hebei, located in the Bearing Hometown of LinXi county, HeBei Province, North of China,. We devote ourselves to research & development, production, promotion and application of pillow block bearing and other kinds of bearings .

There are over 500 employees, including more than 50 technicians and engineers in our group. With the area of 100000sqm ( Plant 65000+ sqm ) , we have the most advanced pillow block bearing automatic production line, automatic inspection line and the world's leading bearing housing production line. Committing to the philosophy of “products differentiation , technology modernization, manufacture professionalization, quality top grade, cost competition” , we have an annual production of over 19000000 pcs of pillow blocks , deep groove ball bearings, taper roller bearings and other kinds of bearings. Our products are widely used in various types of transmission equipment, mining machinery, engineering machinery, textile machinery, agricultural machinery, forestry machinery, construction machinery and so on .

Our company has approved by ISO9001:2008 and GB / T 19001-2008 quality management system certification. All of our production lines adopt the most advanced specialized equipment, with a high automation level of 90%! Up to the international standards of technical quality, we adopt the advanced manufacturing processes and modern technology and management tools to provide customers with high quality products. Our three registered brand FE,FKD,HHB are well-known all over the world. Over 90% of the products are exported to more than 68 countries and regions around the world. As one of the Chinese earliest bearing-exported enterprises, we have built the long-term strategic partnership with our customers, establishing the strong marketing network and service platform in the domestic and over sea market.

With our corporate culture of "unity, assistance, cooperation and mutual benefits", HeBei Hailan Bearing Manufacture Co.,Ltd adheres to the people-oriented philosophy , focuses on the recruit of professionals, staff training, and enhances the competitiveness of the enterprise. All of us in the company sincerely hope to cooperate with all the clients in good faith to promote the common development !

Let' s make progress together on the way of acquaintance, cooperation, success !

Strong commitment makes us professional!



品牌篇  
BRAND CHAPTER

文化篇  
CULTURE CHAPTER



荣获河北省优质产品

荣获河北名牌产品

被认定为河北省著名商标

被认定为邢台市知名商标

企业宗旨  
提供优质产品 创造社会价值

企业精神  
诚信、务实、高效、创新

企业愿景  
打造一流品牌、争做行业先锋

经营理念  
服务市场，创造市场，引领市场

生存理念  
机会源于创造

产品理念  
品质源于责任，服务彰显价值



因为专一·所以专业

Strong commitment makes us professional!

## 生产篇 PRODUCTION CHAPTER

我们将不断推进技术进步，  
加快技术改革步伐，  
采用先进技术满足高科技产品要求。

We shall continue to upgrade the technology, speed up technical innovation and adopt advanced technology to meet the standard of high-tech products.



精良的制造工艺，  
一流的设备装置。

Advanced production technology,  
first-class production line.



不懈的追求，  
开创恒久的辉煌。

Unremitting pursuing,  
long-lasting success.

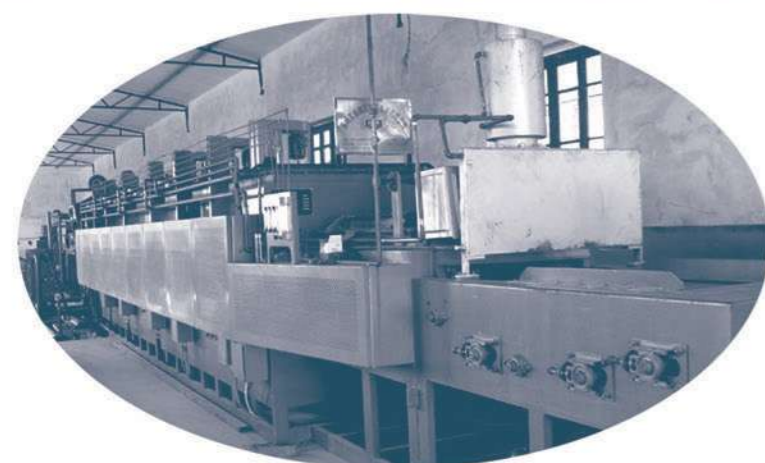

生产篇  
PRODUCTION CHAPTER



质量篇  
QUALITY CHAPTER



持续创新是我们的使命……  
Constant innovation is our mission.







# 目录

## Catalog

轴承与座结合表.....1 BEARINGS AND HOUSINGS MATCHING TABLE	悬挂式座 UCFB200.....26 FLANGE BRACKET UNITS
轴承材质.....2 BEARING MATERIAL	悬吊式座 UCHA200.....27 SCREW CONVEYOR HANGER UNITS
带座轴承的精度.....3 BEARING UNITS PRECISION	环形座 UCC200.....28 CARTRIDGE UNITS
轴承座公差.....7 HOUSING TOLERANCE	带冲压立式座外球面轴承.....29 BEARING UNITS WITH PRESSED HOUSING
外球面轴承的极限转速.....9 BEARING UNITS MAXIMUM SPEED	带冲压菱形座外球面轴承.....30 BEARING UNITS WITH PRESSED HOUSING ( OVAL )
带座轴承的润滑和工作温度.....10 LUBRICATION AND OPERATING TEMPERATURE OF BEARING UNITS	带冲压圆形座外球面轴承.....31 BEARING UNITS WITH PRESSED HOUSING ( CARTRIDGE )
立式座 UCP200.....11 PILLOW BLOCKS	带冲压三角形座外球面轴承.....32 BEARING UNITS WITH PRESSED HOUSING ( TRIANGLE )
立式座 UCPX00.....12 PILLOW BLOCKS	带顶丝外球面球轴承 UC200.....33 BALL BEARINGS(WITH SETSCREWS)
立式座 UCP300.....13 PILLOW BLOCKS	带顶丝外球面球轴承 UCX00.....34 BALL BEARINGS(WITH SETSCREWS)
方形座 UCP200.....14 FLANGE UNITS(SQUARE)	带顶丝外球面球轴承 UC300.....35 BALL BEARINGS(WITH SETSCREWS)
方形座 UCFX00.....15 FLANGE UNITS(SQUARE)	带偏心套外球面球轴承 HC200.....36 BALL BEARINGS(WITH ECCENTRIC LOCKING COLLER)
方形座 UCF300.....16 FLANGE UNITS(SQUARE)	带圆锥孔外球面球轴承 UK200.....37 BALL BEARINGS(WITH TAPERED BORE)
菱形座 UCFL200.....17 FLANGE UNITS(OVAL)	带止动环深沟球轴承 SER200.....38 BALL BEARINGS(WITH LOCATING SNAP RING)
菱形座 UCFLX00.....18 FLANGE UNITS(OVAL)	带偏心套球轴承.....39 BALL BEARINGS(WITH ECCENTRIC COLLAR)
菱形座 UCFL300.....19 FLANGE UNITS(OVAL)	带偏心套球轴承.....40 BALL BEARINGS(WITH ECCENTRIC COLLAR)
滑块座 UCST200 UCT200.....20 TAKE-UP UNITS(NORMAL-DUTY)	带顶丝球轴承.....41 BALL BEARINGS(WITH SETSCREWS)
滑块座 UCT300.....21 TAKE-UP UNITS(NORMAL-DUTY)	农机轴承.....42 AGRI-BEARING SQUARE BORE WITHOUT GREASE NIPPLE
凸台圆形座 UCFC200.....22 FLANG CARTRIDGE UNITS	深沟球轴承.....43 DEEP GROOVE BALL BEARING
高中心立式座 UCPH200.....23 PILLOW BLOCKS(HIGH CENTER HEIGHT)	调心滚子轴承.....45 SPHERICAL ROLLER BEARING
高中心立式座 UCPA200.....24 PILLOW BLOCKS(HIGH CENTER HEIGHT)	推力球轴承.....46 THRUST BALL BEARING
可调菱形座 UCFA200.....25 ADJUSTABLE FLANGE UNITS	圆锥滚子轴承.....47 TAPERED ROLLER BEARING

## 轴承与座结合表

BEARINGS AND HOUSINGS MATCHING TABLE

	 UC	 Uk	 NA	 SA	 SB
 P	UCP	UKP	NAP	SAP	SBP
 F	UCF	UKF	NAF	SAF	SBF
 FL	UCFL	UKFL	NAFL	SAFL	SBFL
 T	UCT	UKT	NAT	SAT	SBT
 FC	UCFC	UKFC	NAFC	SAFC	SBFC
 PH	UCPH	UKPH	NAPH	SAPH	SBPH
 PA	UCPA	UKPA	NAPA	SAPA	SBPA
 HA	UCHA	UKHA	NAHA		
 FB	UCFB	UKFB	NAFB		
 FA	UCFA	UKFA	NAFA		
 C	UCC	UKC	NAC	SAC	SBC
 LLP				SALLP	SBLLP
 LF				SALF	SBLF
 FD				SAFD	SBFD
 PP	UCPP	UKPP	NAPP	SAPP	SBPP
 PF	UCPF	UKPF	NAPF	SAPF	SBPF
 PFL	UCPFL	UKPFL	NAPFL	SAPFL	SBPFL

轴承材质:  
BEARING MATERIAL

高碳铬轴承钢GCr15的化学成分(%)

C	Si	Mn	P	S	Cr
0.98 ~ 1.10	0.15 ~ 0.35	< 0.50	< 0.025	< 0.025	1.30 ~ 1.60

轴承座材质:  
HOUSING MATERIAL

HT200的力学性能(%)

主要壁厚(mm)	最小抗拉强度 N/mm <sup>2</sup> (kgf/mm <sup>2</sup> )
≤8	200(20.4)
8 ~ 15	190(19.4)
15 ~ 30	170(17.3)
≥30	160(16.3)

HT200的化学成分(%)

C	Si	Mn	P	S
3.2 ~ 3.5	1.5 ~ 2.0	0.6 ~ 0.9	< 0.30	< 0.10

其它配件材质:  
OTHER ACCESSORIES MATERIAL

配件名称	材质	配件名称	材质
冲压保持架	冷轧钢板08-GB/T 13237	紧定衬套	45#钢-GB/T 699
密封圈	丁腈橡胶、钢板08-GB/T 13237	内六角顶丝	合金结构钢35CrMo-GB/T 3077
护圈	冷轧钢板08-GB/T 13237	油嘴	08L钢-GB/T 699
偏心套	45#钢-GB/T 699	油脂	优质锂基脂
钢球	轴承钢GCr15-GB/T 18254	六角扳手	45#钢-GB/T 699

## 带座轴承的精度

BEARING UNITS PRECISION

外球面轴承精度

轴承径向游隙

外球面轴承的径向游隙是指内圈或外圈中的一个固定,使另一个套圈在径向移动时的移动量。轴承的工作游隙对轴承的疲劳寿命、温升、噪音、振动等性能有影响。

### 圆柱孔外球面轴承径向游隙

RADIAL CLEARANCE OF BEARING UNITS (CYLINDRICAL BORE)

μm

公称内径 d mm		C2组		基本组		C4组		C5组	
超过	到	min.	max.	min.	max.	min.	max.	min.	max.
10	18	3	18	10	25	18	33	25	45
18	24	5	20	12	28	20	36	28	48
24	30	5	20	12	28	23	41	30	53
30	40	6	20	13	33	28	46	40	64
40	50	6	23	14	36	30	51	45	73
50	65	8	28	18	43	38	61	55	90
65	80	10	30	20	51	46	71	65	105
80	100	12	36	24	58	53	84	75	120
100	120	15	41	28	66	61	97	90	140
120	140	18	48	33	81	71	114	105	160

### 圆锥孔外球面轴承径向游隙

RADIAL CLEARANCE OF BEARING UNITS (TAPERED BORE)

μm

公称内径 d mm		C2组		基本组		C4组	
超过	到	min.	max.	min.	max.	min.	max.
10	18	10	25	18	33	25	45
18	24	12	28	20	36	28	48
24	30	12	28	23	41	30	53
30	40	13	33	28	46	40	64
40	50	14	36	30	51	45	73
50	65	18	43	38	61	55	90
65	80	20	51	46	71	65	105
80	100	24	58	53	84	75	120
100	120	28	66	61	97	90	140
120	140	33	81	71	114	105	160

注: 当用有负荷测量仪测量径向游隙时, 径向游隙值必须加上一个修正值。

负荷条件下径向游隙修正值  
MODIFICATION VALUE RADIAL CLEARANCE ( IN LOAD CONDITION )  $\mu\text{m}$

公称内径 d mm		测量负荷	径向游隙修正值		
超过	到	N	C2组	基本组	C4组、C5组
10	18	25	4	4	5
18	30	50	5	5	6
30	50	50	4	4	5
50	80	100	6	7	7
80	100	150	8	8	9

轴承外圈精度  
OUTER RING PRECISION

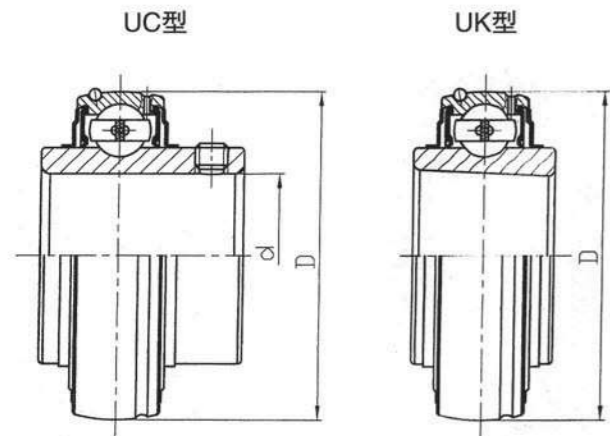

外圈公差  $\mu\text{m}$

D(mm)		$\Delta\text{Dmp}$		Ke	Kea
超过	到	max.	min.	max.	max.
30	50	0	-11	15	20
50	80	0	-13	19	25
80	120	0	-15	26	35
120	150	0	-18	30	40
150	180	0	-25	34	45
180	250	0	-30	38	50
250	315	0	-35		60

轴承内圈精度  
INNER RING PRECISION

圆柱孔内圈公差  
INNER RING TOLERANCE ( CYLINDRICAL BORE )  $\mu\text{m}$

公称内径 d mm		UC,HC,SA,SB,SER			CS			$\Delta\text{Bs,Cs}$		Ki	Kia
超过	到	max.	min.	Vdp	max.	min.	max.	min.	min.	max.	max.
10	18	+15	0	10	0	-8	6	0	-120	11	12
18	30	+18	0	12	0	-10	8	0	-120	11	15
30	50	+21	0	14	0	-12	9	0	-120	13	18
50	80	+24	0	16	0	-15	11	0	-150	16	22
80	120	+28	0	19	-	-	-	0	-200	20	28
120	180	+33	0	22	-	-	-	0	-250	-	35

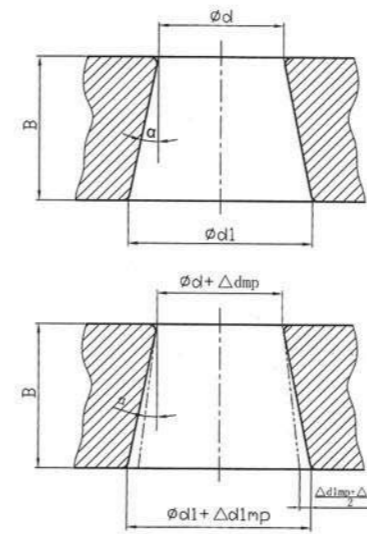

圆锥孔内圈公差  
INNER RING TOLERANCE ( TAPERED BORE )  $\mu\text{m}$

mm		$\Delta\text{dmp}$		$\Delta\text{d1mp} - \Delta\text{dmp}$		Vdp
超过	到	max.	min.	max.	min.	max.
18	30	+33	0	+21	0	13
30	50	+39	0	+25	0	15
50	80	+46	0	+30	0	19
80	120	+54	0	+35	0	25
120	180	+63	0	+40	0	31

轴承座的公差 (精度)  
HOUSING TOLERANCE ( PRECISION )

轴承座内球面直径配合公差  
INNER SPHERICAL SURFACE OF HOUSING DIAMETER TOLERANCE  $\mu\text{m}$

D (mm)		松配合H				过渡配合J				过盈配合K			
超过	到	D1m		D1		D1m		D1		D1m		D1	
超过	到	max.	min.	max.	min.	max.	min.	max.	min.	max.	min.	max.	min.
30	50	+25	0	+30	-5	+14	-11	+19	-16	+7	-18	+12	-23
50	80	+30	0	+36	-6	+18	-12	+24	-18	+9	-21	+15	-27
80	120	+35	0	+42	-7	+22	-13	+29	-20	+10	-25	+17	-32
120	180	+40	0	+48	-8	+26	-14	+34	-22	+12	-28	+20	-36
180	250	+46	0	+55	-9	+30	-16	+39	-25	+13	-33	+22	-42
250	315	+52	0	+62	-10	+36	-16	+46	-26	+16	-36	+26	-46

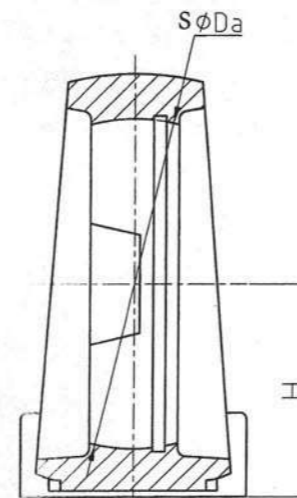

立式座中心高公差  
VERTICAL HOUSING CENTER HEIGHT TOLERANCE  $\mu\text{m}$

轴承座型式	尺寸偏差
P.LP.PH.PA.PW.PE.PK	
203-210X05-X10 305-310	$\pm 150$
211-218X11-X18 311-318	$\pm 200$
- X20 319-318	$\pm 300$

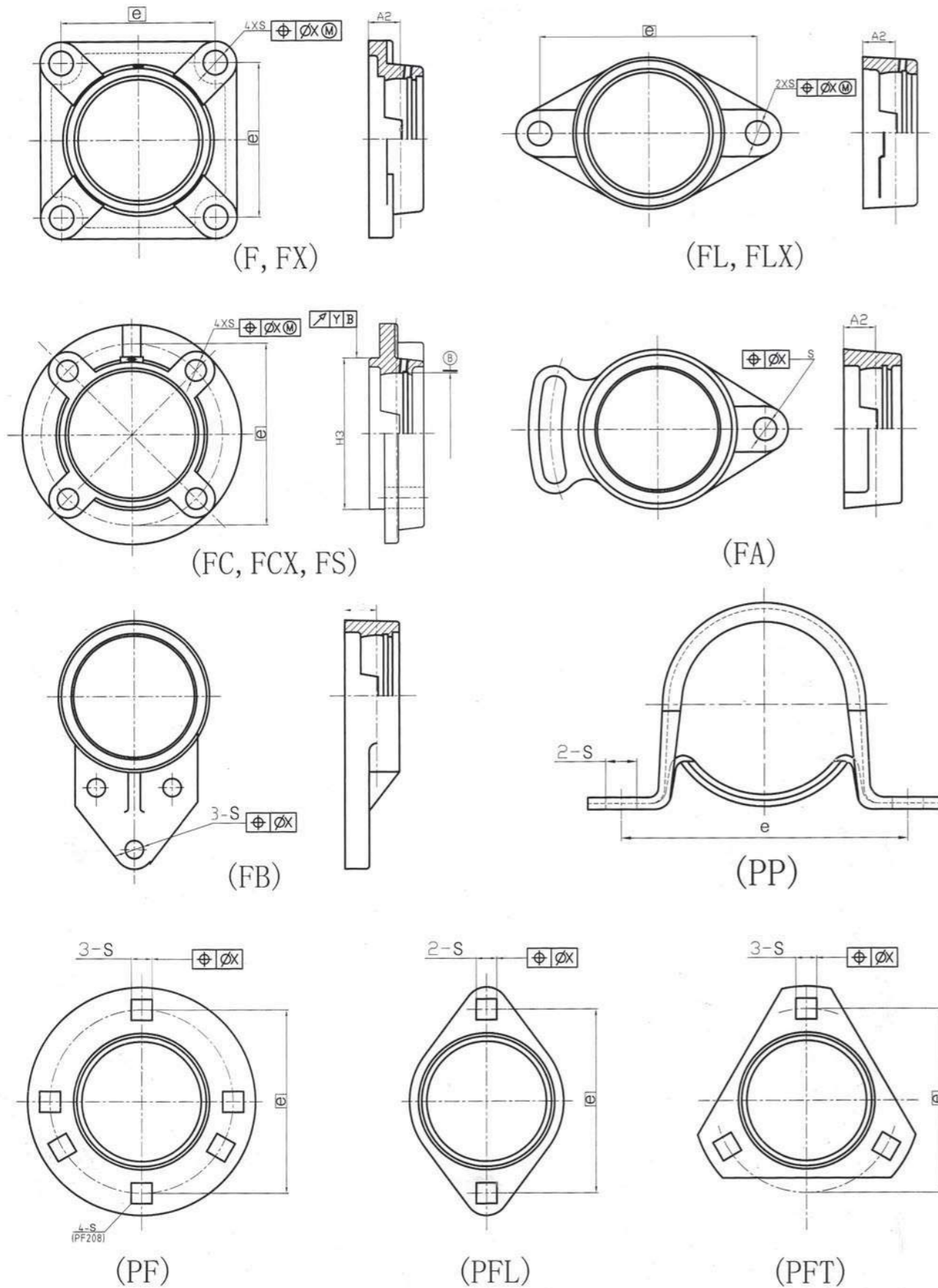

轴承座公差 HOUSING TOLERANCE

μm

轴承座型号 F,FL,FA,FB	X (≤)	ΔA <sub>2</sub>	轴承座型号 FC,FS	凸台尺寸偏差 ΔH <sub>3</sub>						X (≤)	ΔA <sub>2</sub>	Y (≤)																														
				FC 2..		FCX..		FS 3..																																		
				max.	min.	max.	min.	max.	min.																																	
204 - -	700	±500	204 - -	0	-46	0	-46	0	-46	700	±500	200																														
205 X05 305			1000	±800	205 X05 305	0	-54	0	-54				0	-63																												
206 X06 306					206 X06 306										0	-72	0	-72																								
207 X07 307					207 X07 307														0	-81	0	-81																				
208 X08 308					208 X08 308																		0	-89	0	-89																
209 X09 309					209 X09 309																						-	-	-	-												
210 X10 310					210 X10 310																										-	-	-	-								
211 X11 311					211 X11 311																														-	-	-	-				
212 X12 312					212 X12 312																																		-	-	-	-
213 X13 313					213 X13 313																																					
214 X14 314	214 X14 314	-			-					-	-																															
215 X15 315	215 X15 315		-	-		-	-																																			
216 X16 316	216 X16 316							-	-			-	-																													
217 X16 317	217 X16 317													-	-	-	-																									
218 X18 318	218 X18 318																	-	-	-	-																					
- - 319	- - 319																					-	-	-	-																	
- X20 320	- X20 320																									-	-	-	-													
- - 321	- - 321																													-	-	-	-									
- - 322	- - 322																																	-	-	-	-					
- - 324	- - 324																																					-	-	-	-	
- - 326	- - 326	-			-					-	-																															
- - 328	- - 328		-	-		-	-																																			

铸造轴承座未注公差 CASTING HOUSING UNDECLARED TOLERANCE

mm

名义尺寸 (长度)		尺寸偏差 Δ	名义尺寸 (长度)		尺寸偏差 Δ
超过	到		超过	到	
-	120	±1.5	-	-	-
120	250	±2.0	-	10	±1.5
250	400	±3.0	10	18	±2.0
400	800	±4.0	18	30	±3.0
800	1600	±6.0	30	50	±3.5

冲压轴承座公差 PRESSED HOUSING TOLERANCE

mm

轴承座型号	安装孔直径 偏差 ΔS	e 的尺寸偏差	轴承座型号	安装孔尺寸 偏差 ΔS	安装孔位置 偏差 X
PP203-208	±0.5	±0.4	PF203-208 PFL203-208 PFT203-208	±0.2	0.4

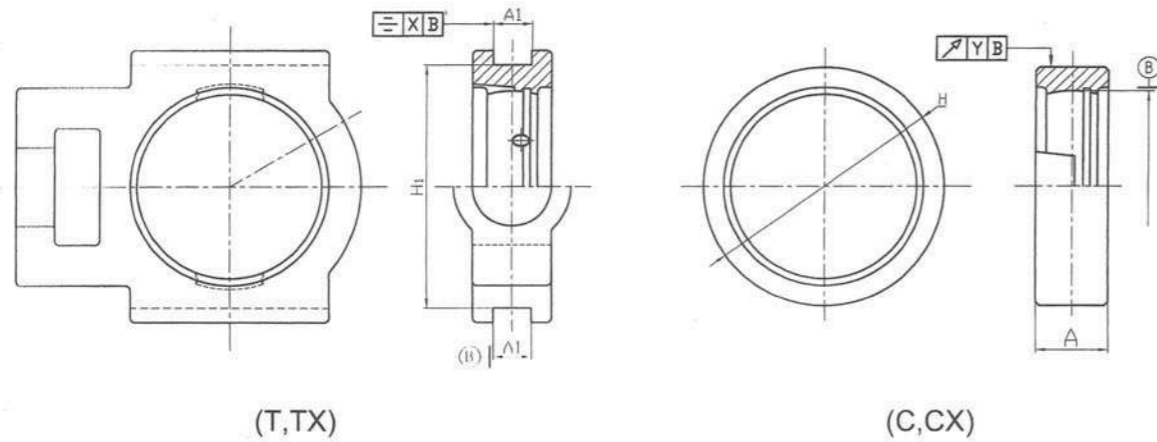

轴承座公差 HOUSING TOLERANCE

轴承座型号 T	$\Delta A_1$	$\Delta H_1$	x ( $\leq$ )	外径公称尺寸偏差 $\Delta H$						Y ( $\leq$ )	$\Delta A$												
				轴承座型号 C		C2..		CX..				C3..											
				max.	min.	max.	min.	max.	min.														
204 - -	+200 0	0 -500	500	204 - -	0	-30	-	-	-	-	200	$\pm 200$											
205 X05 305				0	-35	0	-35	0	-35														
206 X06 306																							
207 X07 307																							
208 X08 308																							
209 X09 309																							
210 X10 310																							
211 X11 311										0			-40	0	-40	0	-40						
212 X12 312																							
213 X13 313																							
214 X14 314																							
215 X15 315																							
216 X16 316																							
217 X17 317																							
- - 318	+300 0	0 -800	600	- - 318	0	-46	0	-46	0	-46	300	$\pm 300$											
- - 319																							
- - 320																							
- - 321																							
- - 322																							
- - 324																							
- - 326																							
- - 328																							
- - 319				700									-	-	-	-	-	0	-52	0	-52	400	$\pm 300$
- - 320																							
- - 321																							
- - 322																							
- - 324																							
- - 326																							
- - 328																							
- - 326	800	-	-		-	-	-	0	-57	0	-57	400											
- - 328																							

外球面轴承的极限转速 BEARING UNITS MAXIMUM SPEED

外球面轴承的极限转速主要取决于轴承工作时产生的摩擦热大小，它与载荷情况、环境湿度、润滑条件及寿命都有密切联系，而轴承与轴的良好配合也是实现高转速的保证。一般情况下，带顶丝类和带偏心套类外球面球轴承与轴采用间隙配合，轴的精度选用h7级公差；当载荷较轻、转速低时，轴的精度可选用h8或h9级公差；当高速、重载荷时，轴承与轴采用较紧的配合，轴的精度采用j7级公差。带紧定套类外球面轴承与轴配合，轴的精度采用h9级公差，并保证IT5/2圆柱度要求，表中用(h9/IT5)表示。

CS200-2RS系列外球面轴承极限转速与深沟球轴承极限转速相当，其极限转速参考值如表所示。

外球面轴承在不同配合下的极限转速参考值如表所示。

外球面轴承极限转速 (参考值) BEARING UNITS MAXIMUM SPEED (REF)

r/min

d (mm)	200系列				300系列				CS200-2RS
	轴的公差				轴的公差				
	js7	h7	h8	h9	js7	h7	h8	h9	
12	6700	5300	3800	1400	-	-	-	-	-
15	6700	5300	3800	1400	-	-	-	-	11000
17	6700	5300	3800	1400	-	-	-	-	10000
20	6000	4800	3400	1200	-	-	-	-	9000
25	5600	4000	3000	1000	5000	3600	2600	900	8000
30	4500	3400	2400	850	4300	3000	2200	800	6700
35	4000	3000	2000	750	3800	2800	2000	700	6000
40	3600	2600	1900	670	3400	2400	1700	630	5600
45	3200	2400	1700	600	3000	2200	1500	560	5000
50	3000	2200	1600	560	2600	2000	1400	500	4800
55	2600	2000	1400	500	2400	1800	1300	450	-
60	2400	1800	1200	450	2200	1700	1100	430	-
65	2200	1700	1100	430	2000	1500	1100	400	-
70	2200	1600	1100	400	1900	1400	1000	360	-
75	2000	1500	1000	380	1800	1300	900	340	-
80	1900	1400	950	340	1700	1200	850	320	-
85	1800	1300	900	320	1600	1100	800	300	-
90	1700	1200	800	300	1500	1100	750	280	-
95	-	-	-	-	1400	1000	700	260	-
100	-	-	-	-	1300	950	670	240	-
105	-	-	-	-	1200	900	630	220	-
110	-	-	-	-	1200	800	600	200	-
120	-	-	-	-	1100	750	530	190	-
130	-	-	-	-	1000	670	480	180	-
140	-	-	-	-	900	600	430	160	-

注：h9/IT5一栏适用于带紧定套外球面轴承，其余j7-h9各栏适用于带顶丝和偏心套外球面轴承。

带座轴承的润滑和工作温度

LUBRICATION AND OPERATING TEMPERATURE OF BEARING UNITS

润滑脂

带座轴承的轴承内，装填防锈润滑脂符合GB7324《锂基润滑脂》规定的2号工业锂基脂，其物理及化学性能参考下表。

润滑脂物理及化学性能表 PHYSICAL AND CHEMICAL PERFORMANCE TABLE OF LUBRICATING GREASE

锥入度 (1/10mm)	265 ~ 295	
滴点 (°C)	≥ 175	
机械杂质 (个/cm <sup>3</sup> )	10 ~ 25µm	不超过5000
	25 ~ 75µm	不超过3000
	75 ~ 125µm	不超过500
	超过125µm	0

工作温度

一般轴承工作温度不超过120°C (外圈测量温度为100°C)，外球面球轴承持续工作温度在70°C以上时，必须考虑缩短再润滑周期，低温极限为不超过零下20°C。

FKD也可提供更高工作温度和更低工作温度的带座轴承，如200°C以下的HT20型，300°C以下的HT30型，以及零下40°C以上的LT40型。

再润滑周期

通常情况下，润滑脂寿命能满足轴承额定的使用期。再润滑型轴承需定期加油脂以保证其长的寿命。

再润滑周期主要由轴承转速、工作温度以及周围环境所决定。再润滑周期可参考下表。

带座轴承再润滑周期表 BEARING UNITS RELUBRICATION TABLE

轴承工作环境	工作温度 (°C)	再润滑周期	
		dn值在50000以下	dn值超过50000
环境干净	<50	不需再润滑	1.5年
	50 ~ 70	1年	6 ~ 12个月
	70 ~ 100	4 ~ 8个月	1 ~ 3个月
	>100	2 ~ 4个星期	1 ~ 2个星期
环境有点脏	<50	1.5年	6 ~ 12个月
	50 ~ 70	4 ~ 8个月	2 ~ 4个月
	70 ~ 100	3 ~ 6个星期	2 ~ 4个星期
	>100	1 ~ 2个星期	每个星期
环境脏	<70	1 ~ 2个月	3 ~ 6个星期
	70 ~ 100	2 ~ 4个星期	1 ~ 2个星期
	>100	1 ~ 7天	1 ~ 3天
环境脏且有水雾	>100	1 ~ 3天	每天

dn值为轴径 (mm) 乘以转速 (转/分钟)

立式座

Pillow Blocks

UCP 200 (normal-duty)

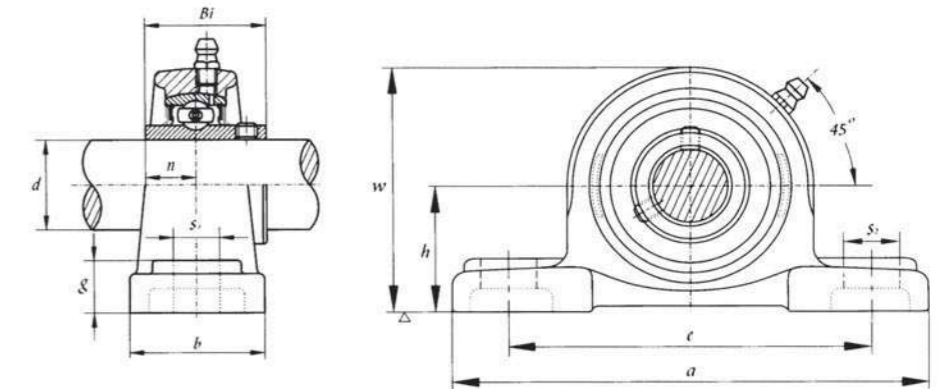

带座轴承代号 Bearing Unit No.	轴 径 Shaft Dia. d		外形尺寸(毫米) Dimensions (mm)										螺 栓 Bolt Used		Bearing No.	Housing No.	重量 Weight (kg)
	(in.)	(mm)	h	a	e	b	s <sub>2</sub>	s <sub>1</sub>	g	w	Bi	n	(mm)	(in.)			
UCP201 201-8	1/2	12	30.2	127	96	38	19	13	15	62	31.0	12.7	M10	3/8	UCP201 201-8	P201	0.61
UCP202 202-10	5/8	15	30.2	127	96	38	19	13	15	62	31.0	12.7	M10	3/8	UCP202 202-10	P202	0.59
UCP203 203-11	11/16	17	30.2	127	96	38	19	13	15	62	31.0	12.7	M10	3/8	UCP203 203-11	P203	0.58
UCP204 204-12	3/4	20	33.3	127	96	38	19	13	15	65	31.0	12.7	M10	3/8	UCP204 204-12	P204	0.61
UCP205-14 205-15 205-16	7/8 15/16 1	25	36.5	140	105	38	19	13	16	70	34.1	14.3	M10	3/8	UCP205-14 205-15 205-16	P205	0.69
UCP206-18 206 206-19 206-20	1 1/8 1 3/16 1 1/4	30	42.9	165	121	48	21	17	18	83	38.1	15.9	M14	1/2	UCP206-18 206 206-19 206-20	P206	1.13
UCP207-20 207-21 207-22 207 207-23	1 1/4 1 5/16 1 3/8 1 7/16	35	47.6	167	126	48	21	17	19	92	42.9	17.5	M14	1/2	UCP207-20 207-21 207-22 207 207-23	P207	1.34
UCP208-24 208-25 208	1 1/2 1 9/16	40	49.2	184	136	54	21	17	19	98	49.2	19.0	M14	1/2	UCP208-24 208-25 208	P208	1.80
UCP209-26 209-27 209-28 209	1 5/8 1 11/16 1 3/4	45	54.0	190	146	54	21	17	20	106	49.2	19.0	M14	1/2	UCP209-26 209-27 209-28 209	P209	1.96
UCP210-30 210-31 210 210-32	1 7/8 1 15/16 2	50	57.2	206	159	60	25	20	22	112	51.6	19.0	M16	5/8	UCP210-30 210-31 210 210-32	P210	2.49
UCP211-32 211-34 211 211-35	2 2 1/8 2 3/16	55	63.5	219	172	60	25	20	22	126	55.6	22.2	M16	5/8	UCP211-32 211-34 211 211-35	P211	2.91
UCP212-36 212 212-38 212-39	2 1/4 2 1/8 2 7/16	60	69.8	241	186	70	25	20	25	137	65.1	25.4	M16	5/8	UCP212-36 212 212-38 212-39	P212	4.4
UCP213-40 213	2 1/2	65	76.2	265	203	70	29	25	27	150	65.1	25.4	M20	3/4	UCP213-40 213	P213	5.17
UCP214-44 214	2 3/4	70	79.4	266	210	72	30	25	27	156	74.6	30.2	M20	3/4	UCP214-44 214	P214	5.57
UCP215 215-47 215-48	2 15/16 3	75	82.6	275	217	74	30	25	28	163	77.8	33.3	M20	3/4	UCP215 215-47 215-48	P215	6.14
UCP216 216-50	3 1/8	80	88.9	292	232	78	28	25	30	175	82.6	33.3	M20	3/4	UCP216 216-50	P216	7.11
UCP217-52 217 217-55	3 1/4 3 7/16	85	95.2	310	247	83	30	25	32	187	85.7	34.1	M20	3/4	UCP217-52 217 217-55	P217	9.18
UCP218-56 218	3 1/2	90	101.6	327	262	88	30	27	34	200	96.0	39.7	M22	7/8	UCP218-56 218	P218	10.63

立式座  
Pillow Blocks

UCPX00 (medium-duty)

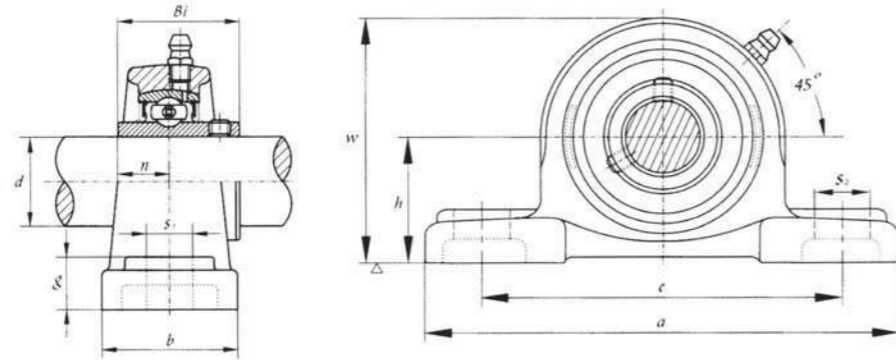

带座轴承代号 Bearing Unit No.	轴 径 Shaft Dia. d		外形尺寸(毫米) Dimensions (mm)										螺 栓 Bolt Used		Bearing No.	Housing No.	重量 Weight (kg)
	(in.)	(mm)	h	a	e	b	s <sub>1</sub>	s <sub>2</sub>	g	w	Bi	n	(mm)	(in.)			
UCPX05 X05-14 X05-16	7/8 1	25	44.4	159	119	51	25	17	18	85	38.1	15.9	M14	1/2	UCX05 X05-14 X05-16	PX05	1.50
UCPX06 X06-18 X06-19 X06-20	1 1/8 1 3/16 1 1/4	30	47.6	175	127	57	25	17	20	94	42.9	17.5	M14	1/2	UCX06 X06-18 X06-19 X06-20	PX06	2.00
UCPX07-20 X07-22 X07 X07-23	1 1/4 1 3/8 1 7/16	35	54.0	203	144	57	30	17	22	105	49.2	19.0	M14	1/2	UCX07-20 X07-22 X07 X07-23	PX07	2.70
UCPX08-24 X08	1 1/2	40	58.7	222	156	67	32	20	26	113	49.2	19.0	M16	5/8	UCX08-24 X08	PX08	3.50
UCPX09-26 X09-27 X09-28 X09	1 5/8 1 11/16 1 3/4	45	58.7	222	156	67	33	20	26	116	51.6	19.0	M16	5/8	UCX09-26 X09-27 X09-28 X09	PX09	3.60
UCPX10-31 X10 X10-32	1 15/16 2	50	63.5	241	171	73	36	20	27	126	55.6	22.2	M16	5/8	UCX10-31 X10 X10-32	PX10	4.40
UCPX11 X11-32 X11-35 X11-36	2 2 3/16 2 1/4	55	69.8	260	184	79	36	25	30	139	65.1	25.4	M20	3/4	UCX11 X11-32 X11-35 X11-36	PX11	6.30
UCPX12 X12-36 X12-38 X12-39	2 1/4 2 3/8 2 7/16	60	76.2	286	203	83	41	25	32	152	65.1	25.4	M20	3/4	UCX12 X12-36 X12-38 X12-39	PX12	7.40
UCPX13-40 X13	2 1/2	65	76.2	286	203	83	41	25	32	154	74.6	30.2	M20	3/4	UCX13-40 X13	PX13	7.70
UCPX14-44 X14	2 3/4	70	88.9	330	229	89	51	27	35	171	77.8	33.3	M22	7/8	UCX14-44 X14	PX14	10.60
UCPX15 X15-47 X15-48	2 15/16 3	75	88.9	330	229	89	51	27	35	175	82.6	33.3	M22	7/8	UCX15 X15-47 X15-48	PX15	11.10
UCPX16 X16-50	3 1/8	80	101.6	381	283	102	59	27	42	195	85.7	34.1	M22	7/8	UCX16 X16-50	PX16	16.20
UCPX17 X17-52	3 1/4	85	101.6	381	283	102	60	27	45	200	96.0	39.7	M22	7/8	UCX17 X17-52	PX17	16.50
UCPX18-56 X18	3 1/2	90	101.6	381	283	111	60	27	45	204	104.0	42.9	M22	7/8	UCX18-56 X18	PX18	18.00
UCPX20 X20-64	4	100	127.0	432	337	121	64	33	52	245	117.5	49.2	M27	1	UCX20 X20-64	PX20	31.80

立式座  
Pillow Blocks

UCP 300 (heavy-duty)

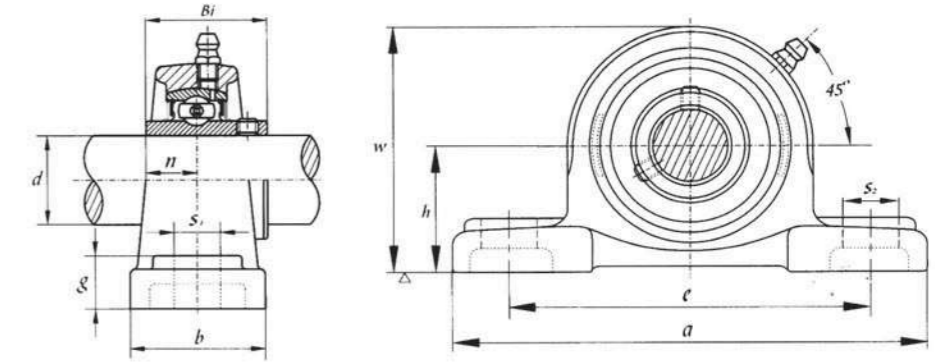

带座轴承代号 Bearing Unit No.	轴 径 Shaft Dia. d		外形尺寸(毫米) Dimensions (mm)										螺 栓 Bolt Used		Bearing No.	Housing No.	重量 Weight (kg)
	(in.)	(mm)	h	a	e	b	s <sub>1</sub>	s <sub>2</sub>	g	w	Bi	n	(mm)	(in.)			
UCP305 305-14 305-16	7/8 1	25	45	175	132	45	20	17	16	85	38	15	M14	1/2	UC305 305-14 305-16	P305	1.28
UCP306-18 306 306-19	1 1/8 1 3/16	30	50	180	140	50	20	17	18	95	43	17	M14	1/2	UC306-18 306 306-19	P306	1.72
UCP307-20 307-21 307 307-23	1 1/4 1 3/8 1 7/16	35	56	210	160	56	25	17	20	106	48	19	M14	1/2	UC307-20 307-21 307 307-23	P307	2.33
UCP308-24 308	1 1/2	40	60	220	170	60	27	17	22	116	52	19	M14	1/2	UC308-24 308	P308	3.01
UCP309-28 309	1 3/4	45	67	245	190	67	30	20	24	129	57	22	M16	5/8	UC309-28 309	P309	3.77
UCP310-31 310	1 15/16	50	75	275	212	75	35	20	27	143	61	22	M16	5/8	UC310-31 310	P310	5.47
UCP311-32 311	2	55	80	310	236	80	38	20	30	154	66	25	M16	5/8	UC311-32 311	P311	6.83
UCP312 312-36	2 1/4	60	85	330	250	85	38	25	32	165	71	26	M20	3/4	UC312 312-36	P312	8.15
UCP313-40 313	2 1/2	65	90	340	260	90	38	25	35	176	75	30	M20	3/4	UC313-40 313	P313	9.41
UCP314-44 314	2 3/4	70	95	360	280	90	40	27	35	187	78	33	M22	7/8	UC314-44 314	P314	11.08
UCP315 315-47 315-48	2 15/16 3	75	100	380	290	100	40	27	35	198	82	32	M22	7/8	UC315 315-47 315-48	P315	13.8
UCP316 316-50	3 1/8	80	106	400	300	110	40	27	40	210	86	34	M22	7/8	UC316 316-50	P316	16.2
UCP317 317-52	3 1/4	85	112	420	320	110	45	33	40	220	96	40	M27	1	UC317 317-52	P317	19.2
UCP318-56 318	3 1/2	90	118	430	330	110	45	33	45	235	96	40	M27	1	UC318-56 318	P318	21.1
UCP319		95	125	470	360	120	50	36	45	250	103	41	M30	1 1/8	UC319	P319	28.2
UCP320 320-64	4	100	140	490	380	120	50	36	50	275	108	42	M30	1 1/8	UC320 320-64	P320	34.8
UCP322		110	150	520	400	140	55	40	50	296	117	46	M33	1 1/4	UC322	P322	43.2
UCP324		120	160	570	450	140	55	40	50	316	126	51	M33	1 1/4	UC324	P324	54.0
UCP326		130	180	600	480	140	55	40	50	355	135	54	M33	1 1/4	UC326	P326	72.1
UCP328		140	200	620	500	140	55	40	60	393	145	59	M33	1 1/4	UC328	P328	91.2

方形座  
Flange Units(Square)

UCF 200 (normal-duty)

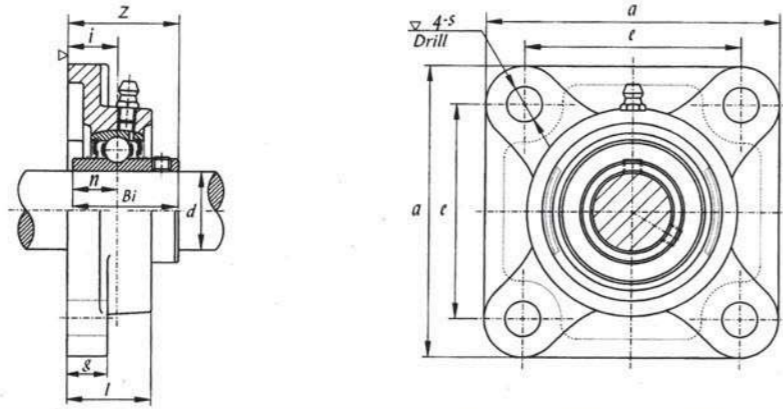

带座轴承代号 Bearing Unit No.	轴 径 Shaft Dia.		外形尺寸(毫米) Dimensions (mm)									螺 栓 Bolt Used		Bearing No.	Housing No.	重量 Weight (kg)
	(in.)	(mm)	a	e	i	g	l	s	Z	Bi	n	(mm)	(in.)			
UCF201 201-8	1/2	12	86	64	15	12	25.5	12	33.3	31	12.7	M10	3/8	UC201 201-8	F201	0.59
UCF202 202-10	5/8	15	86	64	15	12	25.5	12	33.3	31	12.7	M10	3/8	UC202 202-10	F202	0.57
UCF203 203-11	11/16	17	86	64	15	12	25.5	12	33.3	31	12.7	M10	3/8	UC203 203-11	F203	0.56
UCF204-12 204	3/4	20	86	64	15	12	25.5	12	33.3	31	12.7	M10	3/8	UC204-12 204	F204	0.54
UCF205-14 205-15 205	7/8 15/16	25	95	70	16	14	27	12	35.8	34.1	14.3	M10	3/8	UC205-14 205-15 205	F205	0.66
UCF206-18 206 206-19 206-20	1 1/8 1 3/16 1 1/4	30	108	83	18	14	31	12	40.2	38.1	15.9	M10	3/8	UC206-18 206 206-19 206-20	F206	0.93
UCF207-20 207-21 207-22 207 207-23	1 1/4 1 5/16 1 3/8 1 7/16	35	117	92	19	16	34	14	44.4	42.9	17.5	M12	7/16	UC207-20 207-21 207-22 207 207-23	F207	1.2
UCF208-24 208-25 208	1 1/2 1 9/16	40	130	102	21	16	36	16	51.2	49.2	19.0	M14	1/2	UC208-24 208-25 208	F208	1.57
UCF209-26 209-27 209-28 209	1 5/8 1 11/16 1 3/4	45	137	105	22	18	38	16	52.2	49.2	19.0	M14	1/2	UC209-26 209-27 209-28 209	F209	1.76
UCF210-30 210-31 210 210-32	1 7/8 1 15/16 2	50	143	111	22	18	40	16	54.6	51.6	19.0	M14	1/2	UC210-30 210-31 210 210-32	F210	2.05
UCF211-32 211-34 211 211-35	2 2 1/8 2 3/16	55	162	130	25	20	43	19	58.4	55.6	22.2	M16	5/8	UC211-32 211-34 211 211-35	F211	2.96
UCF212-32 212 212-38 212-39	2 1/4 2 3/8 2 7/16	60	175	143	29	20	48	19	68.7	65.1	25.4	M16	5/8	UC212-32 212 212-38 212-39	F212	3.54
UCF213-40 213	2 1/2	65	187	149	30	20	50	19	69.7	65.1	25.4	M16	5/8	UC213-40 213	F213	4.92
UCF214-44 214	2 3/4	70	193	152	31	24	54	19	75.4	74.6	30.2	M16	5/8	UC214-44 214	F214	5.09
UCF215 215-47 215-48	2 15/16 3	75	200	159	34	24	56	19	78.5	77.8	33.3	M16	5/8	UC215 215-47 215-48	F215	5.79
UCF216 216-50	3 1/8	80	208	165	34	22	56	23	78	83.3	33.3	M20	3/4	UC216 216-50	F216	6.91
UCF217-52 217	3 1/4	85	220	175	36	26	63	23	87.6	85.7	34.1	M20	3/4	UC217-52 217	F217	8.63
UCF218-56 218	3 1/2	90	235	187	40	26	68	23	96.3	96.0	39.7	M20	3/4	UC218-56 218	F218	9.5

方形座  
Flange Units(Square)

UCFX00 (medium-duty)

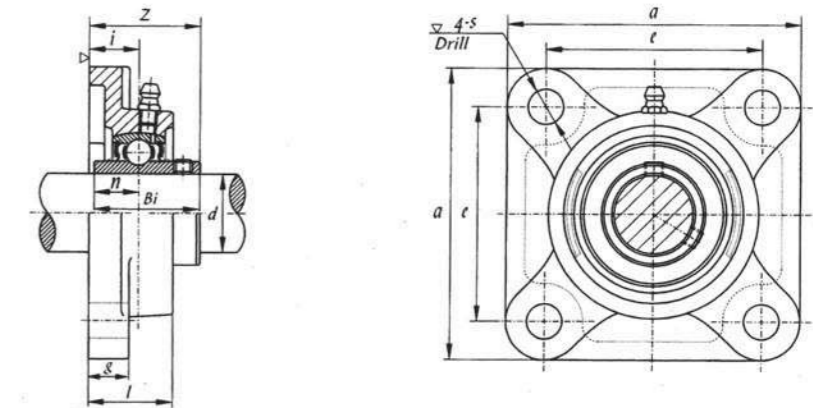

带座轴承代号 Bearing Unit No.	轴 径 Shaft Dia.		外形尺寸(毫米) Dimensions (mm)									螺 栓 Bolt Used		Bearing No.	Housing No.	重量 Weight (kg)
	(in.)	(mm)	a	e	i	g	l	s	Z	Bi	n	(mm)	(in.)			
UCFX05 X05-16	i	25	108	83	18	13	30	12	40.2	38.1	15.9	M10	3/8	UCX05 X05-16	FX05	1.1
UCFX06 X06-19 X06-20	1 3/16 1 1/4	30	117	92	19	14	34	16	44.4	42.9	17.5	M14	1/2	UCX06 X06-19 X06-20	FX06	1.4
UCFX07-20 X07-22 X07 X07-23	1 1/4 1 3/8 1 7/16	35	130	102	21	14	38	16	51.2	49.2	19.0	M14	1/2	UCX07-20 X07-22 X07 X07-23	FX07	1.9
UCFX08-24 X08	1 1/2	40	137	105	22	14	40	19	52.2	49.2	19.0	M16	5/8	UCX08-24 X08	FX08	2.1
UCFX09-26 X09-27 X09-28 X09	1 5/8 1 11/16 1 3/4	45	143	111	23	14	40	19	55.6	51.6	19.0	M16	5/8	UCX09-26 X09-27 X09-28 X09	FX09	2.5
UCFX10-30 X10-31 X10 X10-32	1 7/8 1 15/16 2	50	162	130	26	20	44	19	59.4	55.6	22.2	M16	5/8	UCX10-30 X10-31 X10 X10-32	FX10	3.6
UCFX11 X11-34 X11-35 X11-36	2 1/8 2 3/16 2 1/4	55	175	143	29	20	49	19	68.7	65.1	25.4	M16	5/8	UCX11 X11-34 X11-35 X11-36	FX11	4.7
UCFX12-36 X12 X12-38 X12-39	2 1/4 2 3/8 2 7/16	60	187	149	34	21	59	19	73.7	65.1	25.4	M16	5/8	UCX12-36 X12 X12-38 X12-39	FX12	5.5
UCFX13-40 X13	2 1/2	65	187	149	34	21	59	19	78.4	74.6	30.2	M16	5/8	UCX13-40 X13	FX13	5.9
UCFX14-44 X14	2 3/4	70	197	152	37	24	60	23	81.5	77.8	33.3	M20	3/4	UCX14-44 X14	FX14	7.3
UCFX15 X15-47 X15-48	2 15/16 3	75	197	152	40	24	68	23	89.3	82.6	33.3	M20	3/4	UCX15 X15-47 X15-48	FX15	8.0
UCFX16 X16-50	3 1/8	80	214	171	40	24	70	23	91.6	85.7	34.1	M20	3/4	UCX16 X16-50	FX16	9.8
UCFX17 X17-52	3 1/4	85	214	171	40	24	70	23	96.3	96.0	39.7	M20	3/4	UCX17 X17-52	FX17	10.5
UCFX18-56 X18	3 1/2	90	214	171	45	24	76	23	106.1	104.0	42.9	M20	3/4	UCX18-56 X18	FX18	11.2
UCFX20 X20-64	4	100	268	211	59	31	97	31	127.3	117.5	49.2	M27	1	UCX20 X20-64	FX20	18.1

方形座  
Flange Units(Square)

UCF 300 (heavy-duty)

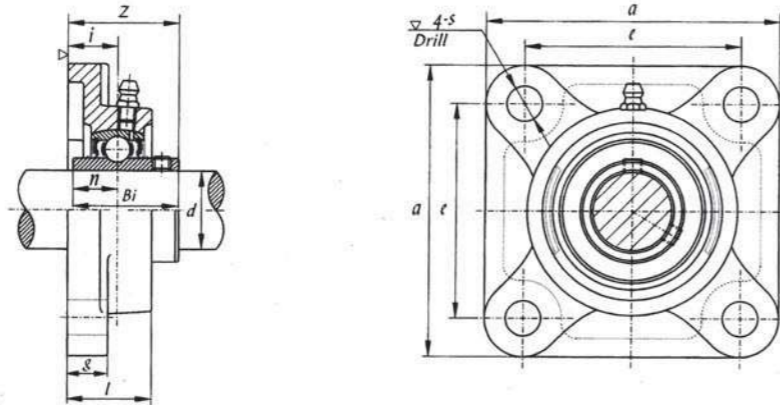

菱形座  
Flange Units (Oval)

UCFL 200 (normal-duty)

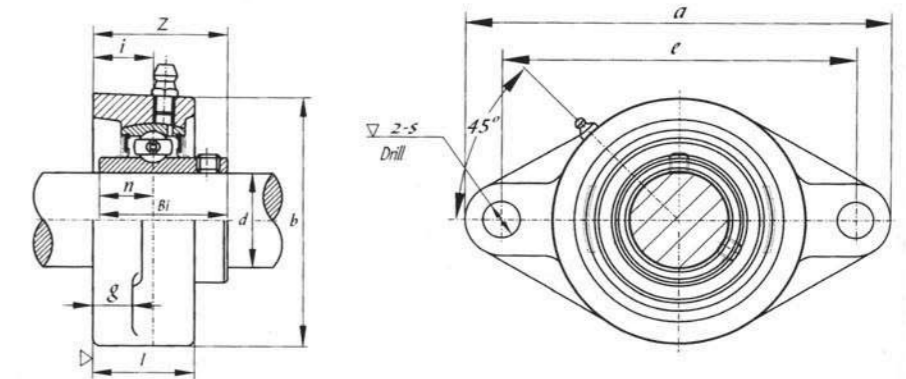

带座轴承代号 Bearing Unit No.	轴 径 Shaft Dia. d		外形尺寸(毫米) Dimensions (mm)									螺 栓 Bolt Used		Bearing No.	Housing No.	重量 Weight (kg)
	(in.)	(mm)	a	e	i	g	l	s	Z	Bi	n	(mm)	(in.)			
UCF305 305-16	1	25	110	80	16	13	29	16	39	38	15	M14	1/2	UC305 305-16	F305	1.20
UCF306-18 306 306-19	1 1/8 1 3/16	30	125	95	18	15	32	16	44	43	17	M14	1/2	UC306-18 306 306-19	F306	1.8
UCF307-20 307-22 307 307-23	1 1/4 1 3/8 1 7/16	35	135	100	20	16	36	19	49	48	19	M16	5/8	UC307-20 307-22 307 307-23	F307	2.20
UCF308-24 308	1 1/2	40	150	112	23	17	40	19	56	52	19	M16	5/8	UC308-24 308	F308	3.0
UCF309-28 309	1 3/4	45	160	125	25	18	44	19	60	57	22	M16	5/8	UC309-28 309	F309	3.8
UCF310-31 310 310-32	1 15/16 2	50	175	132	28	19	48	23	67	61	22	M20	3/4	UC310-31 310 310-32	F310	4.9
UCF311-32 311	2	55	185	140	30	20	52	23	71	66	25	M20	3/4	UC311-32 311	F311	5.6
UCF312 312-36	2 1/4	60	195	150	33	22	56	23	78	71	26	M20	3/4	UC312 312-36	F312	6.8
UCF313-40 313	2 1/2	65	208	166	33	22	58	23	78	75	30	M20	3/4	UC313-40 313	F313	7.8
UCF314-44 314	3/4	70	226	178	36	25	61	25	81	78	33	M22	7/8	UC314-44 314	F314	9.8
UCF315 315-47 315-48	2 15/16 3	75	236	184	39	25	66	25	89	82	32	M22	7/8	UC315 315-47 315-48	F315	11.6
UCF316 316-50	3 1/8	80	250	196	39	27	68	31	91	86	34	M27	1	UC316 316-50	F316	13.2
UCF317		85	260	204	44	27	74	31	100	96	40	M27	1	UC317	F317	15.2
UCF318-56 318	3 1/2	90	280	216	44	30	76	35	100	96	40	M30	1 1/8	UC318-56 318	F318	18.8
UCF319		95	290	228	59	30	94	35	121	103	41	M30	1 1/8	UC319	F319	21.1
UCF320 320-64	4	100	310	242	59	32	94	38	125	108	42	M33	1 1/4	UC320 320-64	F320	25.3
UCF322		110	340	266	60	35	96	41	131	117	46	M36	1 3/8	UC322	F322	35.0
UCF324		120	370	290	65	40	110	41	140	126	51	M36	1 3/8	UC324	F324	47.2
UCF326		130	410	320	65	45	115	41	146	135	54	M36	1 3/8	UC326	F326	64.1
UCF328		140	450	350	75	55	125	41	161	145	59	M36	1 3/8	UC328	F328	90.2

带座轴承代号 Bearing Unit No.	轴 径 Shaft Dia. d		外形尺寸(毫米) Dimensions (mm)											螺 栓 Bolt Used		Bearing No.	Housing No.	重量 Weight (kg)
	(in.)	(mm)	a	e	i	g	l	s	b	z	Bi	n	(mm)	(in.)				
UCFL201 201-8	1/2	12	113	90	15	11	25.5	12	60	33.3	31.0	12.7	M10	3/8	UC201 201-8	FL201	0.44	
UCFL202 202-10	5/8	15	113	90	15	11	25.5	12	60	33.3	31.0	12.7	M10	3/8	UC202 202-10	FL202	0.42	
UCFL203 203-11	11/16	17	113	90	15	11	25.5	12	60	33.3	31.0	12.7	M10	3/8	UC203 203-11	FL203	0.41	
UCFL204-12 204	3/4	20	113	90	15	11	25.5	12	60	33.3	31.0	12.7	M10	3/8	UC204-12 204	FL204	0.39	
UCFL205-14 205-15 205 205-16	7/8 15/16 1	25	130	99	16	13	27	16	68	35.7	34.1	14.3	M14	1/2	UC205-14 205-15 205 205-16	FL205	0.57	
UCFL206-18 206 206-19 206-20	1 1/8 1 3/16 1 1/4	30	148	117	18	13	31	16	80	40.2	38.1	15.9	M14	1/2	UC206-18 206 206-19 206-20	FL206	0.76	
UCFL207-20 207-21 207-22 207 207-23	1 1/4 1 5/16 1 3/8 1 7/16	35	161	130	19	14	34	16	90	44.4	42.9	17.5	M14	1/2	UC207-20 207-21 207-22 207 207-23	FL207	1.05	
UCFL208-24 208-25 208	1 1/2 1 9/16	40	175	144	21	14	36	16	100	51.2	49.2	19.0	M14	1/2	UC208-24 208-25 208	FL208	1.34	
UCFL209-26 209-27 209-28 209	1 5/8 1 11/16 1 3/4	45	188	148	22	15	38	19	108	52.2	49.2	19.0	M16	5/8	UC209-26 209-27 209-28 209	FL209	1.70	
UCFL210-30 210-31 210 210-32	1 7/8 1 15/16 2	50	197	157	22	15	40	19	115	54.6	51.6	19.0	M16	5/8	UC210-30 210-31 210 210-32	FL210	1.92	
UCFL211-32 211-34 211 211-35	2 2 1/8 2 3/16	55	224	184	25	18	43	19	130	58.4	55.6	22.2	M16	5/8	UC211-32 211-34 211 211-35	FL211	2.73	
UCFL212-36 212 212-38 212-39	2 1/4 2 3/8 2 7/16	60	250	202	29	18	48	23	140	68.7	65.1	25.4	M20	3/4	UC212-36 212 212-38 212-39	FL212	3.56	
UCFL213-40 213	2 1/2	65	258	210	30	20	50	23	155	69.7	65.1	25.4	M20	3/4	UC213-40 213	FL213	4.37	
UCFL214-44 214	2 3/4	70	265	216	31	20	54	23	160	75.4	74.6	30.2	M20	3/4	UC214-44 214	FL214	4.95	
UCFL215 215-48	3	75	275	225	34	20	56	23	165	78.5	77.8	33.3	M20	3/4	UC215 215-48	FL215	5.18	
UCFL216 216-50	3 1/8	80	290	233	34	20	58	25	180	83.3	82.6	33.3	M20	3/4	UC216 216-50	FL216	6.36	
UCFL217-52 217	3 1/4	85	305	248	36	22	63	25	190	87.6	85.7	34.1	M20	3/4	UC217-52 217	FL217	7.68	
UCFL218-56 218	3 1/2	90	320	265	40	23	68	25	205	96.3	96	39.7	M20	3/4	UC218-56 218	FL218	9.54	

菱形座  
Flange Units (Oval)

UCFLX00 (medium-duty)

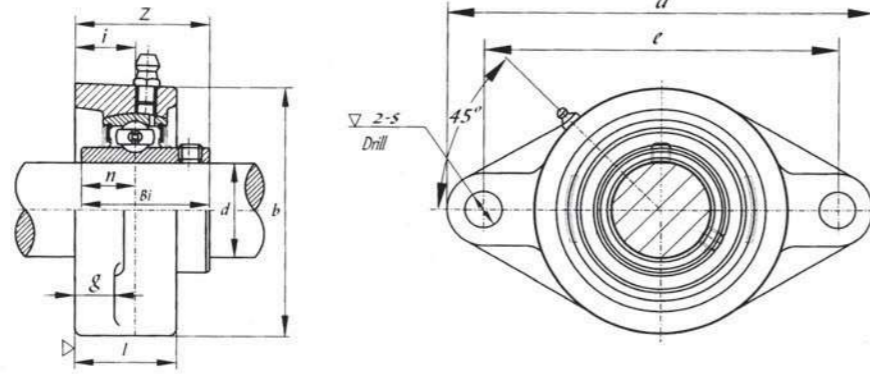

菱形座  
Flange Units (Oval)

UCFL 300 (heavy-duty)

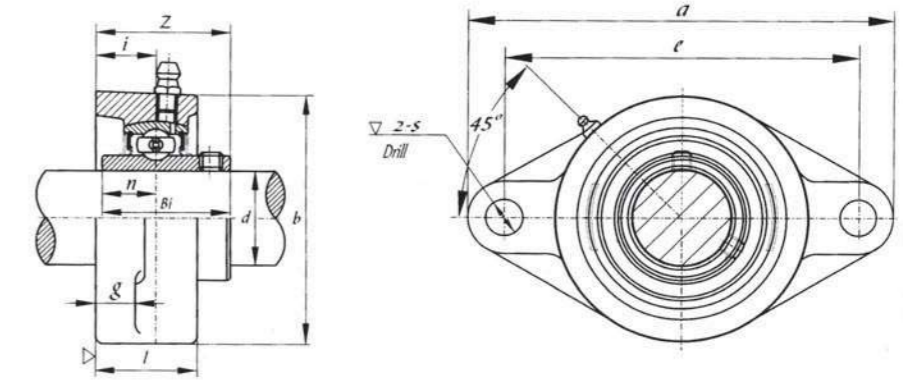

带座轴承代号 Bearing Unit No.	轴径 Shaft Dia.		外形尺寸(毫米) Dimensions (mm)										螺栓 Bolt Used		Bearing No.	Housing No.	重量 Weight (kg)			
	(in.)	(mm)	a	e	i	g	l	s	b	z	Bi	n	(mm)	(in.)						
UCFLX05																				
X05-14	7/8	25	141	117	18	13	30	12	83	40.2	38.1	15.9	M10	3/8	X05-14	FLX05	1.0			
X05-16	1														X05-16					
UCFLX06																				
X06-18	1 1/16	30	155	130	19	14	34	16	95	44.4	42.9	17.5	M14	1/2	X06-18	FLX06	1.4			
X06-19	1 3/16														X06-19					
X06-20	1 1/4														X06-20					
UCFLX07-20	1 1/4																			
X07-22	1 3/8	35	171	144	21	14	38	16	105	51.2	49.2	19.0	M14	1/2	X07-22	FLX07	1.9			
X07															X07					
X07-23	1 7/16														X07-23					
UCFLX08-24	1 1/2	40	179	148	22	14	40	16	111	52.2	49.2	19.0	M14	1/2	X08-24	FLX08	2.0			
X08															X08					
UCFLX09-26	1 5/8																			
X09-27	1 11/16	45	189	157	23	14	40	16	116	55.6	51.6	19.0	M14	1/2	X09-27	FLX09	2.4			
X09-28	1 3/4														X09-28					
X09															X09					
UCFLX10-31	1 15/16																			
X10		50	216	184	26	20	44	19	133	59.4	55.6	22.2	M16	5/8	X10	FLX10	3.7			
X10-32	2														X10-32					

带座轴承代号 Bearing Unit No.	轴径 Shaft Dia.		外形尺寸(毫米) Dimensions (mm)										螺栓 Bolt Used		Bearing No.	Housing No.	重量 Weight (kg)			
	(in.)	(mm)	a	e	i	g	l	s	b	z	Bi	n	(mm)	(in.)						
UCFL305-16	1	25	150	113	16	13	29	19	80	39	38	15	M16	5/8	UC305-16	FL305	1.1			
UCFL306-18	1 1/8	30	180	134	18	15	32	23	90	44	43	17	M20	3/4	UC306-18	FL306	1.5			
UCFL306-20	1 1/4														UC306-20					
UCFL307-20	1 1/4	35	185	141	20	16	36	23	100	49	48	19	M20	3/4	UC307-20	FL307	1.8			
UCFL307-22	1 3/8														UC307-22					
UCFL307-23	1 7/16														UC307-23					
UCFL308-24	1 1/2	40	200	158	23	17	40	23	112	56	52	19	M20	3/4	UC308-24	FL308	2.4			
UCFL308-24															UC308-24					
UCFL309-28	1 3/4	45	230	177	25	18	44	25	125	60	57	22	M22	7/8	UC309-28	FL309	3.4			
UCFL309-28															UC309-28					
UCFL310-31	1 15/16	50	240	187	28	19	48	25	140	67	61	22	M22	7/8	UC310-31	FL310	4.3			
UCFL310-31															UC310-31					
UCFL310-32	2														UC310-32					
UCFL311-32	2	55	250	198	30	20	52	25	150	71	66	25	M22	7/8	UC311-32	FL311	5.2			
UCFL311-32															UC311-32					
UCFL312	2 1/4	60	270	212	33	22	56	31	160	78	71	26	M27	1	UC312-36	FL312	6.3			
UCFL312-36															UC312-36					
UCFL313-40	2 1/2	65	295	240	33	25	58	31	175	78	75	30	M27	1	UC313-40	FL313	7.9			
UCFL313-40															UC313-40					
UCFL314-44	2 3/4	70	315	250	36	28	61	35	185	81	78	33	M30	1 1/8	UC314-44	FL314	9.3			
UCFL314-44															UC314-44					
UCFL315	3	75	320	260	39	30	66	35	195	89	82	32	M30	1 1/8	UC315-48	FL315	10.6			
UCFL315-48															UC315-48					
UCFL316	3 1/8	80	355	285	38	32	68	38	210	90	86	34	M33	1 1/4	UC316-50	FL316	13.5			
UCFL316-50															UC316-50					
UCFL317	3 1/4	85	370	300	44	32	74	38	220	100	96	40	M33	1 1/4	UC317-52	FL317	15.2			
UCFL317-52															UC317-52					
UCFL318-56	3 1/2	90	385	315	44	36	76	38	235	100	96	40	M33	1 1/4	UC318-56	FL318	18.0			
UCFL318-56															UC318-56					
UCFL319		95	405	330	59	40	94	41	250	121	103	41	M36	1 3/8	UC319	FL319	22.7			
UCFL320	4	100	440	360	59	40	94	44	270	125	108	42	M39	1 1/2	UC320-64	FL320	27.2			
UCFL320-64															UC320-64					
UCFL322		110	470	390	60	42	96	44	300	131	117	46	M39	1 1/2	UC322	FL322	34.2			
UCFL324		120	520	430	65	48	110	47	330	140	126	51	M42	1 5/8	UC324	FL324	48.1			
UCFL326		130	550	460	65	50	115	47	360	146	135	54	M42	1 5/8	UC326	FL326	59.5			
UCFL328		140	600	500	75	60	125	51	400	161	145	59	M45	1 3/4	UC328	FL328	73.5			

滑块座  
Take-up Units  
(normal-duty)

UCST 200 (wide inch slot)  
UCT 200 (narrow metric slot)

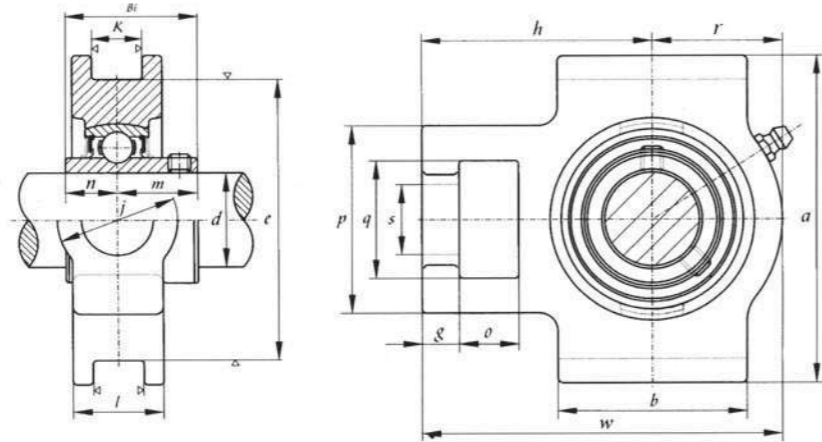

带座轴承代号 Bearing Unit No.	轴径 Shaft Dia. (in.)	外形尺寸(毫米) Dimensions (mm)														Bearing No.	Housing No.	重量 Weight (kg)	
		o	g	p	q	s	b	k	e	a	w	j	l	h	Bi				n
UCST204-12	3/4	5/8	13/32	2	1 1/4	3/4	2	17/32	2 63/64	3 1/2	3 11/16	1 1/4	15/16	2 13/32	1.220	0.500	UC204-12	ST204	1.85
UCST205-14 205-15 205-16	7/8 15/16 1	5/8	13/32	2	1 1/4	3/4	2	17/32	2 63/64	3 1/2	3 11/16	1 1/4	15/16	2 7/16	1.3386	0.563	UC205-14 205-15 205-16	ST205	1.78
UCST206-17 206-18 206-19 206-20	1 1/16 1 1/8 1 3/16 1 1/4	5/8	13/32	2 7/32	1 15/32	55/64	2 1/4	17/32	3 1/2	4 1/32	4 7/16	1 15/32	1 3/32	2 3/4	1.500	0.626	UC206-17 206-18 206-19 206-20	ST206	2.42
UCST207-20 207-21 207-22 207-23	1 1/4 1 5/16 1 3/8 1 7/16	5/8	1/2	2 17/32	1 15/32	55/64	2 17/32	17/32	3 1/2	4 1/32	5 3/32	1 15/32	1 3/16	3 1/16	1.689	0.689	UC207-20 207-21 207-22 207-23	ST207	3.53
UCST208-24 208-25	1 1/2 1 9/16	3/4	5/8	3 9/32	1 15/32	1 9/64	3 9/32	11/16	4 1/64	4 1/2	5 21/32	1 5/16	1 5/16	3 15/32	1.937	0.748	UC208-24 208-25	ST208	5.30
UCST209-26 209-27 209-28	1 5/8 1 11/16 1 3/4	3/4	5/8	3 9/32	1 15/16	1 9/64	3 9/32	11/16	41/64	4 19/32	5 21/32	1 15/16	1 3/8	3 7/16	1.937	0.748	UC209-26 209-27 209-28	ST209	5.30
UCST210-30 210-31 210-32	1 7/8 1 15/16 2	3/4	5/8	3 9/32	1 15/16	1 9/64	3 3/8	11/16	4 1/64	4 19/32	5 7/8	1 15/16	1 15/32	3 17/32	2.031	0.748	UC210-30 210-31 210-32	ST210	5.40
UCST211-32 211-34 211-35	2 2 1/8 2 3/16	1	3/4	4 1/32	2 17/32	1 3/8	3 3/4	1 1/16	5 1/8	5 3/4	6 23/32	2 17/32	1 1/2	4 3/16	2.189	0.874	UC211-32 211-34 211-35	ST211	9.04
UCST212-36 212-38 212-39	2 1/4 2 3/8 2 7/16	1 1/4	3/4	4 1/32	2 17/32	1 3/8	4 1/32	1 1/16	5 1/8	5 3/4	7 5/8	2 17/32	1 21/32	4 11/16	2.563	1.000	UC212-36 212-38 212-39	ST212	11.0
UCST213-40	2 1/2	1 1/4	13/16	4 3/8	2 3/4	1 39/64	4 3/4	1 1/16	5 15/16	6 9/16	8 13/16	2 3/4	1 23/32	5 13/32	2.563	1.000	UC213-40	ST213	15.5

带座轴承代号 Bearing Unit No.	轴径 Shaft Dia. (in.)	外形尺寸(毫米) Dimensions (mm)														Bearing No.	Housing No.	重量 Weight (kg)	
		o	g	p	q	s	b	k	e	a	w	j	l	h	Bi				n
UCT201	12	16	10	51	32	19	51	12	76	89	94	32	21	61	31	12.7	UC201	T204	0.75
UCT202	15	16	10	51	32	19	51	12	76	89	94	32	21	61	31	12.7	UC202	T204	0.73
UCT203	17	16	10	51	32	19	51	12	76	89	94	32	21	61	31	12.7	UC203	T204	0.72
UCT204	20	16	10	51	32	19	51	12	76	89	94	32	21	61	31	12.7	UC204	T204	0.70
UCT205	25	16	10	51	32	19	51	12	76	89	97	32	24	62	34	14.3	UC205	T205	0.73
UCT206	30	16	10	56	37	22	57	12	89	102	113	37	28	70	38.1	15.9	UC206	T206	1.17
UCT207	35	16	13	64	37	22	64	12	89	102	129	37	30	78	42.9	17.5	UC207	T207	1.45
UCT208	40	19	16	83	49	29	83	16	102	114	144	49	33	88	49.2	19	UC208	T208	2.11
UCT209	45	19	16	83	49	29	83	16	102	117	144	49	35	87	49.2	19	UC209	T209	2.18
UCT210	50	19	16	83	49	29	86	16	102	117	149	49	37	90	51.6	19	UC210	T210	2.35
UCT211	55	25	19	102	64	35	95	22	130	146	171	64	38	106	55.6	22.2	UC211	T211	3.56
UCT212	60	32	19	102	64	35	102	22	130	146	194	64	42	119	65.1	25.4	UC212	T212	4.23
UCT213	65	32	21	111	70	41	121	26	151	167	224	70	44	137	65.1	25.4	UC213	T213	6.04
UCT214	70	32	21	111	70	41	121	26	151	167	224	70	46	137	74.6	30.2	UC214	T214	6.35
UCT215	75	32	21	111	70	41	121	26	151	167	232	70	48	140	77.8	33.3	UC215	T215	6.60
UCT216	80	32	21	111	70	41	121	26	165	184	235	70	51	140	82.6	33.3	UC216	T216	7.24
UCT217	85	38	29	124	73	48	157	30	173	198	260	73	54	162	85.7	34.1	UC217	T217	10.33

滑块座  
Take-up Units

UCT 300 (heavy-duty)

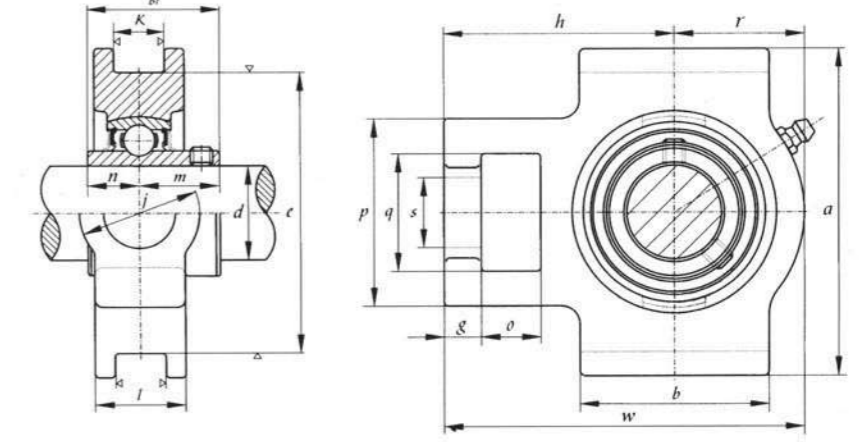

带座轴承代号 Bearing Unit No.	轴径 Shaft Dia. (in.) (mm)	外形尺寸(毫米) Dimensions (mm)																	Bearing No.	Housing No.	重量 Weight (kg)	
		o	g	p	q	i	s	b	k	e	a	w	j	l	r	h	Bi	n				m
UCT305 305-16 305-18	1 1 1/8	25	16	12	62	36	26	65	12	80	89	122	36	26	46	76	38	15	23	UC305 305-16 305-18	T305	1.4
UCT306 306-19	1 3/16	30	18	14	70	41	28	74	16	90	100	137	41	28	52	85	43	17	26	UC306 306-19	T306	1.8
UCT307-20 307-22 307 307-23	1 1/4 1 3/8 1 7/16	35	20	15	75	45	30	80	16	100	111	150	45	32	56	94	48	19	29	UC307-20 307-22 307 307-23	T307	2.3
UCT308-24 308	1 1/2	40	22	17	83	50	32	89	18	112	124	162	50	34	62	100	52	19	33	UC308-24 308	T308	3.0
UCT309-28 309	1 3/4	45	24	18	90	55	34	97	18	125	138	138	55	38	68	110	57	22	35	UC309-28 309	T309	4.1
UCT310-30 310-31 310 310-32	1 7/8 1 15/16 2	50	27	20	98	61	37	106	20	140	151	191	61	40	74	117	61	22	39	UC310-30 310-31 310 310-32	T310	4.9
UCT311-32 311	2	55	29	21	105	66	39	115	22	150	163	207	66	44	80	127	66	25	41	UC311-32 311	T311	6.1
UCT312 312-36	2 1/4	60	31	23	113	71	41	123	22	160	178	220	71	46	85	135	71	26	45	UC312 312-36	T312	7.6
UCT313-40 313	2 1/2	65	32	25	116	70	43	134	26	170	190	238	80	50	92	146	75	30	45	UC313-40 313	T313	9.3
UCT314-44 314	2 3/4	70	36	25	130	85	46	140	26	180	202	252	90	52	97	155	78	33	45	UC314-44 314	T314	11.1
UCT315 315-48	3	75	36	25	132	85	46	150	26	192	216	262	90	55	102	160	82	32	50	UC315 315-48	T315	13
UCT316 316-50	3 1/8	80	42	28	150	98	53	160	30	204	230	282	102	60	108	174	86	34	52	UC316 316-50	T316	16.2
UCT317 317-52	3 1/4	85	42	30	152	98	53	170	32	21	240	298	102	64	115	183	96	40	56	UC317 317-52	T317	19
UCT318-56 318	3 1/2	90	46	30	160	106	57	175	32	228	255	312	110	66	120	192	96	40	56	UC318-56 318	T318	21.6
UCT319		95	46	31	165	106	57	180	35	240	270	322	110	72	125	197	103	41	62	UC319	T319	24.9
UCT320 320-64	4	100	48	32	175	115	59	200	35	260	290	345	120	75	135	210	108	42	66	UC320 320-64	T320	30.7
UCT322		110	52	38	185	125	65	215	38	285	320	385	130	80	150	235	117	46	71	UC322	T322	39.7
UCT324		120	60	42	210	140	70	230	45	320	355	432	140	90	165	267	126	51	75	UC324	T324	54.4
UCT326		130	65	45	220	150	75	240	50	350	385	465	150	100	180	285	135	54	81	UC326	T326	69.3
UCT328		140	70	50	230	160	80	255	50	380	415	515	155	100	200	315	145	59	86	UC328	T328	85.1

凸台圆形座  
Flang Cartridge Units

UCFC 200 (normal-duty)

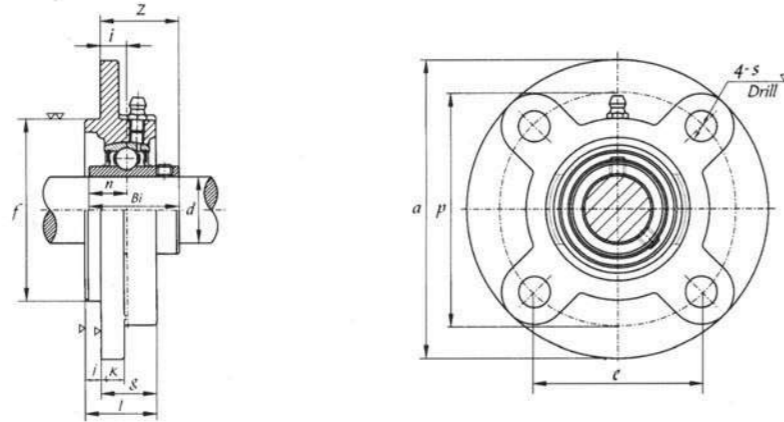

带座轴承代号 Bearing Unit No.	轴径 Shaft Dia.		外形尺寸(毫米) Dimensions (mm)													螺栓 Bolt Used		Bearing No.	Housing No.	重量 Weight (kg)
	(in.)	(mm)	a	p	e	i	l	s	j	k	g	f	z	Bi	n	(mm)	(in.)			
UCFC201 201-8	1/2	12	100	78	55.116	10	25.5	12	5	7	20.5	62	28.3	31.0	12.7	M10	3/8	UC201 201-8	FC201	0.71
UCFC202 202-10	5/8	15	100	78	55.1	10	25.5	12	5	7	20.5	62	28.3	31.0	12.7	M10	3/8	UC202 202-10	FC202	0.69
UCFC203 203-11	11/16	17	100	78	55.1	10	25.5	12	6	7	20.5	62	28.3	31.0	12.7	M10	3/8	UC203 203-11	FC203	0.68
UCFC204-12 204	3/4	20	100	78	55.1	10	25.5	12	6	7	20.5	62	28.3	31.0	12.7	M10	3/8	UC204-12 204	FC204	0.66
UCFC205-14 205-15 205 205-16	7/8 15/16 1	25	115	90	63.6	10	27	12	6	7	21	70	29.7	34.1	14.3	M10	3/8	UC205-14 205-15 205 205-16	FC205	0.92
UCFC206-18 206 206-19 206-20	1 1/8 1 3/16 1 1/4	30	125	100	70.7	10	31	12	8	8	23	80	32.2	38.1	15.9	M10	3/8	UC206-18 206 206-19 206-20	FC206	1.21
UCFC207-20 207-21 207-22 207 207-23	1 1/4 1 5/16 1 3/8 1 7/16	35	135	110	77.8	11	34	14	8	9	26	90	36.4	42.9	17.5	M12	7/16	UC207-20 207-21 207-22 207 207-23	FC207	1.50
UCFC208-24 208-25 208	1 1/2 1 9/16	40	145	120	84.8	11	36	14	10	9	26	100	41.2	49.2	19.0	M12	7/16	UC208-24 208-25 208	FC208	1.87
UCFC209-26 209-27 209-28 209	1 5/8 1 11/16 1 3/4	45	160	132	93.3	10	38	16	12	14	26	105	40.2	49.2	19.0	M14	1/2	UC209-26 209-27 209-28 209	FC209	2.34
UCFC210-30 210-31 210	1 7/8 1 15/16	50	165	138	97.6	10	40	16	12	14	28	110	42.6	51.6	19.0	M14	1/2	UC210-30 210-31 210	FC210	2.72
UCFC211-32 211-34 211 211-35	2 2 1/8 2 3/16	55	185	150	106.1	13	43	19	12	15	31	125	46.4	55.6	22.2	M16	5/8	UC211-32 211-34 211 211-35	FC211	3.66
UCFC212-36 212 212-38 212-39	2 1/4 2 3/8 2 7/16	60	195	160	113.1	17	48	19	12	15	36	135	56.7	65.1	25.4	M16	5/8	UC212-36 212 212-38 212-39	FC212	4.58
UCFC213-40 213	2 1/2	65	205	170	120.0	16	50	19	14	15	36	145	55.7	65.1	25.4	M16	5/8	UC213-40 213	FC213	5.07
UCFC214-44 214	2 3/4	70	215	177	125.1	17	54	19	14	18	40	150	61.4	74.6	30.2	M16	5/8	UC214-44 214	FC214	6.15
UCFC215 215-48	3	75	220	184	130.1	18	56	19	16	18	40	160	62.5	77.8	33.3	M16	5/8	UC215 215-48	FC215	6.79
UCFC216		80	240	200	141.4	18	58	23	16	18	18	170	67.3	82.6	33.3	M20	3/4	UC216	FC216	8.01
UCFC217-52 217	3 1/4	85	250	208	147.1	18	63	23	18	20	45	180	69.6	85.7	34.1	M20	3/4	UC217-52 217	FC217	9.18
UCFC218-56 218	3 1/2	90	265	220	155.5	22	68	23	18	20	50	190	78.3	96.0	39.7	M20	3/4	UC218-56 218	FC218	11.3

高中心立式座  
Pillow Blocks  
(High center height)

UCPH 200 (normal-duty)

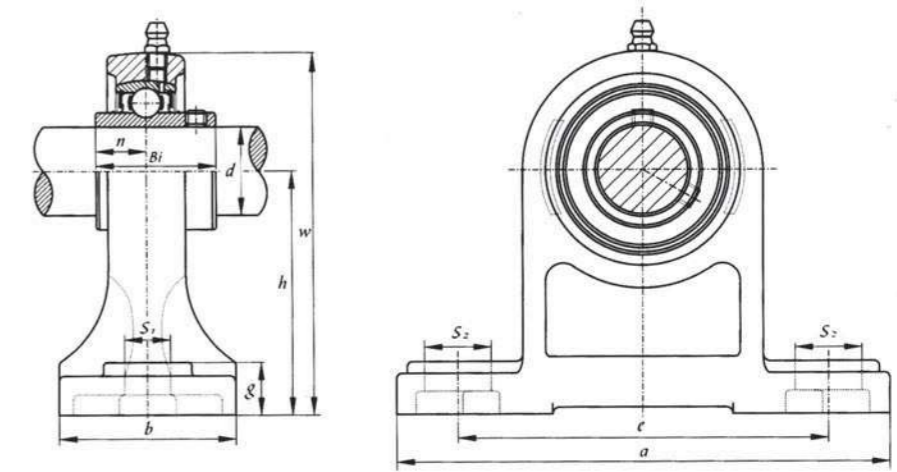

带座轴承代号 Bearing Unit No.	轴径 Shaft Dia.		外形尺寸(毫米) Dimensions (mm)										螺栓 Bolt Used		Bearing No.	Housing No.	重量 Weight (kg)
	(in.)	(mm)	h	a	e	b	s <sub>2</sub>	s <sub>1</sub>	g	w	Bi	n	(mm)	(in.)			
UCPH201 201-8	1/2	12	70	127	95	40	19	13	15	101	31.0	12.7	M10	3/8	UC201 201-8	PH201	0.96
UCPH202 202-10	5/8	15	70	127	95	40	19	13	15	101	31.0	12.7	M10	3/8	UC202 202-10	PH202	0.96
UCPH203 203-11	11/16	17	70	127	95	40	19	13	15	101	31.0	12.7	M10	3/8	UC203 203-11	PH203	0.96
UCPH204-12 204	3/4	20	70	127	95	40	19	13	15	101	31.0	12.7	M10	3/8	UC204-12 204	PH204	0.96
UCPH205-14 205-15 205 205-16	7/8 15/16 1	25	80	140	105	50	19	13	16	114	34.1	14.3	M10	3/8	UC205-14 205-15 205 205-16	PH205	1.2
UCPH206-18 206 206-19 206-20	1 1/8 1 3/16 1 1/4	30	90	165	121	50	21	17	18	130	38.1	15.9	M14	1/2	UC206-18 206 206-19 206-20	PH206	1.6
UCPH207-20 207-21 207-22 207 207-23	1 1/4 1 5/16 1 3/8 1 7/16	35	95	167	127	60	21	17	18	140	42.9	17.5	M14	1/2	UC207-20 207-21 207-22 207 207-23	PH207	2.0
UCPH208-24 208-25 208	1 1/2 1 9/16	40	100	184	137	70	21	17	20	150	49.2	19.0	M14	1/2	UC208-24 208-25 208	PH208	2.7
UCPH209-26 209-27 209-28 209	1 5/8 1 11/16 1 3/4	45	105	190	146	70	21	17	20	158	49.2	19.0	M14	1/2	UC209-26 209-27 209-28 209	PH209	3.0
UCPH210-30 210-31 210 210-32	1 7/8 1 15/16 2	50	110	206	159	70	22	20	22	165	51.6	19.0	M16	5/8	UC210-30 210-31 210 210-32	PH210	3.5

高中心立式座  
Top-based Pillow Blocks

UCPA 200 (normal-duty)

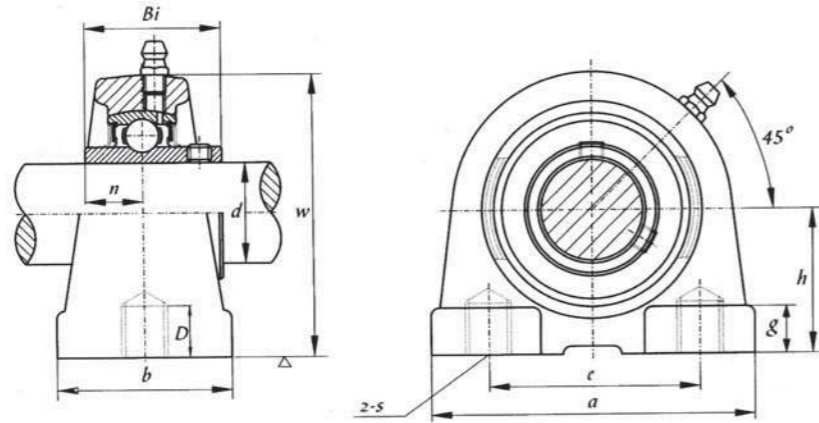

带座轴承代号 Bearing Unit No.	轴径 Shaft Dia. d		外形尺寸(毫米) Dimensions (mm)										螺栓 Bolt size (mm)	Bearing No.	Housing No.	重量 Weight (kg)
	(in.)	(mm)	h	a	e	b	$\frac{s}{mm}$	g	w	D	Bi	n				
UCPA201 201-8	1/2	12	30.2	76	52	40	10	11	62	13	31.0	12.7	M 10	UC201 201-8	PA201	0.56
UCPA202 202-10	5/8	15	30.2	76	52	40	10	11	62	13	31.0	12.7	M 10	UC202 202-10	PA202	0.54
UCPA203 203-11	11/16	17	30.2	76	52	40	10	11	62	13	31.0	12.7	M 10	UC203 203-11	PA203	0.53
UCPA204-12 204	3/4	20	30.2	76	52	40	10	11	62	13	31.0	12.7	M 10	UC204-12 204	PA204	0.51
UCPA205-14 205-15 205 205-16	7/8 15/16 1	25	36.5	84	56	45	10	12	72	13	34.0	14.3	M 10	UC205-14 205-15 205 205-16	PA205	0.68
UCPA206-18 206 206-19	1 1/8 1 3/16	30	42.9	94	66	50	14	12	84	18	38.1	15.9	M 14	UC206-18 206 206-19	PA206	0.99
UCPA207-20 207-21 207-22 207 207-23	1 1/4 1 5/16 1 3/8 1 7/16	35	47.6	110	80	55	14	13	95	20	42.9	17.5	M 14	UC207-20 207-21 207-22 207 207-23	PA207	1.42
UCPA208-24 208-25 208	1 1/2 1 9/16	40	49.2	116	84	58	14	13	100	20	49.2	19.0	M 14	UC208-24 208-25 208	PA208	1.64
UCPA209-26 209-27 209-28 209	1 5/8 1 11/16 1 3/4	45	54.2	120	90	60	14	13	100	25	49.2	19.0	M 14	UC209-26 209-27 209-28 209	PA209	1.80
UCPA210-30 210-31 210 210-32	1 7/8 1 15/16 2	50	57.5	130	94	64	16	14	116	25	51.6	19.0	M 16	UC210-30 210-31 210 210-32	PA210	2.23

可调菱形座  
Adjustable Flange Units

UCFA 200 (normal-duty)

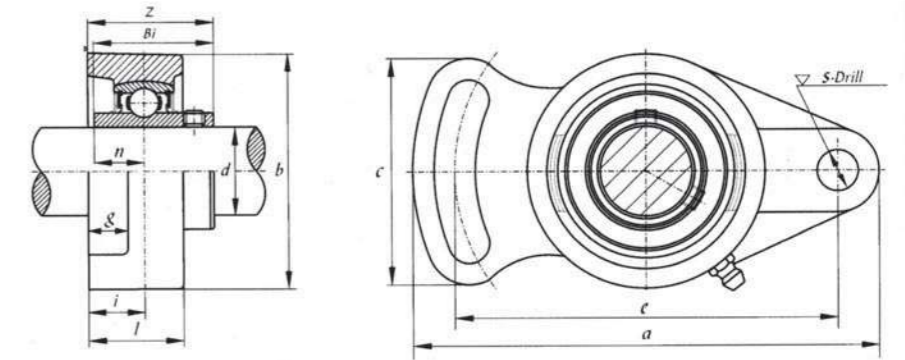

带座轴承代号 Bearing Unit No.	轴径 Shaft Dia. d		外形尺寸(毫米) Dimensions (mm)										螺栓 Bolt Used		Bearing No.	Housing No.	重量 Weight (kg)	
	(in.)	(mm)	a	e	i	g	l	s	b	z	c	Bi	n	(mm)				(in.)
UCFA201 201-8	1/2	12	98	78	15	11	25.5	10	60	33.3	50	31.0	12.7	M8	5/16	UC201 201-8	FA201	0.47
UCFA202 202-10	5/8	15	98	78	15	11	25.5	10	60	33.3	50	31.0	12.7	M8	5/16	UC202 202-10	FA202	0.47
UCFA203 203-11	11/16	17	98	78	15	11	25.5	10	60	33.3	50	31.0	12.7	M8	5/16	UC203 203-11	FA203	0.47
UCFA204-12 204	3/4	20	98	78	15	11	25.5	10	60	33.3	50	31.0	12.7	M8	5/16	UC204-12 204	FA204	0.47
UCFA205-14 205-15 205 205-16	7/8 15/16 1	25	124	98	16.0	13	27	12	70	35.7	65	34.1	14.3	M10	3/8	UC205-14 205-15 205 205-16	FA205	0.68
UCFA206-18 206 206-19 206-20	1 1/8 1 3/16 1 1/4	30	141	117	18	13	31	12	83	40.2	72	38.1	15.9	M10	3/8	UC206-18 206 206-19 206-20	FA206	1.0
UCFA207-20 207-21 207-22 207 207-23	1 1/4 1 5/16 1 3/8 1 7/16	35	155	130	19	14	34	14	96	44.4	82	42.9	17.5	M12	7/16	UC207-20 207-21 207-22 207 207-23	FA207	1.4
UCFA208-24 208-25 208	1 1/2 1 9/16	40	171	144	21	16	36	14	105	51.2	87	49.2	19	M12	7/16	UC208-24 208-25 208	FA208	1.7
UCFA209-26 209-27 209-28 209	1 5/8 1 11/16 1 3/4	45	179	148	22	16	38	16	111	52.2	90	49.2	19	M14	1/2	UC209-26 209-27 209-28 209	FA209	2.1
UCFA210-30 210-31 210 210-32	1 7/8 1 15/16 2	50	189	157	22	16	40	16	116	54.6	94	51.6	19.0	M14	1/2	UC210-30 210-31 210 210-32	FA210	2.4
UCFA211-32 211-34 211 211-35	2 2 1/8 2 3/16	55	216	184	25	16	43	16	133	58.4	104	55.6	22.2	M14	1/2	UC211-32 211-34 211 211-35	FA211	3.4

悬挂式座  
Flange Bracket Units

UCFB 200 (normal-duty)

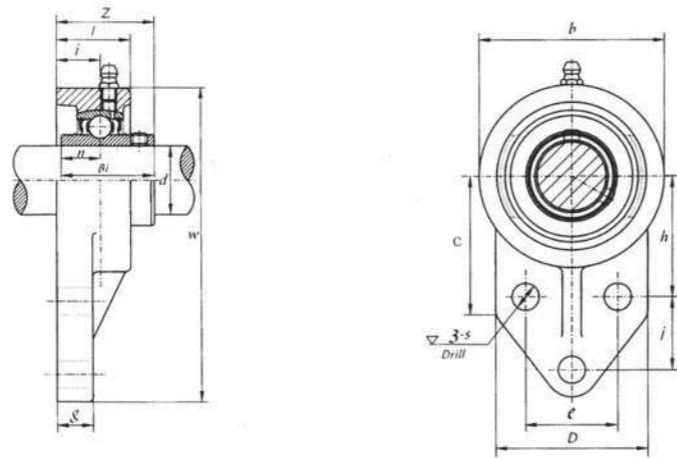

带座轴承代号 Bearing Unit No.	轴 径 Shaft Dia.		外形尺寸(毫米) Dimensions (mm)														螺 栓 Bolt Used		Bearing No.	Housing No.	重量 Weight (kg)
	d	(mm)	w	b	c	D	l	s	g	h	j	e	i	z	Bi	n	(mm)	(in.)			
UCFB201 201-8	1/2	12	110	62	52	52	25.5	10	13	42	27	32	15	31.8	31.0	12.7	M8	5/16	UC201 201-8	FB201	0.64
UCFB202 202-10	5/8	15	110	62	52	52	25.5	10	13	42	27	32	15	31.8	31.0	12.7	M8	5/16	UC202 202-10	FB202	0.64
UCFB203 203-11	11/16	17	110	62	52	52	25.5	10	13	42	27	32	15	31.8	31.0	12.7	M8	5/16	UC203 203-11	FB203	0.64
UCFB204-12 204	3/4	20	110	62	52	52	25.5	10	13	42	27	32	15	31.8	31.0	12.7	M8	5/16	UC204-12 204	FB204	0.64
UCFB205-14 205-15 205	7/8 15/16 1	25	116	68	52	56	27	10	13	45	27	34	16	34.7	34	14.3	M8	5/16	UC205-14 205-15 205	FB205	0.68
UCFB206-18 206	1 1/8	30	132	80	55	65	31	10	13	50	32	40	18	39.2	38.1	15.9	M8	5/16	UC206-18 206	FB206	0.92
UCFB206-19 206-20	1 3/16 2	30	132	80	55	65	31	10	13	50	32	40	18	39.2	38.1	15.9	M8	5/16	UC206-19 206-20	FB206	0.92
UCFB207-20 207-21 207-22 207	1 1/4 1 5/16 1 3/8 1 7/16	35	144	90	62	70	34	10	15	55	32	46	19	44.4	42.9	17.5	M8	5/16	UC207-20 207-21 207-22 207	FB207	1.3
UCFB207-23	1 7/16	35	144	90	62	70	34	10	15	55	32	46	19	44.4	42.9	17.5	M8	5/16	UC207-23	FB207	1.3
UCFB208-24 208-25 208	1 1/2 1 9/16	40	164	100	72	78	36	12	16	60	41	50	21	51.2	49.2	19	M10	3/8	UC208-24 208-25 208	FB208	1.8
UCFB209-26 209-27 209-28 209	1 5/8 1 11/16 1 3/4	45	175	106	76	80	38	12	18	65	43	54	22	52.2	49.2	19	M10	3/8	UC209-26 209-27 209-28 209	FB209	2.0
UCFB210-30 210-31 210	1 7/8 1 15/16	50	184	114	82	86	40	12	18	68	46	58	22	54.6	51.6	19	M10	3/8	UC210-30 210-31 210	FB210	2.3
UCFB210-32	2	50	184	114	82	86	40	12	18	68	46	58	22	54.6	51.6	19	M10	3/8	UC210-32	FB210	2.3

悬吊式座  
Screw Conveyor Hanger Units

UCHA 200 (normal-duty)

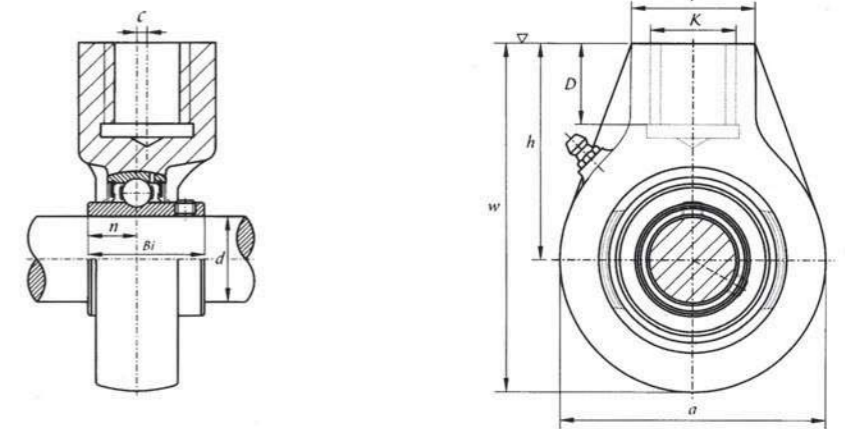

带座轴承代号 Bearing Unit No.	轴 径 Shaft Dia.		外形尺寸(毫米) Dimensions (mm)										Bearing No.	Housing No.	重量 Weight (kg)
	d	(mm)	a	w	c	h	l	D	K	Bi	n				
												(in.)			
UCHA201 201-8	1/2	12	64	96	0	64	40	19	G3/4	31.0	12.7	UC201 201-8	HA201	0.77	
UCHA202 202-10	5/8	15	64	96	0	64	40	19	G3/4	31.0	12.7	UC202 202-10	HA202	0.77	
UCHA203 203-11	11/16	17	64	96	0	64	40	19	G3/4	31.0	12.7	UC203 203-11	HA203	0.77	
UCHA204-12 204	3/4	20	64	96	0	64	40	19	G3/4	31.0	12.7	UC204-12 204	HA204	0.77	
UCHA205-14 205-15 205	7/8 15/16 1	25	78	103	0	64	40	19	G3/4	34	14.3	UC205-14 205-15 205	HA205	0.87	
UCHA206-18 206	1 1/8	30	78	103	0	64	40	19	G3/4	38.1	15.9	UC206-18 206	HA206	0.83	
UCHA206-19 206-20	1 3/16 1 1/4	30	78	103	0	64	40	19	G3/4	38.1	15.9	UC206-19 206-20	HA206	0.83	
UCHA207-20 207-21 207-22 207	1 1/4 1 5/16 1 3/8 1 3/16	35	92	116	0	70	40	19	G3/4	42.9	17.5	UC207-20 207-21 207-22 207	HA207	1.2	
UCHA207-23	1 3/16	35	92	116	0	70	40	19	G3/4	42.9	17.5	UC207-23	HA207	1.2	
UCHA208-24 208-25 208	1 1/2 1 9/16	40	96	121	2	73	40	19	G3/4	49.2	19.0	UC208-24 208-25 208	HA208	1.3	
UCHA209-26 209-27 209-28 209	1 5/8 1 11/16 1 3/4	45	108	136	5	82	48	21	G1	49.2	19	UC209-26 209-27 209-28 209	HA209	1.7	
UCHA210-30 210-31 210	1 7/8 1 15/16 2	50	118	142	5	83	48	21	G1	51.6	19.0	UC210-30 210-31 210	HA210	2.1	
UCHA210-32	2	50	118	142	5	83	48	21	G1	51.6	19.0	UC210-32	HA210	2.1	
UCHA211-32 211-34 211	2 2 1/8 2 3/16	55	126	150	7	95	60	25	G1 1/4	55.6	22.2	UC211-32 211-34 211	HA211	2.8	
UCHA211-35	2 3/16	55	126	150	7	95	60	25	G1 1/4	55.6	22.2	UC211-35	HA211	2.8	
UCHA212-36 212	2 1/4	60	142	173	9	102	60	28	G1 1/4	65.1	25.4	UC212-36 212	HA212	3.9	
UCHA212-38 212-39	2 3/8 2 7/16	60	142	173	9	102	60	28	G1 1/4	65.1	25.4	UC212-38 212-39	HA212	3.9	
UCHA213-40 213	2 1/2	65	166	200	9.5	117	70	32	G1 1/2	65.1	25.4	UC213-40 213	HA213	5.8	
UCHA214-44 214	2 3/4	70	166	200	9.5	117	70	32	G1 1/2	74.6	30.2	UC214-44 214	HA214	5.9	
UCHA215 215-47 215-48	2 15/16 3	75	166	200	9.5	117	70	32	G1 1/2	77.8	33.3	UC215 215-47 215-48	HA215	5.6	

环形座  
Cartridge Units

UCC 200 (normal-duty)

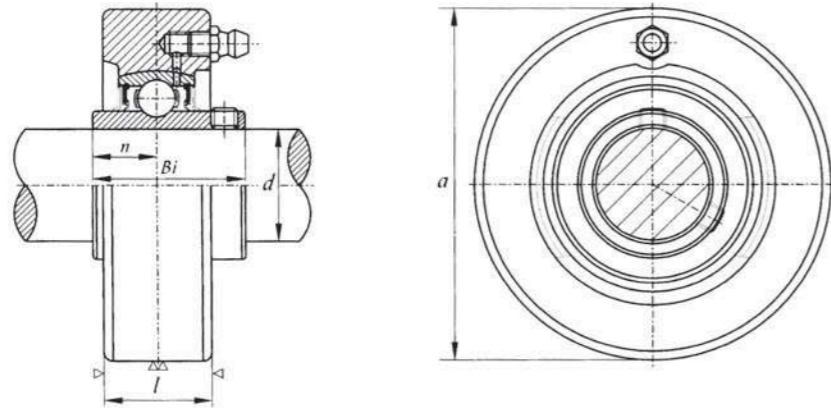

带座轴承代号 Bearing Unit No.	轴 径 Shaft Dia.		外形尺寸(毫米) Dimensions (mm)				Bearing No.	Housing No.	重量 Weight (kg)
	(in.)	(mm)	a	l	Bi	n			
UCC201 201-8	1/2	12	72	20	31.0	12.7	UC201 201-8	C201	0.50
UCC202 202-10	5/8	15	72	20	31.0	12.7	UC202 202-10	C202	0.50
UCC203 203-11	1 1/16	17	72	20	31.0	12.7	UC203 203-11	C203	0.50
UCC204-12 204	3/4	20	72	20	31.0	12.7	UC204-12 204	C204	0.50
UCC205-14 205-15 205	7/8 1 5/16	25	80	22	34	14.3	UC205-14 205-15 205	C205	0.64
UCC205-16 205-16	1						205-16		
UCC206-18 206	1 1/8						UC206-18 206		
206-19 206-20	1 3/16 1 1/4	30	85	27	38.1	15.9	206-19 206-20	C206	0.81
UCC207-20 207-21 207-22 207	1 1/4 1 5/16 1 3/8	35	90	28	42.9	17.5	UC207-20 207-21 207-22 207	C207	0.93
207-23	1 7/16						207-23		
UCC208-24 208-25 208	1 1/2 1 9/16	40	100	30	49.2	19	UC208-24 208-25 208	C208	1.2
UCC209-26 209-27 209-28 209	1 5/8 1 11/16 1 3/4	45	110	31	49.2	19	UC209-26 209-27 209-28 209	C209	1.5
UCC210-30 210-31 210	1 7/8 1 15/16	50	120	33	51.6	19	UC210-30 210-31 210	C210	2.0
210-32	2						210-32		
UCC211-32 211-34 211	2 2 1/8	55	125	35	55.6	22.2	UC211-32 211-34 211	C211	2.2
211-35	2 3/16						211-35		
UCC212-36 212	2 1/4	60	130	38	65.1	25.4	UC212-36 212	C212	2.6
212-38 212-39	2 3/8 2 7/16						212-38 212-39		
UCC213-40 213	2 1/2	65	140	40	65.1	25.4	UC213-40 213	C213	3.0

冲压立式座 Pressed Housing Pillow Blocks (light-duty)

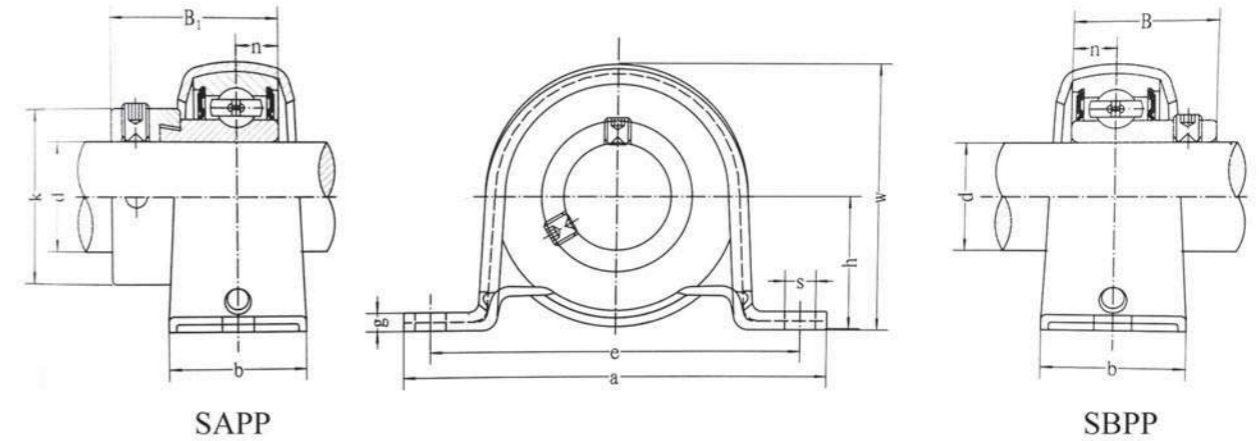

带座轴承 型号	名义尺寸(mm)										螺栓 规格	轴承 型号	轴承座 型号	重量 (kg)
	d	h	a	e	b	s	g	w	B1	n				
SAPP201	12	22.2	86	68	25	9.5	3.2	43.8	28.6	6.5	M8	SA201	PP201	0.19
SAPP202	15	22.2	86	68	25	9.5	3.2	43.8	28.6	6.5	M8	SA202	PP202	0.18
SAPP203	17	22.2	86	68	25	9.5	3.2	43.8	28.6	6.5	M8	SA203	PP203	0.17
SAPP204	20	25.4	98	76	32	9.5	3.2	50.5	31.0	7.5	M8	SA204	PP204	0.25
SAPP205	25	28.6	108	86	32	11.5	4.0	56.6	31.0	7.5	M10	SA205	PP205	0.32
SAPP206	30	33.3	117	95	38	11.5	4.0	66.3	35.7	9.0	M10	SA206	PP206	0.47
SAPP207	35	39.7	129	106	42	11.5	4.6	78.0	38.9	9.5	M10	SA207	PP207	0.76
SAPP208	40	43.7	148	120	43	13.0	5.0	86.2	43.7	11.0	M12	SA208	PP208	0.92

带座轴承 型号	名义尺寸(mm)										螺栓 规格	轴承 型号	轴承座 型号	重量 (kg)
	d	h	a	e	b	s	g	w	B	n				
SBPP201	12	22.2	86	68	25	9.5	3.2	43.8	22	6.0	M8	SB201	PP201	0.16
SBPP202	15	22.2	86	68	25	9.5	3.2	43.8	22	6.0	M8	SB202	PP202	0.15
SBPP203	17	22.2	86	68	25	9.5	3.2	43.8	22	6.0	M8	SB203	PP203	0.14
SBPP204	20	25.4	98	76	32	9.5	3.2	50.5	25	7.0	M8	SB204	PP204	0.22
SBPP205	25	28.6	108	86	32	11.5	4.0	56.6	27	7.5	M10	SB205	PP205	0.28
SBPP206	30	33.3	117	95	38	11.5	4.0	66.3	30	8.0	M10	SB206	PP206	0.42
SBPP207	35	39.7	129	106	42	11.5	4.6	78.0	32	8.5	M10	SB207	PP207	0.63
SBPP208	40	43.7	148	120	43	13.0	5.0	86.2	34	9.0	M12	SB208	PP208	0.76

带冲压菱形座外球面轴承

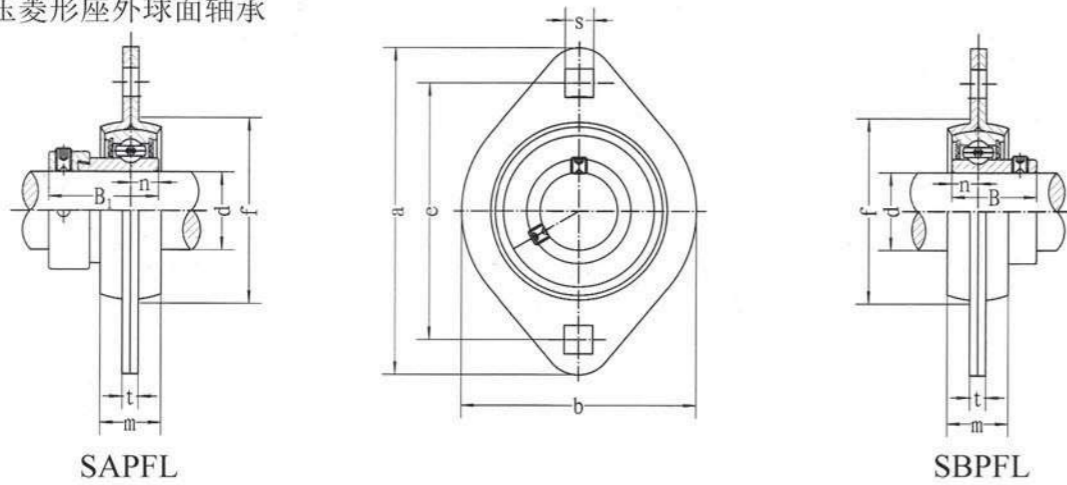

SAPFL

SBPFL

带座轴承 型号	名义尺寸(mm)										螺栓 规格	轴承 型号	轴承座 型号	重量 (kg)
	d	a	e	b	m	s	t	f(min)	B1	n				
SAPFL201	12	81	63.5	59	14	7.1	4.0	49	28.6	6.5	M6	SA201	PFL201	0.20
SAPFL202	15	81	63.5	59	14	7.1	4.0	49	28.6	6.5	M6	SA202	PFL202	0.19
SAPFL203	17	81	63.5	59	14	7.1	4.0	49	28.6	6.5	M6	SA203	PFL203	0.18
SAPFL204	20	90	71.5	67	16	9.0	4.0	56	31.0	7.5	M8	SA204	PFL204	0.25
SAPFL205	25	95	76.0	71	18	9.0	4.0	60	31.0	7.5	M8	SA205	PFL205	0.29
SAPFL206	30	113	90.5	84	18	11.0	5.2	71	35.7	9.0	M10	SA206	PFL206	0.46
SAPFL207	35	122	100.0	94	20	11.0	5.2	81	38.9	9.5	M10	SA207	PFL207	0.67
SAPFL208	40	148	119.0	100	21	13.5	6.8	91	43.7	11.0	M12	SA208	PFL208	0.91

带座轴承 型号	名义尺寸(mm)										螺栓 规格	轴承 型号	轴承座 型号	重量 (kg)
	d	a	e	b	m	s	t	f(min)	B	n				
SBPFL201	12	81	63.5	59	14	7.1	4.0	49	22	6.0	M6	SB201	PFL201	0.18
SBPFL202	15	81	63.5	59	14	7.1	4.0	49	22	6.0	M6	SB202	PFL202	0.17
SBPFL203	17	81	63.5	59	14	7.1	4.0	49	22	6.0	M6	SB203	PFL203	0.16
SBPFL204	20	90	71.5	67	16	9.0	4.0	56	25	7.0	M8	SB204	PFL204	0.22
SBPFL205	25	95	76.0	71	18	9.0	4.0	60	27	7.5	M8	SB205	PFL205	0.25
SBPFL206	30	113	90.5	84	18	11.0	5.2	71	30	8.0	M10	SB206	PFL206	0.40
SBPFL207	35	122	100.0	94	20	11.0	5.2	81	32	8.5	M10	SB207	PFL207	0.53
SBPFL208	40	148	119.0	100	21	13.5	6.8	91	34	9.0	M12	SB208	PFL208	0.75

带冲压圆形座外球面轴承

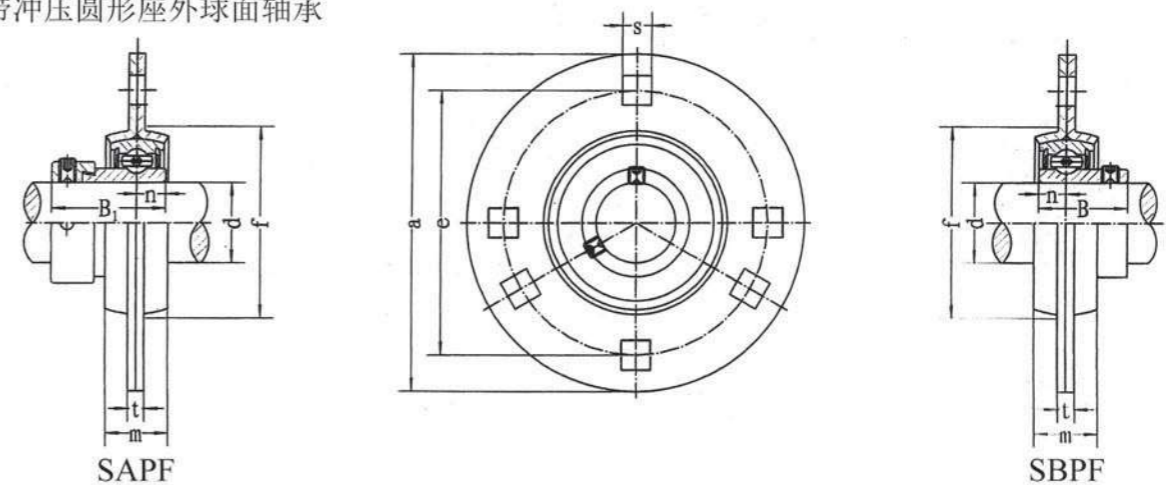

SAPF

SBPF

带座轴承 型号	名义尺寸(mm)										螺栓 规格	轴承 型号	轴承座 型号	重量 (kg)
	d	a	e	m	S <sup>1)</sup>	t	f(min)	B1	n					
SAPF201	12	81	63.5	14	7.1	4.0	49	28.6	6.5	M6	SA201	PF201	0.31	
SAPF202	15	81	63.5	14	7.1	4.0	49	28.6	6.5	M6	SA202	PF202	0.30	
SAPF203	17	81	63.5	14	7.1	4.0	49	28.6	6.5	M6	SA203	PF203	0.29	
SAPF204	20	90	71.5	16	9.0	4.0	56	31.0	7.5	M8	SA204	PF204	0.32	
SAPF205	25	95	76.0	18	9.0	4.0	60	31.0	7.5	M8	SA205	PF205	0.37	
SAPF206	30	113	90.5	18	11.0	5.2	71	35.7	9.0	M10	SA206	PF206	0.59	
SAPF207	35	122	100.0	20	11.0	5.2	81	38.9	9.5	M10	SA207	PF207	0.81	
SAPF208	40	148	119.0	21	13.5	6.8	91	43.7	11.0	M12	SA208	PF208	1.30	

带座轴承 型号	名义尺寸(mm)										螺栓 规格	轴承 型号	轴承座 型号	重量 (kg)
	d	a	e	m	S <sup>1)</sup>	t	f(min)	B	n					
SBPF201	12	81	63.5	14	7.1	4.0	49	22	6.0	M6	SB201	PF201	0.28	
SBPF202	15	81	63.5	14	7.1	4.0	49	22	6.0	M6	SB202	PF202	0.27	
SBPF203	17	81	63.5	14	7.1	4.0	49	22	6.0	M6	SB203	PF203	0.26	
SBPF204	20	90	71.5	16	9.0	4.0	56	25	7.0	M8	SB204	PF204	0.29	
SBPF205	25	95	76.0	18	9.0	4.0	60	27	7.5	M8	SB205	PF205	0.33	
SBPF206	30	113	90.5	18	11.0	5.2	71	30	8.0	M10	SB206	PF206	0.54	
SBPF207	35	122	100.0	20	11.0	5.2	81	32	8.5	M10	SB207	PF207	0.68	
SBPF208	40	148	119.0	21	13.5	6.8	91	34	9.0	M12	SB208	PF208	1.14	

带冲压三角形座外球面轴承

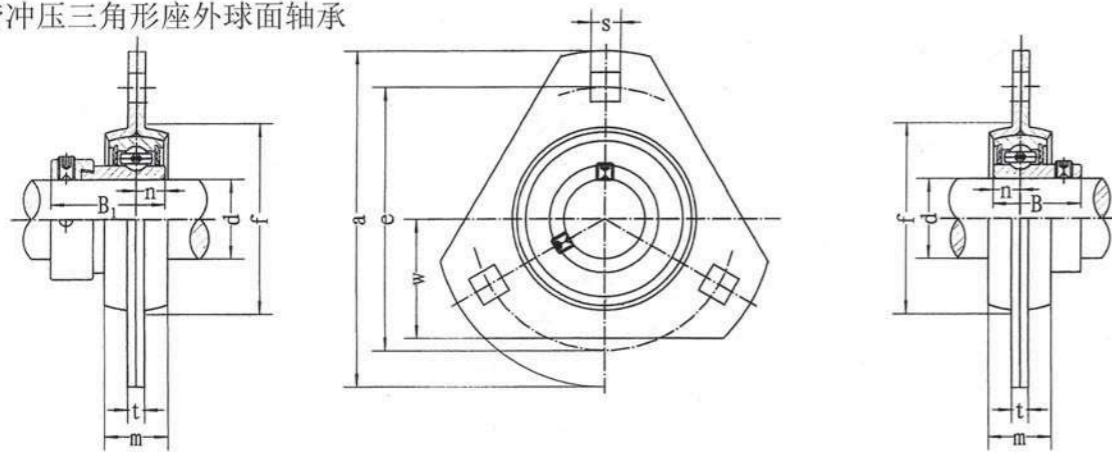

SAPFT

SBPFT

带座轴承 型号	名义尺寸(mm)										螺栓 规格	轴承 型号	轴承座 型号	重量 (kg)
	d	a	e	w	m	s	t	f(min)	B1	n				
SAPFT201	12	81	63.5	28.5	14	7.1	4.0	49	28.6	6.5	M6	SA201	PFT201	0.21
SAPFT202	15	81	63.5	28.5	14	7.1	4.0	49	28.6	6.5	M6	SA202	PFT202	0.20
SAPFT203	17	81	63.5	28.5	14	7.1	4.0	49	28.6	6.5	M6	SA203	PFT203	0.19
SAPFT204	20	90	71.5	33.0	16	9.0	4.0	56	31.0	7.5	M8	SA204	PFT204	0.28
SAPFT205	25	95	76.0	35.0	18	9.0	4.0	60	31.0	7.5	M8	SA205	PFT205	0.32
SAPFT206	30	113	90.5	40.0	18	11.0	5.2	71	35.7	9.0	M10	SA206	PFT206	0.50
SAPFT207	35	122	100.0	44.5	20	11.0	5.2	81	38.9	9.5	M10	SA207	PFT207	0.71

带座轴承 型号	名义尺寸(mm)										螺栓 规格	轴承 型号	轴承座 型号	重量 (kg)
	d	a	e	w	m	s	t	f(min)	B	n				
SBPFT201	12	81	63.5	28.5	14	7.1	4.0	49	22	6.0	M6	SB201	PFT201	0.19
SBPFT202	15	81	63.5	28.5	14	7.1	4.0	49	22	6.0	M6	SB202	PFT202	0.18
SBPFT203	17	81	63.5	28.5	14	7.1	4.0	49	22	6.0	M6	SB203	PFT203	0.17
SBPFT204	20	90	71.5	33.0	16	9.0	4.0	56	25	7.0	M8	SB204	PFT204	0.24
SBPFT205	25	95	76.0	35.0	18	9.0	4.0	60	27	7.5	M8	SB205	PFT205	0.28
SBPFT206	30	113	90.5	40.0	18	11.0	5.2	71	30	8.0	M10	SB206	PFT206	0.44
SBPFT207	35	122	100.0	44.5	20	11.0	5.2	81	32	8.5	M10	SB207	PFT207	0.58

带顶丝外球面球轴承  
Ball Bearing  
(with setscrews)

UC 200 (normal-duty)

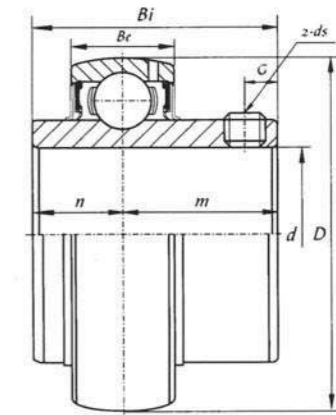

轴承代号 Bearing No.	轴径 Shaft Dia.		外形尺寸(毫米) Dimensions (mm)							额定动负荷 Basic Dynamic Load Rating (N)	额定静负荷 Basic Static Load Rating (N)	重量 Weight (kg)
	d (in.)	d (mm)	D	Bi	Be	n	m	G	ds			
UC201 201-8	1/2	12	47	31.0	16	12.7	18.3	5	M6X1.0	12800	6650	0.2 0.19
UC202 202-10	5/8	15	47	31.0	16	12.7	18.3	5	M6X1.0	12800	6650	0.18 0.18
UC203 203-11	11/16	17	47	31.0	16	12.7	18.3	5	M6X1.0	12800	6650	0.17
UC204-12 204	3/4	20	47	31.0	16	12.7	18.3	5	M6X1.0	12800	6650	0.16 0.15
UC205-14 205-15 205	7/8 15/16	25	52	34.1	17	14.3	19.8	5.5	M6X1.0	14000	7880	0.22 0.20 0.19 0.19
UC206-18 206	1 1/8	30	62	38.1	19	15.9	22.2	6	M6X1.0	14500	11200	0.32 0.3 0.3
UC206-19 206-20	1 3/16 1 1/4	30	62	38.1	19	15.9	22.2	6	M6X1.0	14500	11200	0.32 0.3 0.3
UC207-20 207-21 207-22 207	1 1/4 1 5/16 1 3/8	35	72	42.9	20	17.5	25.4	6.5	M8X1.0	25700	15200	0.50 0.48 0.45 0.45 0.42
UC207-23	1 7/16	35	72	42.9	20	17.5	25.4	6.5	M8X1.0	25700	15200	0.50 0.48 0.45 0.45 0.42
UC208-24 208-25 208	1 1/2 1 9/16	40	80	49.2	21	19	30.2	8	M8X1.0	29600	18200	0.64 0.6 0.59
UC209-26 209-27 209-28 209	1 5/8 1 11/16 1 3/4	45	85	49.2	22	19	30.2	8	M8X1.0	31850	20800	0.74 0.71 0.68 0.65
UC210-30 210-31 210	1 7/8 1 15/16	50	90	51.6	23	19	32.6	10	M10X1.0	35100	23200	0.85 0.76 0.74 0.71
UC210-32	2	50	90	51.6	23	19	32.6	10	M10X1.0	35100	23200	0.85 0.76 0.74 0.71
UC211-32 211-34 211	2 2 1/8	55	100	55.6	25	22.2	33.4	10	M10X1.0	43550	29200	1.10 1.01 0.96 0.93
UC211-35	2 3/16	55	100	55.6	25	22.2	33.4	10	M10X1.0	43550	29200	1.10 1.01 0.96 0.93
UC212-36 212	2 1/4	60	110	65.1	27	25.4	39.7	10	M10X1.0	47800	32800	1.51 1.38 1.37 1.27
UC212-38 212-39	2 3/8 2 7/16	60	110	65.1	27	25.4	39.7	10	M10X1.0	47800	32800	1.51 1.38 1.37 1.27
UC213-40 213	2 1/2	65	120	65.1	28	25.4	39.7	10	M10X1.0	57200	40000	1.75 1.67
UC214-44 214	2 3/4	70	125	74.6	29	30.2	44.4	12	M12X1.5	60800	45000	1.95 1.95
UC215 215-47 215-48	2 15/16 3	75	130	77.8	30	33.3	44.5	12	M12X1.5	66000	49500	2.14 2.17 2.16
UC216 216-50	3 1/8	80	140	82.6	33	33.3	49.3	12	M12X1.5	71500	54200	2.61
UC217-52 217	3 1/4	85	150	85.7	35	34.1	51.6	12	M12X1.5	83200	63800	3.38
UC218-56 218	3 1/2	90	160	96.0	37	39.7	56.3	12	M12X1.5	95900	71500	4.1 4.0
UC220		100	180	108	40	42	66	12	M12X1.5	122000	92800	6.1

带顶丝外球面球轴承  
Ball Bearings  
(with setscrews)

UCX00 (medium-duty)

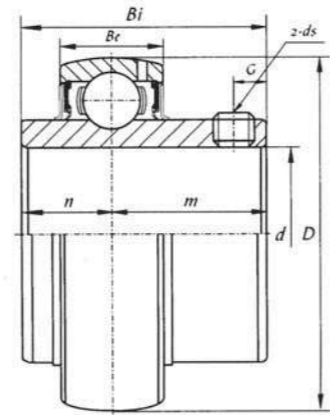

轴承代号 Bearing No.	轴 径 Shaft Dia.		外形尺寸(毫米) Dimensions (mm)							额定动负荷 Basic Dynamic Load Rating (N)	额定静负荷 Basic Static Load Rating (N)	重 量 Weight (kg)
	d		D	Bi	Be	n	m	G	ds			
	(in.)	(mm)										
UCX05 X05-16	1	25	62	38.1	19	15.9	22.2	6.0	M6X1.0	19500	11200	0.37
UCX06 X06-19 X06-20	1 3/16 1 1/4	30	72	42.9	20	17.5	25.4	6.5	M8X1.0	25700	15200	0.54
UCX07-20 X07-22 X07	1 1/4 1 3/8	35	80	49.2	21	19.0	30.2	8.0	M8X1.0	29600	18200	0.71
UCX08-24 X08	1 1/2	40	85	49.2	22	19.0	30.2	8.0	M8X1.0	31800	20800	0.79
UCX09-27 X09-28 X09	1 11/16 1 3/4	45	90	51.6	23	19.0	32.6	10	M10X1.0	35100	23200	0.92
UCX10-31 X10 X10-32	1 15/16 2	50	100	55.6	25	22.2	33.4	10	M10X1.0	43500	29200	1.20
UCX11 X11-32 X11-35 X11-36	2 2 3/16 2 1/4	55	110	65.1	27	25.4	39.7	10	M10X1.0	47800	32800	1.63
UCX12 X12-36 X12-38 X12-39	2 2 3/8 2 7/16	60	120	65.1	28	25.4	39.7	10	M10X1.0	57200	40000	1.95
UCX13-40 X13	2 1/2	65	125	74.6	29	30.2	44.4	12.0	M12X1.5	60800	45000	2.32
UCX14-44 X14	2 3/4	70	130	77.8	30	33.3	44.5	12.0	M12X1.5	66000	49500	2.53
UCX15 X15-47 X15-48	2 15/16 3	75	140	82.6	33	33.3	49.3	12.0	M12X1.5	71500	54200	3.06
UCX16 X16-50	3 1/8	80	150	85.7	35	34.1	51.6	12.0	M12X1.5	83200	63800	3.61
UCX17 X17-52	3 1/4	85	160	96.0	37	39.7	56.3	12.0	M12X1.5	95900	71500	4.55
UCX18-56 X18	3 1/2	90	170	104.0	39	42.9	61.1	16.0	M14X1.5	109000	82800	5.42
UCX20 X20-64	4	100	190	117.5	43	49.2	68.3	18.0	M16X1.5	133000	105000	7.6

带顶丝外球面球轴承  
Ball Bearings  
(with setscrews)

UC 300 (heavy-duty)

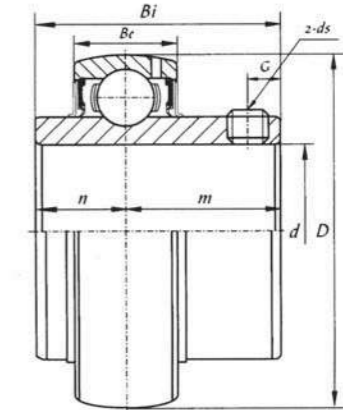

轴承代号 Bearing No.	轴 径 Shaft Dia.		外形尺寸(毫米) Dimensions (mm)							额定动负荷 Basic Dynamic Load Rating (N)	额定静负荷 Basic Static Load Rating (N)	重 量 Weight (kg)
	d		D	Bi	Be	n	m	G	ds			
	(in.)	(mm)										
UC305 305-16	1	25	62	38	20	15	23	6	M6X1.0	22400	11500	0.34
UC306-18 306 306-20	1 1/18 1 1/4	30	72	43	23	17	26	6	M6X1.0	26500	15200	0.52
UC307-20 307-22 307	1 1/4 1 3/8	35	80	48	25	19	29	8	M8X1.0	33300	19200	0.68
UC308-24 308	1 1/2	40	90	52	27	19	33	10	M10X1.0	40600	23700	0.95
UC309-28 309	1 3/4	45	100	57	30	22	35	10	M10X1.0	48600	28900	1.22
UC310-31 310 310-32	1 15/16 2	50	110	61	32	22	39	12	M12X1.5	61700	37800	1.57
UC311-32 311	2	55	120	66	34	25	41	12	M12X1.5	71500	44800	1.98
UC312 312-36	2 1/4	60	130	71	36	26	45	12	M12X1.5	81600	51800	2.45
UC313-40 313	2 1/2	65	140	75	38	30	45	12	M12X1.5	93700	60400	3.14
UC314-44 314	2 3/4	70	150	78	40	33	45	12	M12X1.5	103600	67100	3.62
UC315 315-48	3	75	160	82	42	32	50	14	M14X1.5	112800	75700	4.50
UC316 316-50	3 1/8	80	170	86	44	34	52	14	M14X1.5	123500	88200	5.2
UC317 317-52	3 1/4	85	180	96	46	40	56	16	M16X1.5	133000	96500	6.63
UC318-56 318	3 1/2	90	190	96	48	40	56	16	M16X1.5	144700	110600	7.33
UC319		95	200	103	50	41	62	16	M16X1.5	156600	122000	8.37
UC320 320-64	4	100	215	108	54	42	66	18	M16X1.5	171600	141000	10.32
UC322		110	240	117	60	46	71	18	M18X1.5	205000	179000	14.2
UC324		120	260	126	64	51	75	18	M18X1.5	227000	207000	18.20
UC326		130	280	135	68	54	81	20	M20X1.5	253000	241000	22.50
UC328		140	300	145	72	59	86	20	M20X1.5	274000	272000	29.4

带偏心套外球面球轴承  
Ball Bearings  
(with eccentric locking collar)

HC 200 (normal-duty)

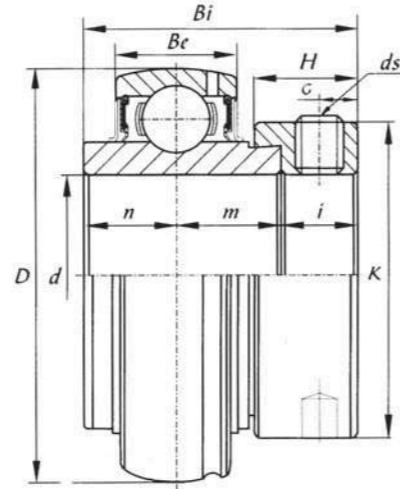

轴承代号 Bearing No.	轴径 Shaft Dia.		外形尺寸(毫米) Dimensions (mm)										额定动负荷 Basic Dynamic Load Rating (N)	额定静负荷 Basic Static Load Rating (N)	重量 Weight (kg)
	(in.)	(mm)	D	Bi	Be	n	m	i	k	H	G	ds			
HC203 203-11	11/16	17	47	43.7	16	17.0	17.0	9.5	33.3	13.5	5.0	M6X1	12800	6650	0.25
HC204-12 204	3/4	20	47	43.7	16	17.0	17.0	9.5	33.3	13.5	5.0	M6X1	12800	6650	0.23 0.22
HC205-14 205-15 205	7/8 15/16	25	52	44.4	17	17.4	17.4	9.5	38.1	13.5	5.0	M6X1	14000	7880	0.29 0.27 0.25 0.25
HC206-18 206 206-19 206-20	1 1/8 1 3/16 1 1/4	30	62	48.4	19	18.3	18.2	11.9	44.5	15.9	6.0	M8X1	19500	11200	0.43 0.41 0.41 0.38
HC207-20 207-22 207 207-23	1 1/4 1 3/8 1 7/16	35	72	51.1	20	18.8	18.8	13.5	55.6	17.5	6.5	M8X1	25700	15200	0.68 0.61 0.61 0.58
HC208-24 208	1 1/2	40	80	56.3	21	21.4	21.4	13.5	60.3	18.3	6.5	M8X1	29600	18200	0.83 0.79 0.78
HC209-26 209-27 209-28 209	1 5/8 1 11/16 1 3/4	45	85	56.3	22	21.4	21.4	13.5	63.5	18.3	6.5	M8X1	31850	20800	0.96 0.91 0.87 0.85
HC210-31 210 210-32	1 15/16 2	50	90	62.7	23	24.6	24.6	13.5	69.9	18.3	6.5	M8X1	35100	23200	1.04 1.01
HC211-32 211 211-35	2 2 3/16	55	100	71.4	25	27.7	27.7	15.9	76.2	20.7	8.0	M10X1	43550	29200	1.58 1.39 1.36
HC212-36 212 212-39	2 1/4 2 7/16	60	110	77.8	27	30.9	30.9	15.9	84.2	22.3	8.0	M10X1	47800	32800	2.03 1.87 1.76
HC213-40 213	2 1/2	65	120	85.7	28	34.1	34.1	17.1	86	23.5	8.5	M10X1	57200	40000	2.51
HC215-47 215 215-48	2 15/16 3	75	130	92.1	30	37.3	37.3	17.1	102	23.5	8.5	M10X1	60800	45000	2.74

带圆锥孔外球面球轴承  
UK Ball Bearings  
(with tapered bore)

UK 200 (normal-duty)

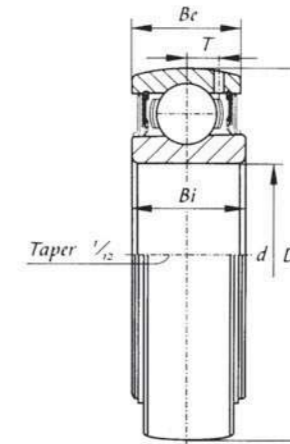

轴承代号 Bearing No.	轴径 Shaft Dia.	外形尺寸(毫米) Dimensions (mm)					额定动负荷 Basic Dynamic Load Rating (N)	额定静负荷 Basic Static Load Rating (N)	重量 Weight (kg)
		d (mm)	D	Bi	Be	Bi (TRL)			
UK205	25	52	25	17	24	4.2	14000	7850	0.16
UK206	30	62	28	19	27	5.2	19450	11250	0.25
UK207	35	72	30	20	30	5.6	25700	15200	0.36
UK208	40	80	32	21	34	6.2	29600	18100	0.44
UK209	45	85	33	22	36	6.3	31850	20800	0.51
UK210	50	90	35	23	36	6.5	35100	23200	0.56
UK211	55	100	37	25	40	7.0	43550	29200	0.74
UK212	60	110	40	27	47	7.0	47800	32800	1.00
UK213	65	120	42	30	47	8.5	57200	40000	1.27
UK215	75	130	45	32	51	9.2	66000	49500	1.52
UK216	80	140	45	33	55	9.6	71500	53300	1.84
UK217	85	150	47	35	57	10.5	83200	63800	2.34
UK218	90	160	50	37	63	11.1	95900	71500	2.85

带止动环深沟球轴承  
Ball Bearings  
(with locating snap ring)

SER 200 (normal-duty)

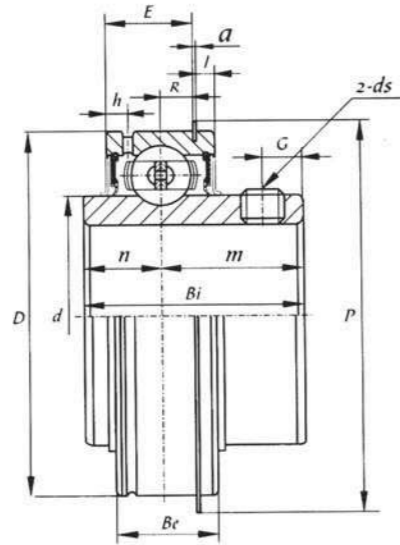

轴承代号 Bearing No.	轴径 Shaft Dia. d		外形尺寸(毫米) Dimensions (mm)													额定动负荷 Basic Dynamic Load Rating (kg)	额定静负荷 Basic Static Load Rating (kg)	重量 Weight (kg)
	(in.)	(mm)	D	Bi	Be	n	m	E	a	h	R	J	P	G	ds			
SER201 201-8	1/2	12	47	31.0	15.9	11.5	19.5	12.09	1.07	4.0	4.14	2.46	52.7	5.0	M6X1.0	1010	630	0.22
SER202 202-10	5/8	15	47	31.0	15.9	11.5	19.5	12.09	1.07	4.0	4.14	2.46	52.7	5.0	M6X1.0	1010	630	0.22
SER203 203-11	11/16	17	47	31.0	15.9	11.5	19.5	12.09	1.07	4.0	4.14	2.46	52.7	5.0	M6X1.0	1010	630	0.22
SER204-12 204	3/4	20	47	31.0	15.9	11.5	19.5	12.09	1.07	4.0	4.14	2.46	52.7	5.0	M6X1.0	1010	630	0.21
SER205-14 205-15 205	7/8 15/16	25	52	34.9	19.1	13.1	21.8	15.29	1.07	5.2	5.74	2.46	57.9	5.6	M6X1.0	1100	710	0.27
SER205-16 205-16	1																	
SER206-18 206	1 1/8																	
206-19 206-19	1 3/16	30	62	38.1	22.2	15.9	22.2	17.02	1.65	5.6	5.92	3.28	67.7	5.6	M6X1.0	1530	1020	0.39
206-20 206-20	1 1/4																	
SER207-20 207-22 207	1 1/4 1 3/8	35	72	42.9	23.8	17.5	25.4	18.62	1.65	5.6	6.72	3.28	78.6	6.4	M8X1.0	2020	1390	0.56
207-23 207-23	1 7/16																	
SER208-24 208	1 1/2	40	80	49.2	27.8	19.0	30.2	22.62	1.65	6.4	8.72	3.28	86.6	8.0	M8X1.0	2280	1590	0.72
SER209-26 209-27 209-28 209	1 5/8 1 11/16 1 3/4	45	85	49.2	27.8	19.0	30.2	22.62	1.65	6.4	8.72	3.28	91.6	8.0	M8X1.0	2560	1810	0.90
SER210-30 210-31 210	1 7/8 1 15/16	50	90	51.6	28.6	19.0	32.6	22.62	2.41	7.5	8.32	3.28	96.5	9.5	M10X1.0	2750	2020	0.93
210-32 210-32	2																	
SER211-32 211	2	55	100	55.6	30.2	22.2	33.4	24.22	2.41	7.5	9.12	3.28	106.5	9.5	M10X1.0	3400	2550	1.29
211-35 211-35	2 3/16																	
SER212-36 212	2 1/4	60	110	65.1	31.8	25.4	39.7	25.82	2.41	7.5	9.92	3.28	116.6	11.1	M10X1.0	4100	3150	1.71
212-39 212-39	2 7/16																	

带偏心套球轴承  
Ball Bearings  
(with eccentric collar)

SA 200 (light-duty)  
Spherical O.D.

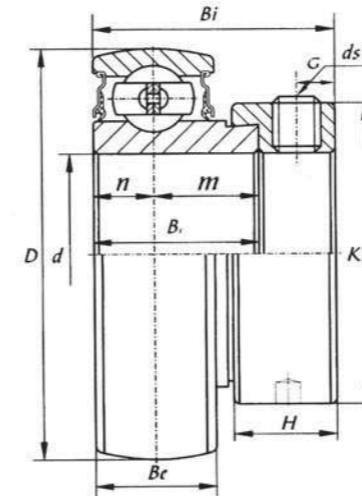

CSA 200 (light-duty)  
Cylindrical O.D.

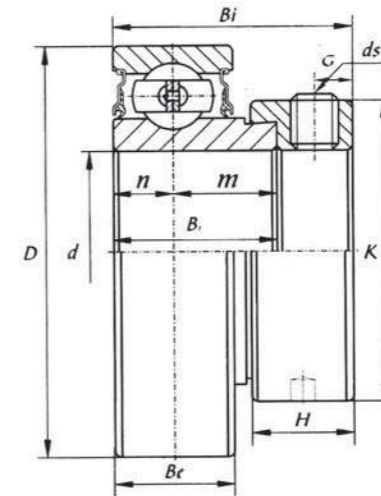

SA 200G  
Relubricatable type

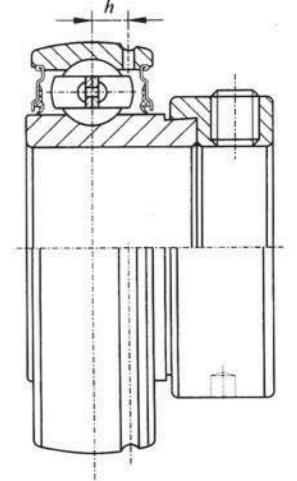

轴承代号 Bearing No.	轴径 Shaft Dia. d		外形尺寸(毫米) Dimensions (mm)											额定动负荷 Basic Dynamic Load Rating (N)	额定静负荷 Basic Static Load Rating (N)	重量 Weight (kg)	
	(in.)	(mm)	Be	D	B1	n	m	Bi	K	H	G	h	ds				
SA201 201-8	1/2	12	12	40	19.1	6.0	13.1	28.6	28.6	13.5	5.0	3.6	M6X1.0	9600	4600	0.13	
SA202 202-10	5/8	15	12	40	19.1	6.0	13.1	28.6	28.6	13.5	5.0	3.6	M6X1.0	9600	4600	0.12	
SA203 203-11	11/16	17	12	40	19.1	6.0	13.1	28.6	28.6	13.5	5.0	3.6	M6X1.0	9600	4600	0.10	
SA204-12 204	3/4	20	14	47	21.5	7.5	14.5	31.0	33.3	13.5	5.0	4	M6X1.0	12800	6650	0.16	
SA205-14 205	7/8	25	15	52	21.5	7.5	14	31.0	38.1	13.5	5.0	4.3	M6X1.0	14000	7880	0.19	
205-16 205-16	1																
SA206-18 206	1 1/8																
206-19 206-19	1 3/16	30	16	62	23.8	9.0	14.8	35.7	44.5	15.9	6.0	5	M8X1.0	19500	11200	0.30	
206-20 206-20	1 1/4																
SA207-20 207-22 207	1 1/4 1 3/8	35	17	72	25.4	9.5	15.9	38.9	55.6	17.5	6.5	5.7	M8X1.0	25700	15200	0.45	
207-23 207-23	1 7/16																
SA208-24 208-25 208	1 1/2 1 9/16	40	18	80	30.2	11	19.2	43.7	60.3	18.3	6.5	6.2	M8X1.0	29600	18200	0.60	
SA209-26 209-27 209-28 209	1 5/8 1 11/16 1 3/4	45	19	85	30.2	11	19.2	43.7	63.5	18.3	6.5	6.8	M8X1.0	31850	20800	0.64	
SA210-30 210-31 210	1 7/8 1 15/16	50	20	90	30.2	11	19.2	43.7	69.9	18.3	6.5	6.5	M8X1.0	35100	23200	0.71	
SA211-32 211-34 211	2 2 1/8	55	21	100	32.5	12	20.5	48.4	76.2	20.7	8	7.2	M10X1.0	43550	29200	0.87	
211-35 211-35	2 3/16																
SA212-36 212 212-38 212-39	2 1/4 2 3/8 2 7/16	60	22	110	37.2	13.5	21.4	53.1	84.2	22.3	8	8	M10X1.0	47800	32800	1.3	

带偏心套球轴承  
Ball Bearings  
(with eccentric collar)

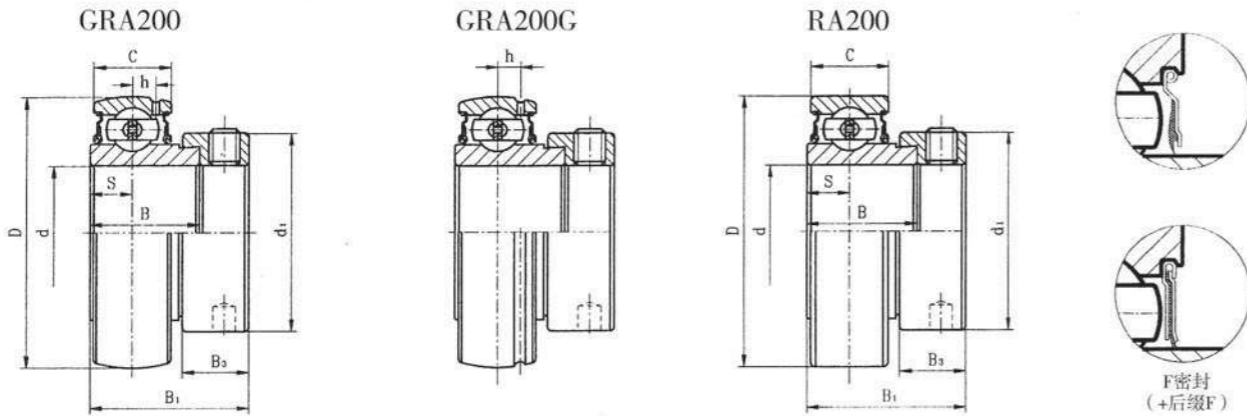

轴承代号	轴径		外形尺寸 (mm)								基本额定载荷 (N)		重量 (kg)
	d		D	C	h	S	B <sub>1</sub>	B	B <sub>2</sub>	d <sub>1</sub>	动载荷 C <sub>r</sub>	静载荷 C <sub>or</sub>	
	(in.)	(mm)											
GRA201 RA201-8 202 202-10 203 203-11	1/2 5/8 11/16	12 15 17	40	12	3.6	6.5	28.6	19.1	13.5	28.6	9550	4780	0.14 0.14 0.13 0.13 0.13
GRA204-12 RA204	3/4	20	47	14	4	7.5	30.9	21.4	13.5	33.3	12800	6560	0.18 0.15
GRA205-14 205-15 205 205-16	7/8 15/16 1	25	52	15	4.3	7.5	30.9	21.4	13.5	38.1	14000	7880	0.22 0.21 0.19 0.18
GRA206-18 RA206 206-19 206-20	1-1/8 1-3/16 1-1/4	30	62	18	5	9	35.7	23.8	15.9	44.5	19500	11200	0.35 0.33 0.31 0.29
GRA207-20 RA207-21 207-22 207 207-23	1-1/4 1-5/16 1-3/8 1-7/16	35	72	19	5.7	9.5	38.9	25.4	17.5	55.6	25700	15200	0.56 0.53 0.51 0.50 0.48
GRA208-24 RA208-25 208	1-1/2 1-9/16	40	80	21	6.2	11	43.7	30.2	18.3	60.3	29600	18200	0.68 0.67 0.65
GRA209-26 RA209-27 209-28 209	1-5/8 1-11/16 1-3/4	45	85	22	6.8	11	43.7	30.2	18.3	63.5	31850	20800	0.82 0.76 0.73 0.69
GRA210-30 RA210-31 210	1-7/8 1-15/16	50	90	22	6.5	11	43.7	30.2	18.3	69.9	35100	23200	0.85 0.83 0.79
GRA211-32 RA211-34 211 211-35	2 2-1/8 2-3/16	55	100	24	7.2	12	32.5	32.5	20.7	76.2	43550	29200	1.18 0.96 0.87 0.81
GRA212-36 RA212 212-38 212-39	2-1/4 2-7/8 2-7/16	60	110	24	8	13.5	37.5	37.5	22.3	84.2	47800	32800	1.35

带顶丝球轴承  
Ball Bearings  
(with setscrews)

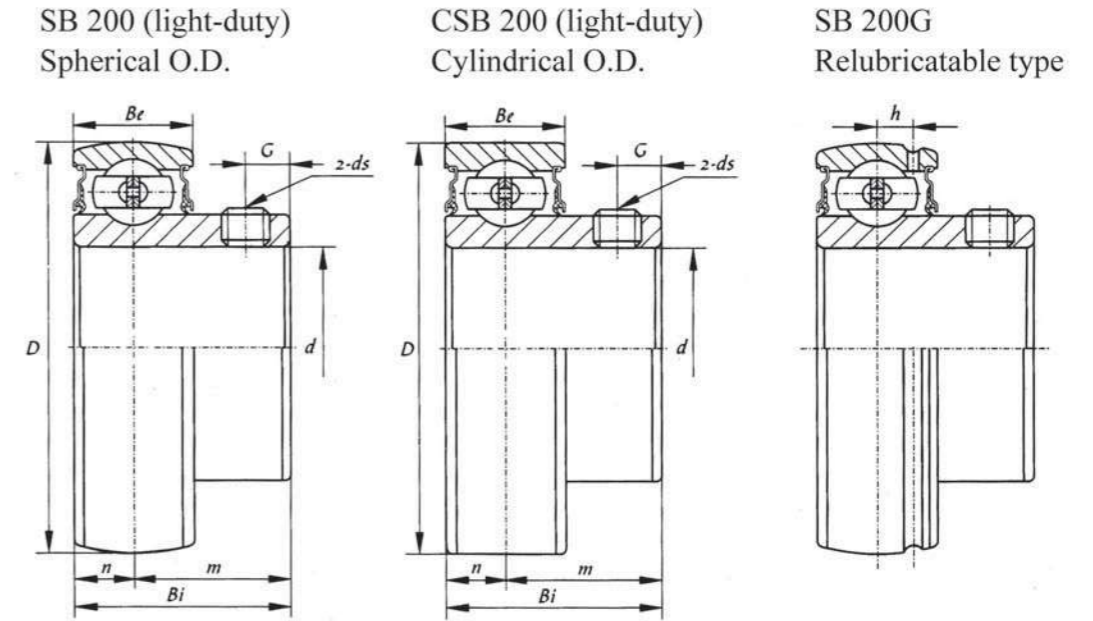

轴承代号 Bearing No.	轴径 Shaft Dia.		外形尺寸 (毫米) Dimensions (mm)							额定动负荷 Basic Dynamic Load Rating (N)	额定静负荷 Basic Static Load Rating (N)	重量 Weight (kg)	
	d		Be	D	Bi	n	m	G	h				ds
	(in.)	(mm)											
SB201 201-18	1/2	12	12	40	22	6.0	16.0	4.5	3.6	M5X0.8	9600	4600	0.10
SB202 202-10	5/8	15	12	40	22	6.0	16.0	4.5	3.6	M5X0.8	9600	4600	0.09
SB203 203-11	11/16	17	12	40	22	6.0	16.0	4.5	3.6	M5X0.8	9600	4600	0.08
SB204-12 204	3/4	20	14	47	25	7.0	18.0	4.5	3.9	M6X1.0	12800	6650	0.12
SB205-14 205 205-16	7/8 1	25	15	52	27	7.5	19.5	5.5	3.9	M6X1.0	14000	7880	0.16
SB206-18 206 206-19 206-20	1 1/8 1 3/16 1 1/4	30	16	62	30	8.0	22.0	6.0	5.0	M6X1.0	19500	11200	0.25
SB207-20 207-22 207 207-23	1 1/4 1 3/8 1 7/16	35	17	72	32	8.5	23.5	6.5	5.5	M8X1.0	25700	15200	0.36
SB208-24 208	1 1/2	40	18	80	34	9.0	25.0	7.0	6.0	M8X1.0	29600	18200	0.45
SB209-26 209-27 209 209-28	1 5/8 1 11/16 1 3/4	45	19	85	41.2	10.2	31.0	8.2	6.3	M8X1.0	31850	20800	0.56
SB210-30 210-31 210 210-32	1 7/8 1 13/16 2	50	20	90	43.5	10.9	32.6	9.2	6.5	M8X1.0	35100	23200	0.62
SB211-32 211-34 211 211-35	2 2 1/8 2 3/16	55	21	100	45.3	11.8	33.5	9.8	7.2	M8X1.0	43550	29200	1.1
SB212 212-36	2 1/4	60	22	110	53.7	14.9	38.8	9.8	8	M10X1.0	47800	32800	1.3

农机轴承  
AGRI-BEARING  
SQUARE BORE WITHOUT GREASE NIPPLE

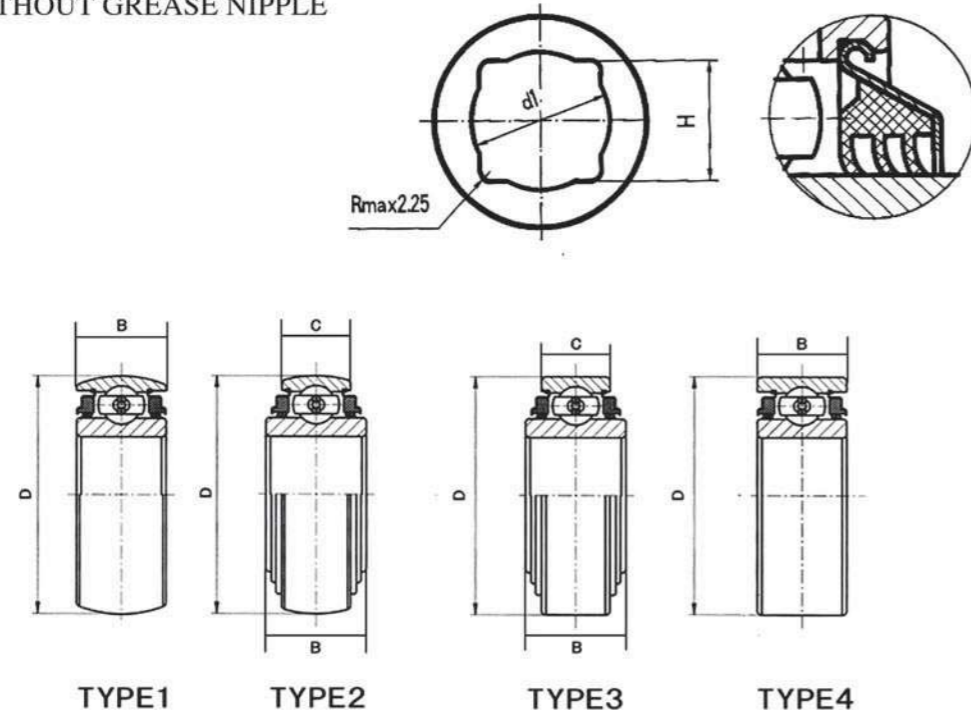

轴承代号 Bearing No.	型号 Type	外形尺寸(毫米) Dimensions (mm)					额定动负荷 Basic Load Rating CR (KN)	额定静负荷 Basic Statie Load Rating COR (KN)	重量 Weight (KG)
		H	d1	D	C	B			
W208PPB13	1	22.970	24.000	80.000	18.00	36.53	22.71	15.94	0.690
W208PPB6	1	26.000	28.000	80.000	18.00	36.53	22.71	15.94	0.652
W208PP6	3	26.000	32.000	80.000	18.00	36.53	22.71	15.94	0.662
W208PPB5	1	29.970	32.000	80.000	18.00	36.53	22.71	15.94	0.590
W208PPB8	1	29.970	32.000	80.000	30.18	36.53	22.71	15.94	0.735
W208PP5	3	29.970	32.000	80.000	18.00	36.53	22.71	15.94	0.600
W208PP20	3	29.970	32.000	80.000	18.00	36.53	22.71	15.94	0.681
W208PP8	3	29.970	32.000	80.000	30.18	36.53	22.71	15.94	0.709
W209PPB5	1	33.000	32.000	85.000	30.18	36.53	24.36	17.11	0.945
W210PP4	4	29.970	32.000	100.000	30.18	30.18	27.50	20.20	1.049
W210PPB6	1	29.970	32.000	90.000	30.18	36.53	27.50	20.20	0.733
W210PPB4	2	29.970	32.000	90.000	30.18	30.18	27.50	20.20	0.846
W211PPB3	2	38.890	42.000	100.000	33.34	33.34	33.40	25.10	1.208
W211PP3	4	38.890	42.000	100.000	33.34	33.34	33.40	25.10	1.271
W211PP5	3	38.890	42.000	101.600	44.45	44.45	33.40	25.10	1.302
20414	3	30.1	31	80	18	36.53	25.09	19.82	0.652

深沟球轴承  
Deep Groove Ball Bearing

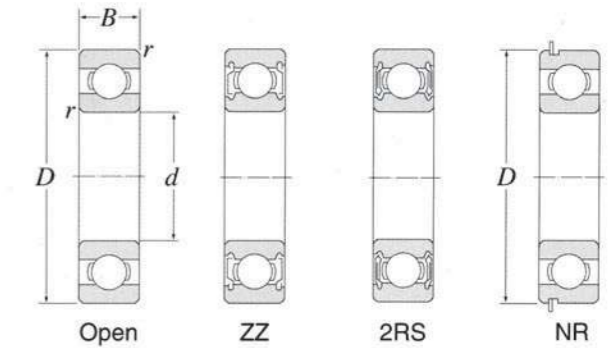

型号 Bearing No.				主要尺寸 Boundary dimensions (mm)				基本负荷 Basic load ratings (KN)		重量 Weight
OPEN	ZZ	2RS	NR	d	D	B	rsmin	Cr	Cor	kg
6000	ZZ	2RS	NR	10	26	8	0.3	4.55	1.96	0.019
6001	ZZ	2RS	NR	12	28	8	0.3	5.10	2.39	0.021
6002	ZZ	2RS	NR	15	32	9	0.3	5.60	2.84	0.030
6003	ZZ	2RS	NR	17	35	10	0.3	6.80	3.35	0.039
6004	ZZ	2RS	NR	20	42	12	0.6	9.40	5.05	0.069
6005	ZZ	2RS	NR	25	47	12	0.6	10.10	5.85	0.080
6006	ZZ	2RS	NR	30	55	13	1	13.20	8.30	0.116
6007	ZZ	2RS	NR	35	62	14	1	16.0	10.3	0.155
6008	ZZ	2RS	NR	40	68	15	1	16.8	11.5	0.190
6009	ZZ	2RS	NR	45	75	16	1	21.0	15.1	0.237
6010	ZZ	2RS	NR	50	80	16	1	21.8	16.6	0.261
6011	ZZ	2RS	NR	55	90	18	1.1	28.3	21.2	0.388
6012	ZZ	2RS	NR	60	95	18	1.1	29.5	23.2	0.414
6013	ZZ	2RS	NR	65	100	18	1.1	30.5	25.2	0.421
6014	ZZ	2RS	NR	70	110	20	1.1	38.0	31.0	0.604
6015	ZZ	2RS	NR	75	115	20	1.1	39.5	33.5	0.649
6016	ZZ	2RS	NR	80	125	22	1.1	47.5	40.0	0.854
6017	ZZ	2RS	NR	85	130	22	1.1	49.5	43.0	0.890
6018	ZZ	2RS	NR	90	140	24	1.5	58.0	49.5	1.02
6019	ZZ	2RS	NR	95	145	24	1.5	60.5	54.0	1.08
6020	ZZ	2RS	NR	100	150	24	1.5	60.0	54.0	1.15
6021	ZZ	2RS	NR	105	160	26	2	72.5	65.5	1.59
6022	ZZ	2RS	NR	110	170	28	2	82.0	73.0	1.96
6024	ZZ	2RS	NR	120	180	28	2	85.0	79.5	2.07
6026	ZZ	2RS	NR	130	200	33	2	106.0	101.0	3.16
6028	ZZ	2RS	NR	140	210	33	2	110.0	109.0	3.35
6200	ZZ	2RS	NR	10	30	9	0.6	5.1	2.39	0.032
6201	ZZ	2RS	NR	12	32	10	0.6	6.1	2.75	0.037
6202	ZZ	2RS	NR	15	35	11	0.6	7.75	3.60	0.045
6203	ZZ	2RS	NR	17	40	12	0.6	9.60	4.60	0.066
6204	ZZ	2RS	NR	20	47	14	1	12.80	6.65	0.106
6205	ZZ	2RS	NR	25	52	15	1	14.0	7.85	0.128
6206	ZZ	2RS	NR	30	62	16	1	19.5	11.3	0.199
6207	ZZ	2RS	NR	35	72	17	1.1	25.7	15.3	0.288
6208	ZZ	2RS	NR	40	80	18	1.1	29.1	17.8	0.366
6209	ZZ	2RS	NR	45	85	19	1.1	32.5	20.4	0.398
6210	ZZ	2RS	NR	50	90	20	1.1	35.0	23.2	0.454
6211	ZZ	2RS	NR	55	100	21	1.5	43.5	29.2	0.601
6212	ZZ	2RS	NR	60	110	22	1.5	52.5	36.0	0.783
6213	ZZ	2RS	NR	65	120	23	1.5	57.5	40.0	0.990
6214	ZZ	2RS	NR	70	125	24	1.5	62.0	44.0	1.07
6215	ZZ	2RS	NR	75	130	25	1.5	66.0	49.5	1.18
6216	ZZ	2RS	NR	80	140	26	2	72.5	53.0	1.40
6217	ZZ	2RS	NR	85	150	28	2	83.5	64.0	1.79

型号 OPEN	型号 ZZ 2RS NR			主要尺寸 Boundary dimensions (mm)				基本负荷 Basic load ratings (kN)		重量 kg
	ZZ	2RS	NR	d	D	B	rsmin	Cr	Cor	
6218	ZZ	2RS	NR	90	160	30	2	96.0	71.5	2.15
6219	ZZ	2RS	NR	95	170	32	2.1	109.0	82.0	2.62
6220	ZZ	2RS	NR	100	180	34	2.1	122.0	93.0	3.14
6221	ZZ	2RS	NR	105	190	36	2.1	133.0	105.0	3.7
6222	ZZ	2RS	NR	110	200	38	2.1	155.0	117.0	4.36
6224	ZZ	2RS	NR	120	215	40	2.1	167.0	131.0	5.15
6226	ZZ	2RS	NR	130	230	40	3	167.0	146.0	5.82
6300	ZZ	2RS	NR	10	35	11	0.6	8.2	3.5	0.053
6301	ZZ	2RS	NR	12	37	12	1	9.7	4.2	0.060
6302	ZZ	2RS	NR	15	42	13	1	11.4	5.45	0.082
6303	ZZ	2RS	NR	17	47	14	1	13.5	6.55	0.115
6304	ZZ	2RS	NR	20	52	15	1.1	15.9	7.9	0.144
6305	ZZ	2RS	NR	25	62	17	1.1	21.2	10.9	0.232
6306	ZZ	2RS	NR	30	72	19	1.1	26.7	15.0	0.360
6307	ZZ	2RS	NR	35	80	21	1.5	33.5	19.1	0.457
6308	ZZ	2RS	NR	40	90	23	1.5	40.5	24	0.630
6309	ZZ	2RS	NR	45	100	25	1.5	53.0	32.0	0.814
6310	ZZ	2RS	NR	50	110	27	2	62.0	38.5	1.07
6311	ZZ	2RS	NR	55	120	29	2	71.5	45.0	1.37
6312	ZZ	2RS	NR	60	130	31	2.1	82.0	52.0	1.73
6313	ZZ	2RS	NR	65	140	33	2.1	92.5	60.0	2.08
6314	ZZ	2RS	NR	70	150	35	2.1	104.0	68.0	2.52
6315	ZZ	2RS	NR	75	160	37	2.1	113.0	77.0	3.02
6316	ZZ	2RS	NR	80	170	39	2.1	123.0	86.5	3.59
6317	ZZ	2RS	NR	85	180	41	3	133.0	97.0	4.23
6318	ZZ	2RS	NR	90	190	43	3	143.0	107.0	4.91
6319	ZZ	2RS	NR	95	200	45	3	153.0	119.0	5.67
6320	ZZ	2RS	NR	100	215	47	3	173.0	141.0	7.00
6321	ZZ	2RS	NR	105	225	49	3	184.0	153.0	8.05
6322	ZZ	2RS	NR	110	240	50	3	205.0	179.0	9.54
6324	ZZ	2RS	NR	120	260	55	3	207.0	185.0	12.4
6326	ZZ	2RS	NR	130	280	58	4	229.0	214.0	15.3
6328	ZZ	2RS	NR	140	300	62	4	253.0	246.0	18.5
6403	ZZ	2RS	NR	17	62	17	1.1	22.7	10.8	0.270
6404	ZZ	2RS	NR	20	72	19	1	28.5	13.9	0.400
6405	ZZ	2RS	NR	25	80	21	1.1	34.5	17.5	0.530
6406	ZZ	2RS	NR	30	90	23	5	43.5	23.9	0.735
6407	ZZ	2RS	NR	35	100	25	1.5	55.0	31.0	0.952
6408	ZZ	2RS	NR	40	110	27	2	63.5	36.5	1.23
6409	ZZ	2RS	NR	45	120	29	2	77.0	45.0	1.53
6410	ZZ	2RS	NR	50	130	31	2.1	83.0	49.5	1.88
6411	ZZ	2RS	NR	55	140	33	2.1	89.0	54.0	2.29
6412	ZZ	2RS	NR	60	150	35	2.1	102.0	64.5	2.77
6413	ZZ	2RS	NR	65	160	37	2.1	111.0	72.5	3.30
6414	ZZ	2RS	NR	70	180	42	3	128.0	89.5	4.83
6415	ZZ	2RS	NR	75	190	45	3	138.0	99.0	5.72
6416	ZZ	2RS	NR	80	200	48	3	164.0	125.0	6.76
6417	ZZ	2RS	NR	85	210	52	4	165.0	128.0	7.95
6418	ZZ	2RS	NR	90	225	54	4	184.0	149.0	11.4

调心滚子轴承  
SPHERICAL ROLLER BEARING

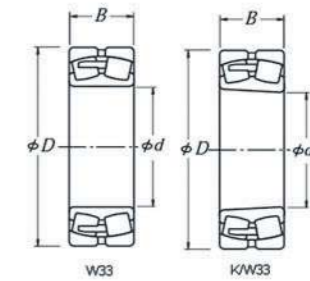

型号 Cylindrical Bore		主要尺寸 Boundary dimensions (mm)			重量 Weight (kg)
型号 Tapered Bore	d	D	B		
22206	22206K	30	62	20	0.26
22207	22207K	35	72	23	0.39
22208	22208K	40	80	23	0.48
22209	22209K	45	85	23	0.53
22210	22210K	50	90	23	0.57
22211	22211K	55	100	25	0.76
22212	22212K	60	110	28	1.04
22213	22213K	65	120	31	1.43
22214	22214K	70	125	31	1.51
22215	22215K	75	130	31	1.59
22216	22216K	80	140	33	1.93
22217	22217K	85	150	36	2.41
22218	22218K	90	160	40	3.11
22219	22219K	95	170	43	3.82
22220	22220K	100	180	46	4.62
22222	22222K	110	200	53	6.78
22224	22224K	120	215	58	8.45
22226	22226K	130	230	64	10.5
22228	22228K	140	250	68	14.5
22230	22230K	150	270	73	18.4
22308	22308K	40	90	33	0.96
22309	22309K	45	100	36	1.28
22310	22310K	50	110	40	1.67
22311	22311K	55	120	43	2.19
22312	22312K	60	130	46	2.72
22313	22313K	65	140	48	3.34
22314	22314K	70	150	51	4.04
22315	22315K	75	160	55	4.96
22316	22316K	80	170	58	5.91

型号 Cylindrical Bore		主要尺寸 Boundary dimensions (mm)			重量 Weight (kg)
型号 Tapered Bore	d	D	B		
22317	22317K	85	180	60	6.72
22318	22318K	90	190	64	8.06
22319	22319K	95	200	67	9.3
22320	22320K	100	215	73	12.2
22322	22322K	110	240	80	17
22324	22324K	120	260	86	22.2
22326	22326K	130	280	93	27.4
22328	22328K	140	300	102	34.3
22330	22330K	150	320	108	41.7
23022	23022K	110	170	45	3.75
23024	23024K	120	180	46	4.11
23122	23122K	110	180	56	5.7
23124	23124K	120	200	62	7.84
23126	23126K	130	210	64	8.68
23128	23128K	140	225	68	10.5
23130	23130K	150	250	80	15.8
23132	23132K	160	270	86	20.3
23134	23134K	170	280	88	21.8
23136	23136K	180	300	96	27.5
23138	23138K	190	320	104	34.5
23140	23140K	200	340	112	42.6
23218	23218K	90	160	52.4	4.52
23220	23220K	100	180	60.3	6.6
23222	23222K	110	200	69.8	9.54
23224	23224K	120	215	76	12.1
23226	23226K	130	230	80	14.3
23228	23228K	140	250	88	18.8
23230	23230K	150	270	96	24.2

推力球轴承  
Thrust Ball Bearing

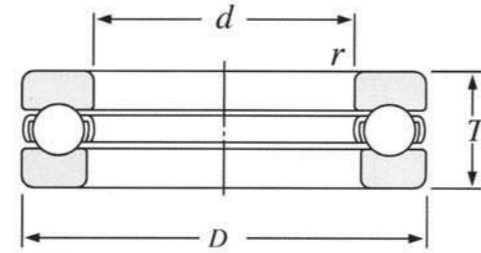

型号 Bearing No.	主要尺寸(mm) Boundary dimensions				基本负荷 Basic load ratings (KN)		重量 Weight kg
	d	D	T	r <sub>min</sub>	Cr	Cor	
51100	10	24	9	0.3	10	14	0.021
51101	12	26	9	0.3	10.3	15.4	0.023
51102	15	28	9	0.3	10.5	16.8	0.024
51103	17	30	9	0.3	10.8	18.2	0.026
51104	20	35	10	0.3	14.2	24.7	0.040
51105	25	42	11	0.6	19.6	37.0	0.060
51106	30	47	11	0.6	20.4	42.0	0.069
51107	35	52	12	0.6	20.4	44.5	0.085
51108	40	60	13	0.6	26.9	63.0	0.125
51109	45	65	14	0.6	27.9	69.0	0.148
51110	50	70	14	0.6	28.8	75.5	0.161
51111	55	78	16	0.6	35.0	93.0	0.226
51112	60	85	17	1	41.5	113.0	0.296
51113	65	90	18	1	41.5	117.0	0.338
51114	70	95	18	1	43.0	127.0	0.356
51115	75	100	19	1	44.5	136.0	0.399
51116	80	105	19	1	44.5	141.0	0.422
51117	85	110	19	1	46.0	150.0	0.444
51118	90	120	22	1	29.5	190.0	0.687
51120	100	135	25	1	85.0	268.0	0.987
51122	110	145	25	1	87	288	1.07
51124	120	155	25	1	89	310	1.11
51126	130	170	30	1	104	350	1.73
51128	140	180	31	1	107	375	1.90
51130	150	190	31	1	109	400	2.00
51132	160	200	31	1	112	425	2.10
51134	170	215	34	1.1	134	510	2.77
51136	180	225	34	1.1	135	525	2.92
51138	190	240	37	1.1	170	655	3.75
51140	200	250	37	1.1	172	675	3.92
51144	220	270	37	1.1	177	740	4.27
51148	240	300	45	1.5	228	935	6.87
51152	260	320	45	1.5	232	990	7.38
51156	280	350	53	1.5	305	1270	11.8
51160	300	280	62	2	355	1560	17.2

圆锥滚子轴承  
Tapered Roller Bearing

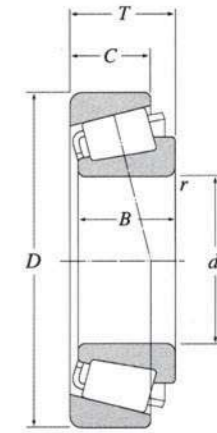

型号 Bearing No.	主要尺寸(mm) Boundary dimensions						基本负荷 Basic load ratings (KN)		重量 Weight kg
	d	D	T	B	C	r <sub>min</sub>	Cr	Cor	
30203	17	40	13.25	12	11	1	20.5	20.3	0.080
30204	20	47	15.25	14	12	1	28.2	28.7	0.127
30205	25	52	16.25	15	13	1	31.5	34	0.154
30206	30	62	17.25	16	14	1	43.5	48	0.241
30207	35	72	18.25	17	15	1.5	55.5	61.5	0.344
30208	40	80	19.75	18	16	1.5	61	67	0.435
30209	45	85	20.75	19	16	1.5	67.5	78.5	0.495
30210	50	90	21.75	20	17	1.5	77	93	0.563
30211	55	100	22.75	21	18	2	93	111	0.74
30212	60	110	23.75	22	19	2	105	125	0.949
30213	65	120	24.75	23	20	2	123	148	1.18
30214	70	125	26.25	24	21	2	131	162	1.26
30215	75	130	27.25	25	22	2	139	175	1.41
30216	80	140	28.25	26	22	2.5	160	200	1.72
30217	85	150	30.5	28	24	2.5	183	232	2.14
30218	90	160	32.5	30	26	2.5	208	267	2.66
30219	95	170	34.5	32	27	3	226	290	3.07
30220	100	180	37	34	29	3	258	335	3.78
30221	105	190	39	36	30	3	287	380	4.39
30222	110	200	41	38	32	3	325	435	5.18
30224	120	215	43.5	40	34	3	345	470	6.23
30226	130	230	43.75	40	34	4	375	505	7.25
30303	17	47	15.25	14	12	1	28.9	26.3	0.134
30304	20	52	16.25	15	13	1.5	35.5	34	0.160
30305	25	62	18.25	17	15	1.5	48.5	47.5	0.272
30306	30	72	20.75	19	16	1.5	60	61	0.408
30307	35	80	22.75	21	18	2	75	77	0.540
30308	40	90	25.25	23	20	2	91.5	102	0.769
30309	45	100	27.25	25	22	2	111	126	1.01
30310	50	110	29.25	27	23	2.5	133	152	1.31
30311	55	120	31.5	29	25	2.5	155	179	1.66
30312	60	130	33.5	31	22	3	180	210	2.06
30313	65	140	36	33	28	3	203	238	2.55
30314	70	150	38	35	30	3	230	272	3.06
30315	75	160	40	37	31	3	255	305	3.57
30316	80	170	42.5	39	33	3	291	350	4.41
30317	85	180	44.5	41	34	4	305	365	5.20
30318	90	190	46.5	43	36	4	335	405	6.03
30319	95	200	49.5	45	38	4	365	445	6.98

型号 Bearing No.	主要尺寸 (mm) Boundary dimensions						基本负荷 Basic load ratings (kN)		重量 Weight kg
	d	D	T	B	C	r <sub>smin</sub>	Cr	Cor	
32005	25	47	15	15	11.5	0.6	27.8	33.5	0.114
32006	30	55	17	17	13	1	37.5	46	0.166
32007	35	62	18	18	14	1	41.5	52.5	0.224
32008	40	68	19	19	14.5	1	50	65.5	0.273
32009	45	75	20	20	15.5	1	57.5	76.5	0.346
32010	50	80	20	20	15.5	1	62.5	88	0.366
32011	55	90	23	23	17.5	1.5	80.5	118	0.563
32012	60	95	23	23	17.5	1.5	82	123	0.576
32013	65	100	23	23	17.5	1.5	83	128	0.630
32014	70	110	25	25	19	1.5	105	160	0.848
32015	75	115	25	25	19	1.5	106	167	0.909
32016	80	125	29	29	22	1.5	139	216	1.28
32017	85	130	29	29	22	1.5	142	224	1.35
32018	90	140	32	32	24	2	168	270	1.79
32019	95	145	32	32	24	2	171	280	1.83
32020	100	150	32	32	24	2	170	281	1.91
32021	105	160	35	35	26	2.5	201	335	2.42
32022	110	170	38	38	29	2.5	236	390	3.07
32205	25	52	19.25	18	16	1	42	47	0.187
32206	30	62	21.25	20	17	1	54.5	64	0.301
32207	35	72	24.25	23	19	1.5	72.5	87	0.457
32208	40	80	24.75	23	19	1.5	79.5	93.5	0.558
32209	45	85	24.75	23	19	1.5	82	100	0.607
32210	50	90	24.75	23	19	1.5	87.5	109	0.648
32211	55	100	26.75	25	21	2	108	134	0.876
32212	60	110	29.75	28	24	2	130	164	1.18
32213	65	120	32.75	31	27	2	159	206	1.58
32214	70	125	33.25	31	27	2	166	220	1.68
32215	75	130	33.25	31	27	2	168	224	1.74
32216	80	140	35.25	33	28	2.5	199	265	2.18
32217	85	150	38.5	36	30	2.5	224	300	2.75
32218	90	160	42.5	60	34	2.5	262	360	3.49
32219	95	170	45.5	43	37	3	299	415	4.30
32220	100	180	49	46	39	3	330	465	5.12
32305	25	62	25.25	24	20	1.5	61.5	64.5	0.381
32306	30	72	28.75	27	23	1.5	81	90	0.583
32307	35	80	32.75	31	25	2	101	115	0.787
32308	40	90	35.25	33	27	2	122	150	1.08
32309	45	100	38.25	36	30	2	154	191	1.46
32310	50	110	42.25	40	33	2.5	184	232	1.92
32311	55	120	45.5	43	35	2.5	215	275	2.44
32312	60	130	48.5	46	37	3	244	315	3.02
32313	65	140	51	48	39	3	273	350	3.66
32314	70	150	54	51	42	3	310	405	4.46
32315	75	160	58	55	45	3	355	470	5.35
32316	80	170	61.5	58	48	3	395	525	6.41
32317	85	180	63.5	60	49	4	405	525	7.15
32318	90	190	67.5	64	53	4	450	595	8.75
32319	95	200	71.5	67	55	4	505	670	10.10
32320	100	215	77.5	73	60	4	570	770	12.7
32321	105	225	81.5	77	63	4	610	825	14.5



**STRONG COMMITMENT MAKES US PROFESSIONAL!**