

EXCELLENT TOOLS



Excellent Tools

Mr. Pandurang Solankar

Office Address :- Sr.No-74/2,Adarsh Nagar,
Dighi,Pune-411015.

Company Address :- Gate No-446, Shop No-2 Khadi
Machine Road, OR Charoli road Near Sant krupa Travels,
MIDC Moshi , Pune-412105.

Contact Number :- 9767029459, 8999501191

Email: solankarexcellenttools.2022@gmail.com

Website-www.excellentautomationtools.com





Excellent Tools

VISION & MISSION

OUR VISION

We will be the first choice of Customers in the Industry by being innovative Product manufacturing, proactive and complete value added Sheet Metal Dies and Mould & all Types Precisions work solutions provider.

OUR MISSION

Our mission is to produce Jigs fixture, and Inspection Gauges BIW Welding Fixture , Automation Base SPM ,Sheet Metal Press Tools , Progressive Tool, products for our customers, to meet their quality and delivery time requirements, provide advice and technical support.



Excellent Tools

❑ Company Profile

Established in the year **2020**, “**Excellent Tools**”, have gained recognition in TOOL Room Works. We ensure that the entire business operation is carried out according to a strict quality system. Owing to this dedicated hard-work, we have been able to supply this exclusive range of engineering products to our esteemed customers.

Our skilled operator team of personnel takes preventative measures to assure that favorable environment is maintained to ensure protection of the products from all kinds of environmental hazards. Our ethical business policies coupled with transparent dealings have helped us to attain a respectable position in the industry.



□ Our Mission

Our main business objective is to be the best provider for Engineering products. With innovative and high quality products, we ensure sustainable economic growth and a constant contribution to the group's success.

We pursue this goal consistently by

- Developing products which stand for quality and safety and further more set standards in terms of innovation and outstanding design.
- Ensuring powerful and efficient processes.
- Looking at our employees as key success factor and offering them an attractive working environment.
- Being a reliable and long-term oriented partner for our customers, suppliers, employees and colleagues.



Company Organization

Director

Design Team

2-BE MECH

Execution Team

2-BE MECH

QC Team

2-BE MECH

Manufacturing

6-ITI



☐ Machine Shop

Facilities Available

- Area 3000 Sq. Ft.
- VMC (04) (Vendor scope register Agreement)
- Universal Milling (01) Inhouse
- M1TR (02) Inhouse
- Lathe (02) 9 feet and 5 feet- Inhouse
- Faro Arm (CMM)10ft (1) (Vendor scope register Agreement)
- Wire Cut Machine (3) (Vendor scope register Agreement)
- CNC EDM Drill Machine (2) (Vendor scope register Agreement)
- CNC EDM Machine (3) (Vendor scope register Agreement)



List of Machinery

Sr. No.	Machine	Make	Model	Travel length X Y Z (MM)	Weighing Capacity in Kg	REMARKS
1	EDM-01	HSPK	HF-130	800+800 X 600 X 400	8000	Double Head
2	EDM-02	HSPK	HF-130	800+800 X 600 X 400	8000	Double Head
3	EDM-03	HSPK	HG-110	700+700 X 500 X 400	6000	Double Head
4	EDM-04	VINPAK	PRIMA	275X200X250	500	Single Head
4	WIRE CUT-01	HSPK	DS-640	650X400X310	1600	
5	WIRE CUT-02	EXCETEC	EX-400	400X300X220	500	
6	WIRE CUT-03	BQ	BQ-400	400X300X220	500	
7	EDM DRILL 01	ECOLINE	EL200	450 X 350 X 350+300	500	
8	VMC-01	COSMOS	CVM800			



Excellent Tools

□ Our Machines

1. Vertical Machining Centers (VMC)

- Make : Indian
- Control : Mitsubishi
- Bed Size :
1050X600x600mm
- Travel Limits : X,Y-,Z



❑ CNC EDM MACHINE DUBLE HEAD



CNC TWINS HEAD EDM_HSPK HF-130

TRAVEL LENGTH X Y Z (MM)	800+800 X 600 X 400
WORK TANK (MM)	2500 X 1250
MAX JOB HIGHT (MM)	900
MAX JOB WEIGHT (KG)	8000
MAX ELECTRODE WEIGHT (KG)	150
ELECTRODE WEAR (%)	0.3
FINISH (M RA)	0.2



❑ EDM WIRE CUT MACHINE



HSPK DS-640

TRAVEL LENGTH X Y Z (MM)	650X400X310
WORK TANK (MM)	1200X800
MAX JOB HIGHT (MM)	315
MAX JOB WEIGHT (KG)	1600
WIRE DIAMETER (MM)	0.25
FINISH (M RA)	0.2

❑ EDM WIRE CUT MACHINE



ZNC VINPAK PRIMA

TRAVEL LENGTH X Y Z (MM)	275 X 200 X 250
WORK TANK (MM)	600 X 400
MAX JOB HIGHT (MM)	350
MAX JOB WEIGHT (KG)	500
MAX ELECTRODE WEIGHT (KG)	50
ELECTRODE WEAR (%)	0.3
FINISH (M RA)	0.2

□ EDM DRILL MACHINE



ECOLINE EL200

TRAVEL LENGTH X Y Z (MM)	450 X 350 X 350+300
WORK TANK (MM)	400X320
MAX JOB HIGHT (MM)	500
MAX JOB WEIGHT (KG)	500
ELECTRODE DIA. (MM)	0.3 to 3



Our VMC Machines

- Make : Indian
- Control : Mitsubishi
- Bed Size :
1050X600x600mm
- Travel Limits : X,Y-,Z





Excellent Tools

2. DRO Machine 900 x 400 x 350 - 02nos

Machine Specifications :

- MAKE : TAIWAN
- Bed Size : 1250x400 mm
- Travel Limits : X-1000,
Y-350,Z-300 mm



M1TR

3. Milling Machine 1000 X 400 - 01 Nos

Universal Milling :

- Make : DOFOUR Machine
Specifications
- Bed Size : 1250x500mm
- Travel Limits : X-1000,Y-450,Z-450
mm





Excellent Tools

4. Lathe 7.5ft :- 02 Nos

- Make : MINAR
- Bed Size : 7.5 Ft
- Dia: 300mm



5. Cylindrical Grinding 300x800 :- 01 Nos





Excellent Tools

7. Die Moulding



8. Welding Fixtures

Welding FIXTURES

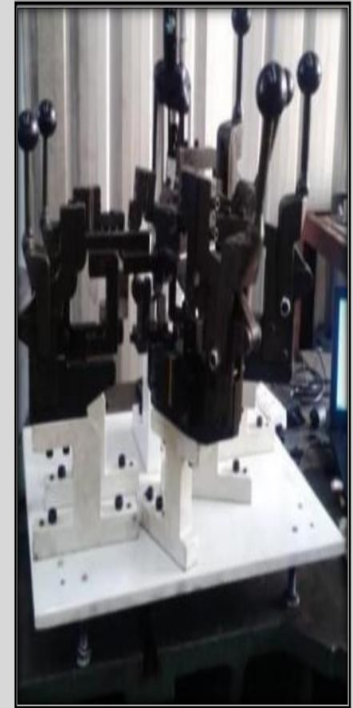
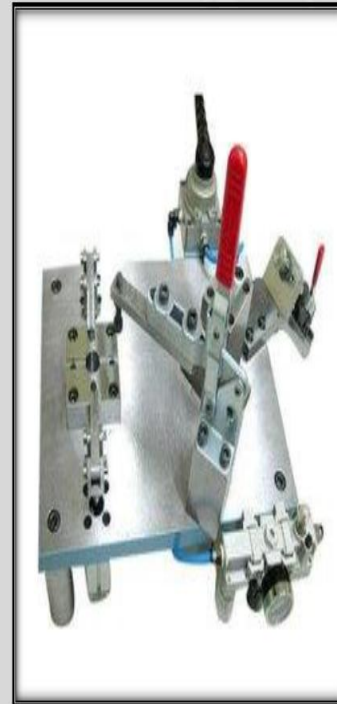



Our Manufacturing Products





Excellent Tools

Our Products- Parts of Kaveri Engine Aerospace



Part Name-COWL
Material-Inconel-



Part Name-Dome
Material-Inconel-



Excellent Tools

Our Products- IGES PHOTO of Kaveri Engine Aerospace



Hyd-Press 600 ton

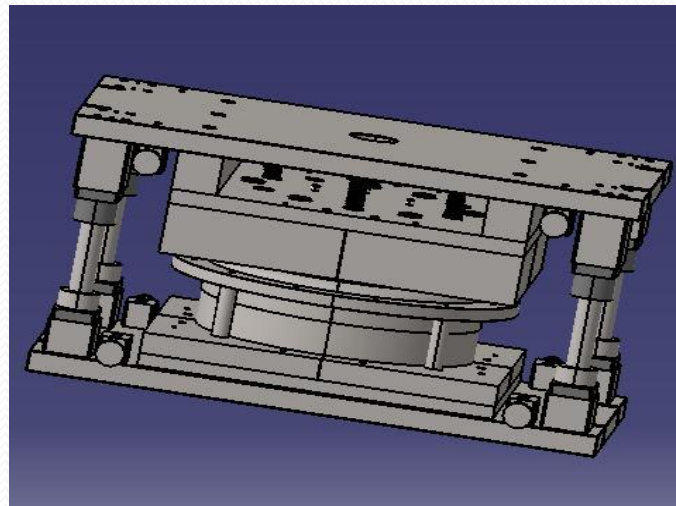
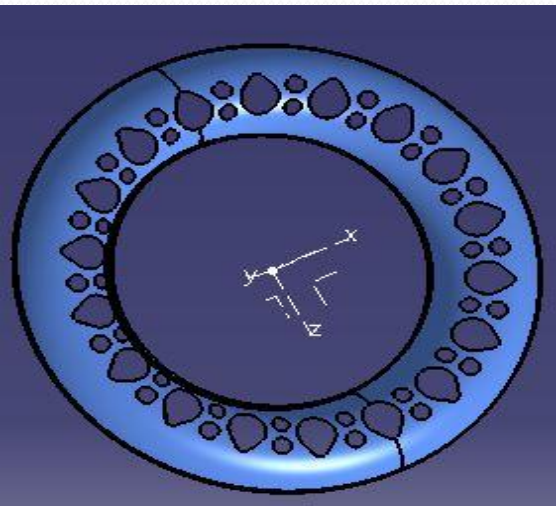

-Press Tool 4 ton



Excellent Tools

Our Products- High Precision work BEL Aerospace

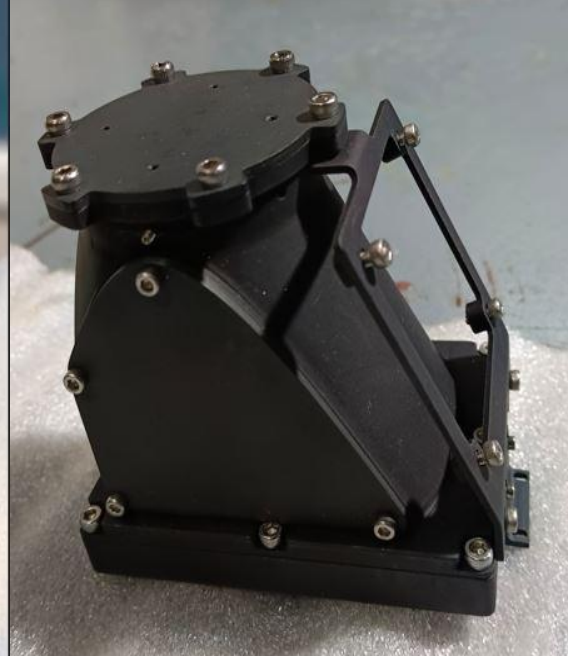
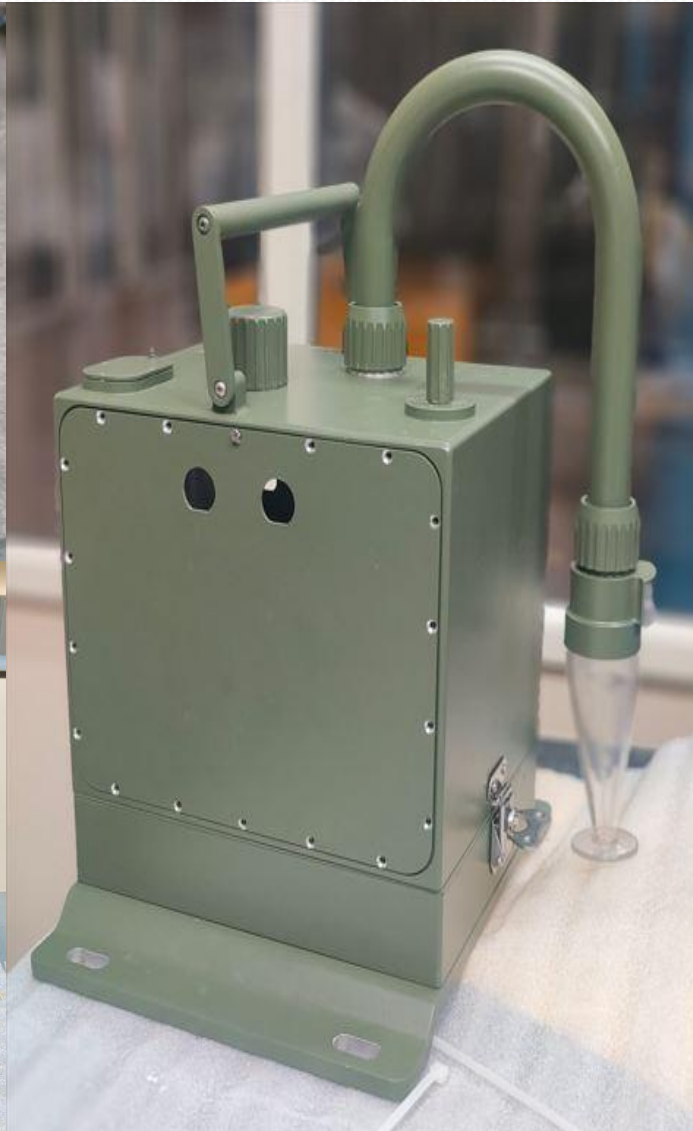
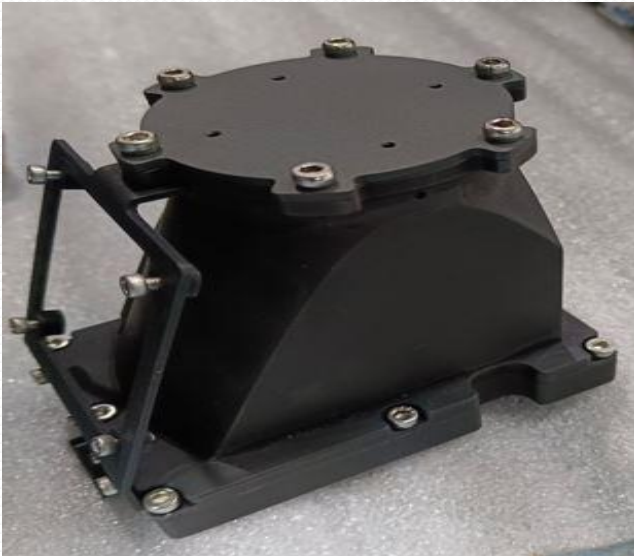

Our Products- Welding fixture and inspection gauge

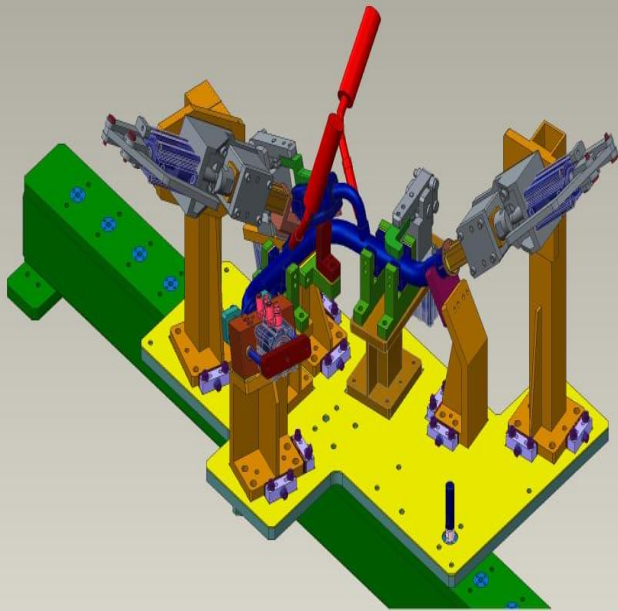

On-Demand Simp Rep:OP-280-MOD

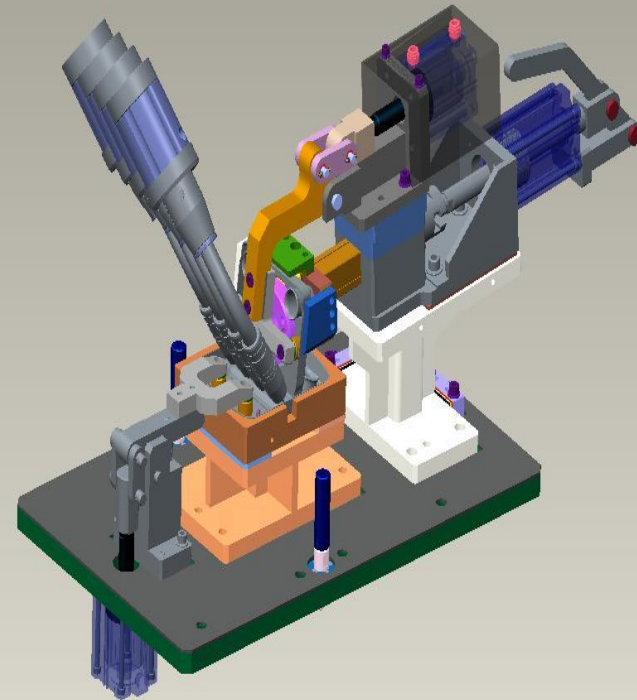

Insert Mode

X.X+0.1
X.XX+0.01
X.XXX+0.001
ANG+0.5

Our Products- Marking SPM

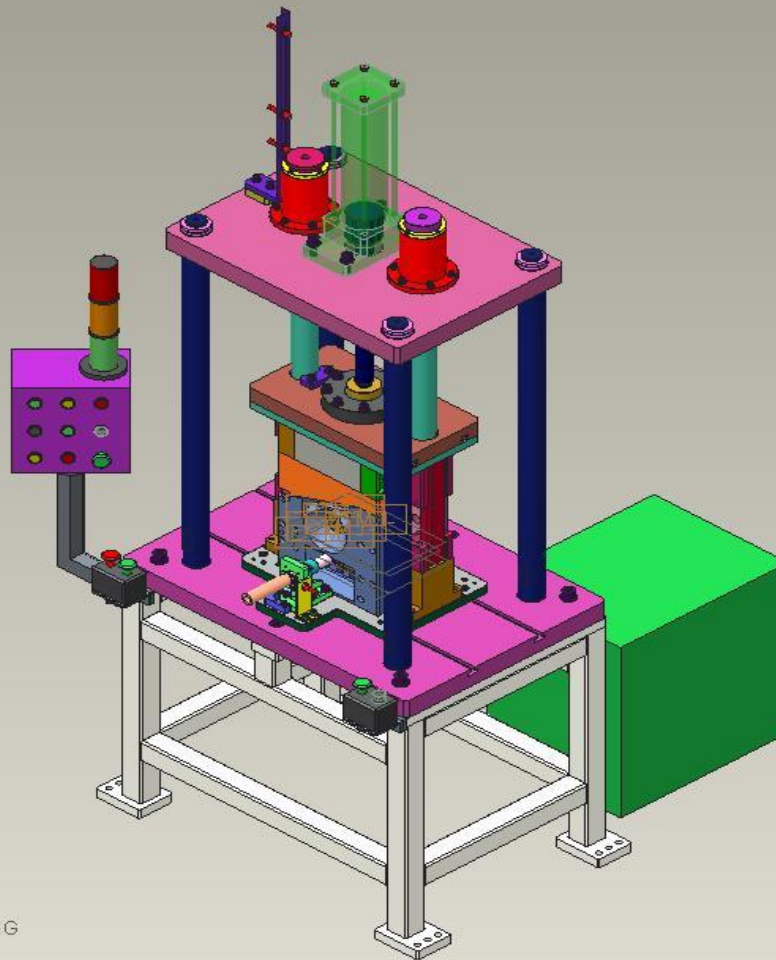

Insert Mode

On-Demand Simp Rep:CLAMPING

X.X+0.1
X.XX+0.01
X.XXX+0.001
ANG.+0.5

□ Our Products- Al-Round Welding SPM

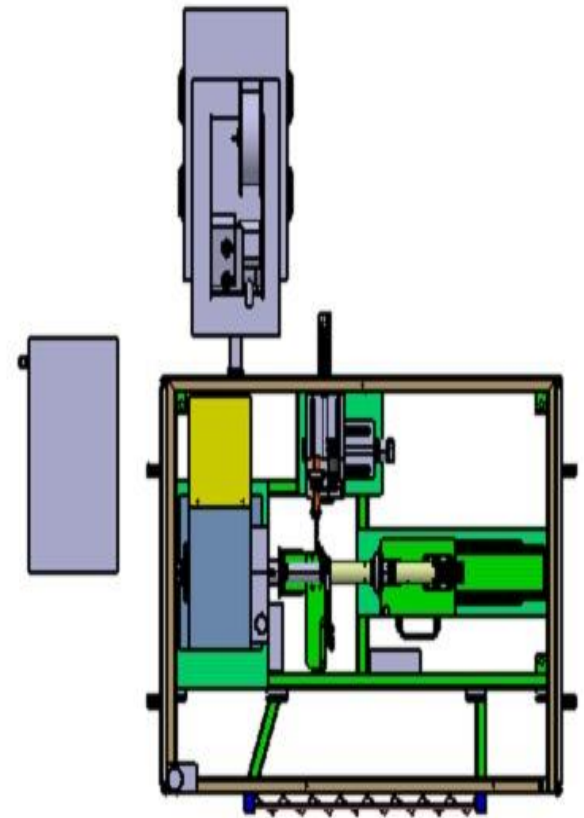
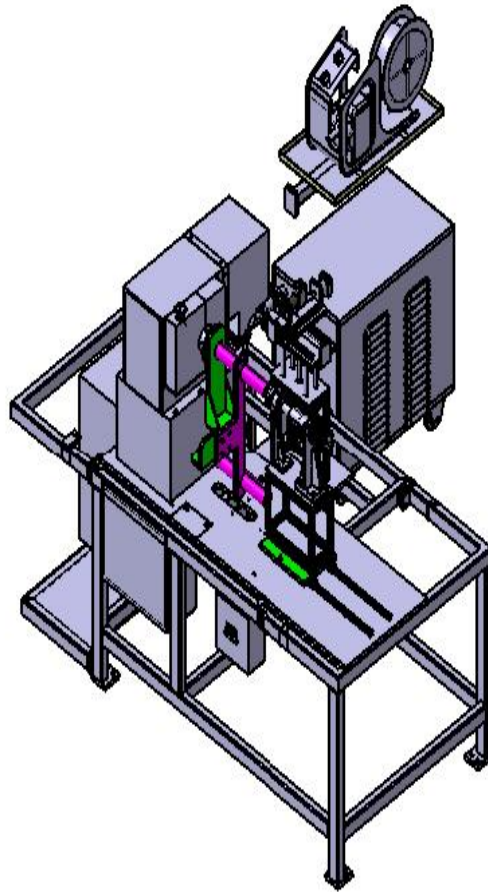
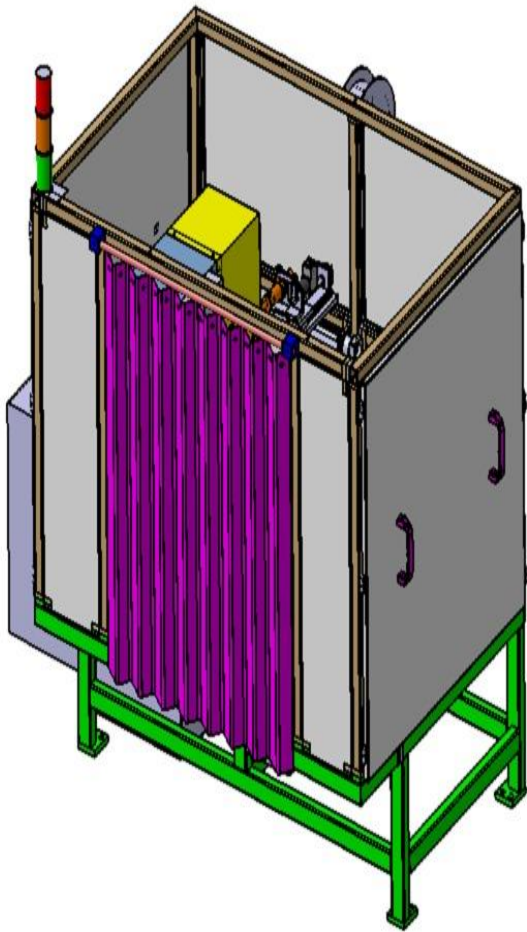

❑ Design and Manufacturing of Pick and Place Chain Conveyor

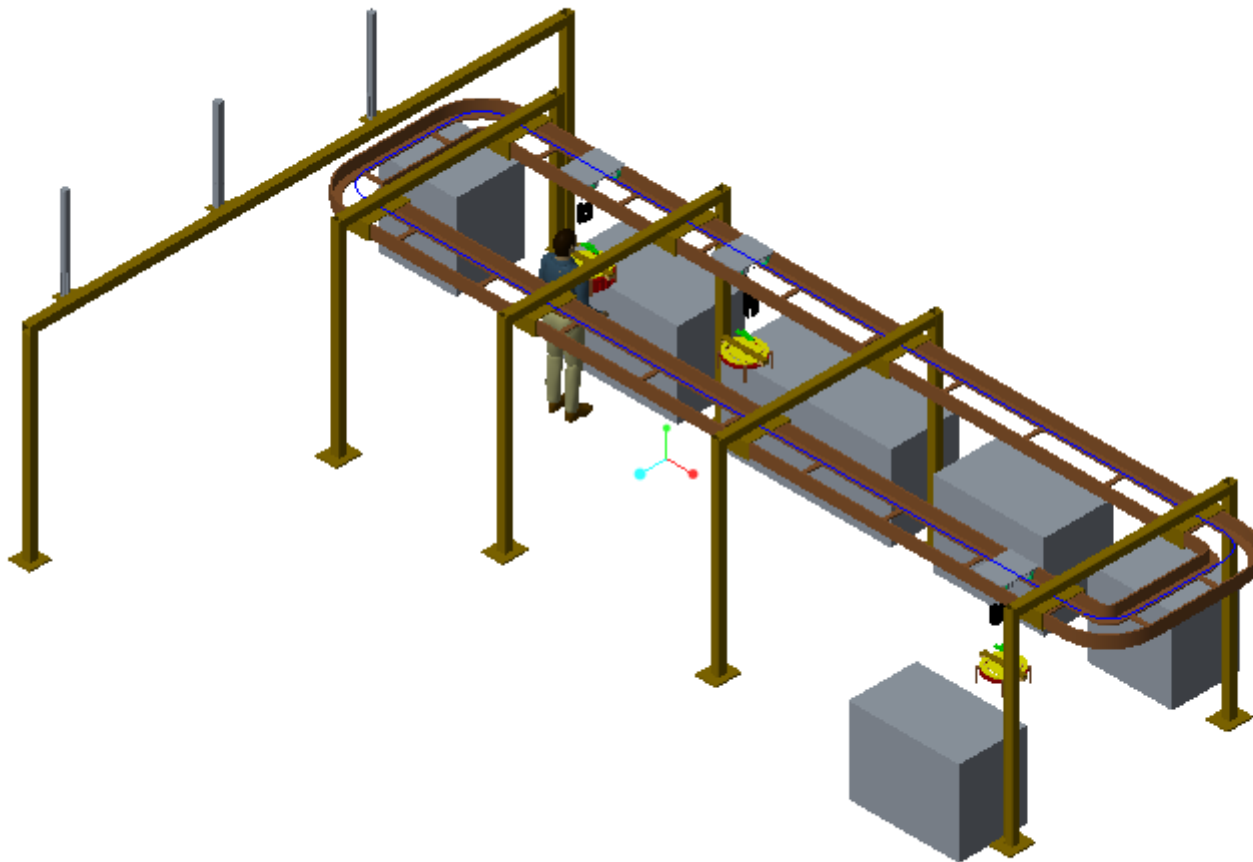

❑ Manufacturing Of Jigs And Fixtures (Inspection Gauge)

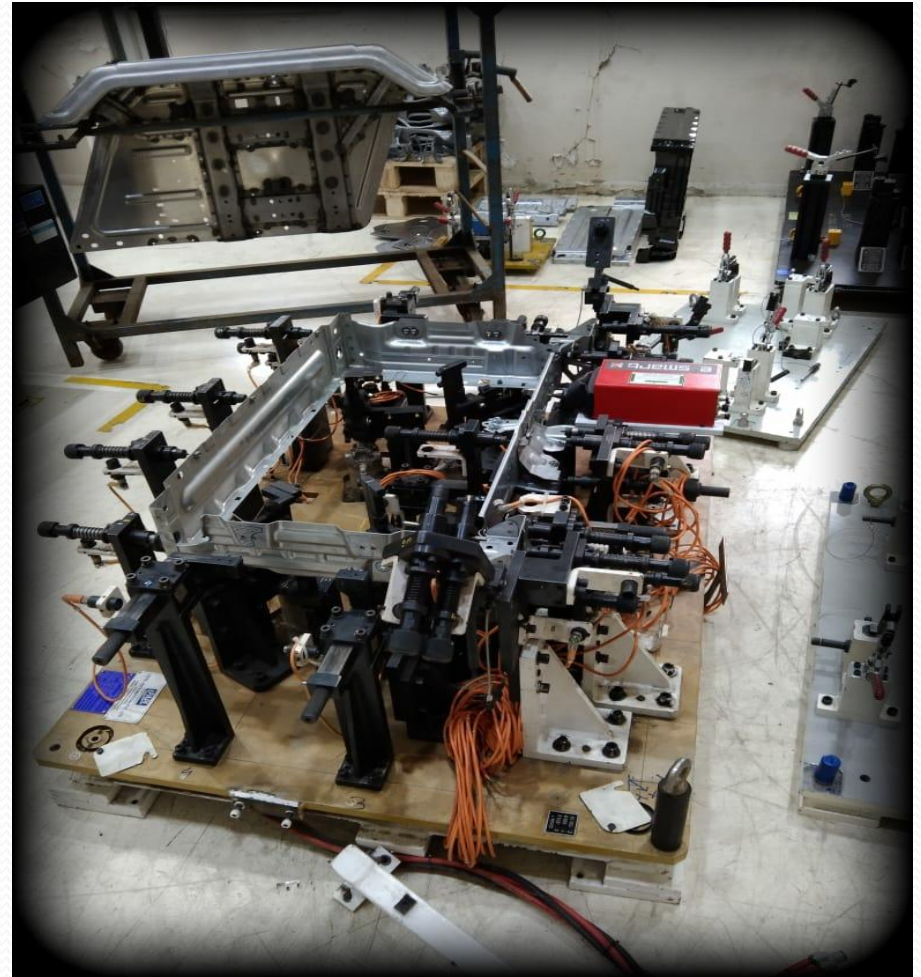
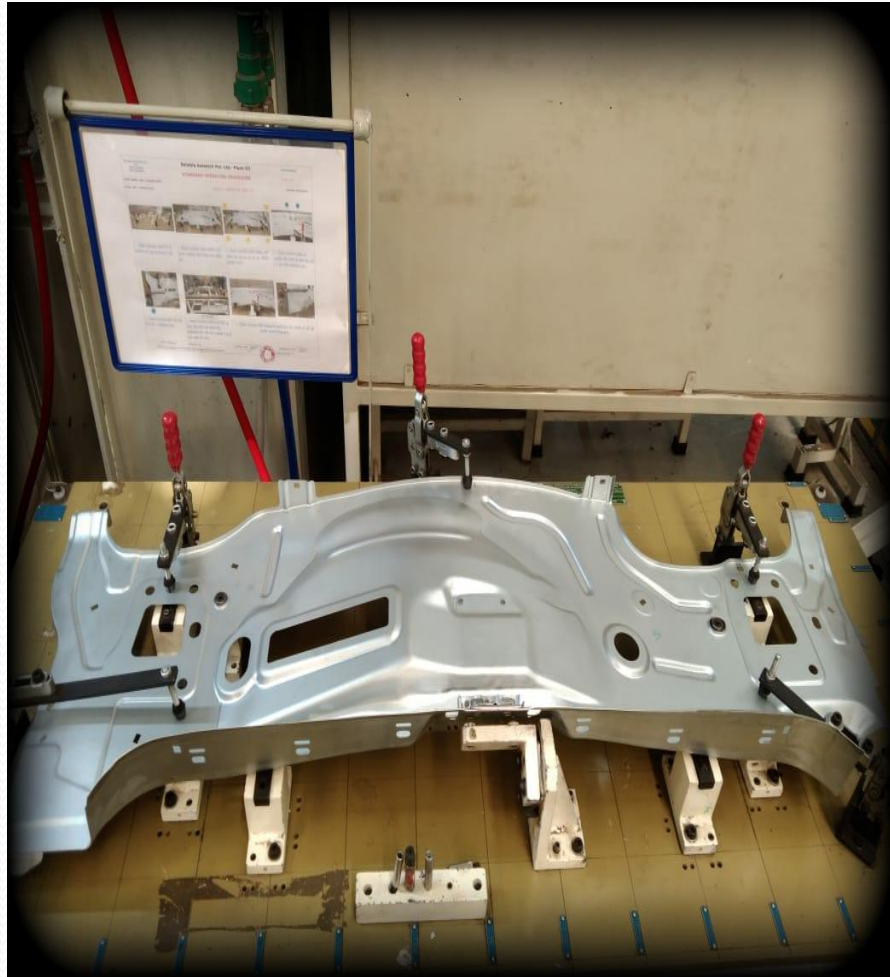



Excellent Tools

❑ Quality Equipment

1. HIGHT GAUGE DIGITAL- 01 NOS Range(0-300mm)
2. BORE GAUGE - 02NOS Range(18-35)(35-60mm))(60-150mm)
3. MICRO METER - 03NOS Range (0-25mm)(25-50mm)(50-150mm)
4. VERNIER CALIPER - 02NOS Range (0-100)(0-300mm)
5. DIGITAL VERNIER - 02NOS Range (0-200)(0-300mm)
6. Gauges (All Types)
7. Surface Table (1000mmx1000mmx150mm)
8. V-blocks (All Types)

9. Faro Arm CMM 10ft.





Excellent Tools

□ Our Customers

- Tata Katcon Exhaust System Pvt. Ltd.
- VG Marine Tech Pvt.Ltd.
- Reliable Auto Tech Pvt. Ltd.
- Horiba India Pvt.Ltd.
- Haosen Automation India Pvt.Ltd.
- Innovae3D Pvt.Ltd.
- Surin Automotive Pvt.Ltd.
- Talegaonkar Profiles Pvt.Ltd.



Excellent Tools



Thank you

www.excellentautomationtools.com