



Flow-age

ISO 9001: 2015 CERTIFIED COMPANY

FLOW-TEK VALVES & CONTROLS INC.

**PLOT NO. 172-173, ROAD NO. 4,
KATHWADA GIDC, AHMEDABAD
382430, GUJARAT, INDIA.**

(M): +919824539702 / 9824080899

(E): info@flowagevalves.com

hemal21386@gmail.com

**MANUFACTURER OF:
CORROSION RESISTANT FLUOROPOLYMERS &
PLASTIC LINED PRODUCTS, PROVIDING THE
WIDE RANGE OF PTFE/PFA/FEP/PVDF/ & PP
LINED VALVES, PIPE AND PIPE FITTINGS.**





MANUFACTURER OF CORROSION RESISTANT FLUOROPOLYMER & PLASTICLINED PRODUCTS, PROVIDING THE WIDE RANGE OF PTFE/ PFA/ FEP/ PVDF & PP LINED VALVES, PIPE AND PIPE FITTINGS FOR CHEMICAL INDUSTRIES.

INTRODUCTION

Since 1995, We **FLOW-TEK VALVES & INC** highly qualified technocrats having depth experience and industry's best proficiency in the field of **"PTFE/PFA/PVDF/PP Lined valves, pipes, pipes fittings and accessories of Glass lined reactors and maintenance Spares."** We are an **ISO 9001:2015** certified company. Our company is well established as a reliable and dependable name for above mention products. **We strive to provide timely services to our customers in the most efficient manner for various problems relating to corrosion prevention, chemical-resistance, high temperature services, electrical resistance, mechanical frictions, etc. in multifarious engineering areas.**

Our range of products are used in various industries such as Chemicals, Refineries, petrochemicals, food-processing, pesticides, Alcohols and acids, Pharmaceuticals, Fertilizers, textiles, pulps and paper etc.

Products at a glance:

Fluoropolymer & polymer Like PTFE / PFA / FEP / PVDF & PP LINED, Ball Valve, Ball check Valve, Flush bottom Valve, Butterfly Valve, Plug Valve, Diaphragm Valves, Swing check Valve, Y-Strainer, Basket strainer, Tee strainer, Spool Pipes, All type of pipe fittings, GLR (Glass lined reactor) vessels maintenance lined spare, PTFE Dip pipe with cum Spurger, lined Impeller Agitators and Anchors, thermo well and PTFE products etc.

FLOW-TEK are available in wide range of products like **(25NB to 300NB)** all types of lined valves, lined Pipes and Fittings. We are manufacturing customer's required products like **(100NB to 600NB)** lined Domes, lined vacuumed Coolum's **(up to 3 meters length in one peace), (40KL)** lined agitator etc.

We are committed to fulfill every single requirement of our clients and ensure their optimum satisfaction. For this, we offer them qualitative products and provide installation training, on-site support and operational training for the same. **FLOW-TEK** is serving Indian industries last **25 years**.

COMPANY PROFILE

- Name of the Company : **FLOW-TEK VALVES & CONTROLS INC.**
- Address : **Regd. Office:-**
Plot No. 172-173, Road No. 4, Kathwada
GIDC, Ahmedabad 382430, Gujarat, India.
- Works:**
Plot No. 172-173, Road No. 4, Kathwada
GIDC, Ahmedabad 382430, Gujarat, India.
- Phones : (M) :- +919824539702
+919824080899
+919725104304
- E-mail : info@flowagevalves.com // hemal21386@gmail.com
- Web address : www.flowtekvalves.com // www.flowagevalves.com
- Constitution : Small Scale Industry
- Date of Incorporation : 07/12/2005
- Type of Industry : Advance Engineering Corrosion Resist Fluoropolymer Lined valve, pipes and pipe fittings manufacturing.
- Certification : (TUV SUD ISO 9001:2015)
- GST No. : 24AABFF4592R1ZW (21/03/2017)
- Contact Person : PARTNER: - MR. KANUBHAI B PATEL
MR. HEMAL K PATEL
MR. JATIN P PATEL
- Production : Manufacturers of Fluoropolymer valves, pipes,
Pipe fittings and custom made Fluoropolymer products.
- Other activities : Industrial Valves & Automation Valves Manufacturer.
- Please click here for download catalog : **Industrial Valve Catalog Download**
Automation Valves Catalog Download

FLOW-TEK VALVES & CONTROLS INC

TABLE OF CONTENT

Sr. No.	DESCRIPTION	Page No.
01	FLUROPOLYMER PROPERTIES OF MATERIAL.	01
02	FLUROPOLYMER MATERIAL PROPERTIES AND SPECIFICATION.	02, 03
03	LINED VALVE GENERAL SPECIFICATION.	04, 05
: LINED VALVES :		
04	LINED BALL VALVE.	06
05	LINED GEAR OPERATED BALL VALVE.	07
06	LINED PLUG VALVE.	08
07	LINED DIOPHRAGM VALVE.	09
08	LINED BUTTERFLY VALVE.	10
09	LINED GEAR OPERATED BUTTERFLY VALVE.	11
10	LINED BALL CHECK VALVE.	12
11	LINED SWING CHECK VALVE.	13
12	LINED SIGHT FLOW INDICATOR.	14
13	LINED TUBULAR SIGHT GLASS.	15
14	LINED Y STRAINER.	16
15	LINED TEE STRAINER.	17
16	LINED BUCKET STRAINER.	18
17	LINED FLUSH BOTTOM VALVE.	19
: LINED PIPE AND FITTING :		
18	LINED PIPE AND FITTING GENERAL SPECIFICATION.	20, 21
19	INSTALLATION AND MAINTENANCE INSTRUCTIONS.	22
20	LINED PIPE.	23
21	LINED EQUAL TEE AND UNEQUAL TEE.	24
22	LINED 90° ELBOW.	25
23	LINED 45° ELBOW.	26
24	LINED CONCENTRIC REDUCER.	27
25	LINED ECCENTRIC REDUCER.	28
26	LINED BLIND FLANGE.	29
27	LINED CROSS.	30
28	LINED REDUCING FLANGE.	31
29	LINED INSTRUMENT TEE.	32
30	SOLID SPACER.	33

FLOW-TEK VALVES & CONTROLS INC

TABLE OF CONTENT

Sr. No.	DESCRIPTION	Page No.
31	LINED SPACER.	34
32	LINED 45° LATERAL.	35
33	PTFE EXPANSION BELLOW.	36
34	LINED MANIFOLD.	37
: SPARES FOR GLASS LINED EQUIPMENT :		
35	LINED IMPELLER AGITATOR.	38
36	LINED ANCHOR AGITATOR.	39
37	LINED THERMOWELL.	40
38	PTFE DIP PIPE CUM SPARGER.	41
39	PTFE GASKET.	42
40	PTFE NOZZLE BUSH.	43
41	LINED MANHOLE COVER.	44
42	LINED PROTECTOR RING.	45
43	LINED SPINDLE SPARES FOR FLUSH BOTTOM VALVE.	46
44	'C' CLAMP	47
45	SPLIT FLANGE	48
46	STUFFING BOX	49
47	LINED ADAPTOR RING	50
48	LINED PAD PLATE	51
: REPAIR KIT FOR GLASS LINED EQUIPMENT :		
49	LINED MASHROOM DISH REPAIR KIT.	52
50	LINED BLIND DISH REPAIR KIT.	53
51	LINED DISH AND BOLT REPAIR KIT.	54
52	LINED BOTTOM NOZZLE REPAIR KIT.	55
53	AT YOUR SITE MAINTENANCE PROCESS DATA	56
54	AT OUR SITE MAINTENANCE PROCESS DATA	57

FLOW-TEK VALVES & CONTROLS INC

FLUROPOLYMER PROPERTIES OF MATERIAL

Mechanical properties	ASTM Standard	Unit	PTFE	FEP	PFA	PVDF
Specific Gravity	D792	-	2.13-2.22	2.15	2.15	1.77-1.78
Tensile Strength	D1457 D1708 D638	Map(psi)	21-35 (3000-5000)	23(3400)	25(3600)	(6000-7000)
Elongation	D1457 D1708 D638	%	300-500	325	300	50-250
Flexural Modulus	D790	Map(psi)	500(72000)	600(85000)	600(85000)	(200000-325000)
Impact Strength	D256	J/m(ftLB/in)	189(3.5)	No Break	No Break	(2-4)
Hardness	D2240	Shore D	50-56	56	60	76-80
Coefficient of Friction, Dynamic	D1894	<3 m/min (<10ft/min)	0.1	0.2	0.2	0.44-0.76
Thermal Properties	ASTM Standard	Unit	PTFE	FEP	PFA	PVDF
Melting Point	D3418	°C (°F)	327(621)	260(500)	305(582)	(332-338)
Upper Service Temp.	UL746B	°C (°F)	260(500)	204(400)	260(500)	-40° TO 140°
Flame Rating**	UL94	-	VO	VO	VO	VO
Limiting Oxygen Index	D2863	%	>95	>95	>95	44
Hit Of Combustion	D240	MJ/Kg(Btu/LB)	5.1(2200)	5.1(2200)	5.3(2300)	N.A.
Electrical Properties	ASTM Standard	Unit	PTFE	FEP	PFA	PVDF
Dielectric Constant	D150	1MHz	2.1	2.1	2.1	8.40
Dissipation Factor	D150	1MHz	<0.0001	<0.0006	0.0001	0.049
Arc Resistance	D495	Sec	>300	>300	>180	-
Volume Resistivity	D257	Ohm cm	>10 ¹⁸	>10 ¹⁸	10 ¹⁸	>10 ¹⁷
Surface Resistivity	D257	Ohm/sq.	>10 ¹⁸	>10 ¹⁶	>10 ¹⁷	>10 ¹⁵
General Properties	ASTM Standard	Unit	PTFE	FEP	PFA	PVDF
Weather Resistance	Florida Exposure	Years Unaffected	20	20	10	15
Chemical/ Solvent Resistance	D543	-	Excellent	Excellent	Excellent	Excellent
Water Absorption, 24th	D570	%	<0.01	<0.01	<0.03	<0.03

*Typical values are unsuitable for specifications. Properties were measured at 23°C (73°F), unless otherwise noted.

**Statements regarding behavior in a flame situation are not intended to reflect hazards presented by this or any other material when under actual fire conditions.

FLUROPOLYMER MATERIAL PROPERTIES AND SPECIFICATION.

PTFE (POLY TETRAFLURO ETHYLENE) & PFA (PER FLURO ALKOXY)

This system is made up from distinct types of polymer, PTFE and PFA. PTFE is Polytetrafluoroethylene and PFA is Perfluoroalkoxy, a recently developed thermoplastic fluorocarbon polymer. PFA has all the excellent Corrosion and heat resistant of PTFE, but is processable by thermoplastic techniques.

Fittings are generally lined with PFA and Piping with PTFE. The polymers are mutually compatible and have a general service temperature ranging from -60°C to $+ 200^{\circ}\text{C}$. Satisfactory service has been archived with PTFE systems operating at $+ 260^{\circ}\text{C}$.

The chemical resistance of PTFE is unique in comparisons to other resins and even to metal or glass. It is virtually chemical inert to all commercial chemicals and solvents throughout the normal temperature range with exception of molten alkali metals, fluorine and chlorine trifluoride at high temperature and pressures. All of these unusual properties can be achieved and utilized in the final products only by careful control and the development of correct processing techniques. Control and techniques are far more precise with these resins, to obtain the ultimate properties, than is generally true of the majority of other plastic material.

PTFE lined pipe and fitting are being used to convey and are inert to the following broad general chemicals.

All acids including hydrofluoric, hydrochloric, sulphuric, and aqua regia. All solvents, All Caustics, All bleach solution, all chlorides- organic and inorganic, all sulphate – organic and inorganic, all peroxides, and all phenols.

Combined with the chemical inertness of PTFE are its unusual nonstick properties. Thus a PTFE lined pipe systems eliminates and minimizes buildup of deposits on the pipe wall which otherwise would reduce flow and possibly affect processing operations.

FLUROPOLYMER MATERIAL PROPERTIES AND SPECIFICATION.

FEP (FLURO ETHYLENE PROPYLENE)

FEP is based on a fluorinated copolymer of ethylene and propylene. The chemical resistance properties of FEP are generally the same as PTFE with the exception that the upper temperature operational limit is 150°C. The resin is true thermoplastic in that it has a melt point and is thus processable with conventional thermoplastic fabrication equipment capable of very high operational temperature.

This system, like PTFE, requires not only high temperature processing equipment but also precise controls and procedures to develop its outstanding ultimate properties.

PVDF (POLY VINYLIDENE FLUORIDE)

PVDF is a line pipe system using poly vinylidene fluoride resins. This material is crystalline homopolymer of vinylidene fluoride containing approximately 59% fluorine. The operational temperature range is generally between -20°C to + 120°C.

PVDF has excellent resistant to most corrosive chemicals and organic compounds including acids, alkalis, strong oxidizers and halogens. It is however attacked by fuming sulphuric acid at room temperature, by strong sulphuric and other sulphonating agents at high temperatures, Ketones and amines.

PVDF is thermally stable and no significant change has been noted even after two years exposures to a temperature of 150°C. The resistance of this resin to gamma radiation is exceptional. At a dosage level of 300 million roentgens, no change in strength and elongation was noted although there was some darkening in color of test specimen.

PVDF, similar to PTFE and FEP, requires precise control techniques to achieve the ultimate in properties and performance. BTR silver town with its many years of experience in processing difficult resins with high performance characteristics has developed the necessary procedures and quality controls to assure the optimum product performance.

P.P (POLY PROPYLENE)

P.P. is a polypropylene lined system with excellent temperature stability and good chemical resistance to a wide range of corrosive chemicals including acids, alkalis, some oxidizing agent and halogens. It has excellent resistance to weak acids, good resistance to strong acids but is not recommended for use with chlosulphonic acid and fuming nitric acid even at room temperature. It has excellent resistance to both weak and strong alkalis and generally satisfactory with organic solvents although it is affected by hot aromatic hydrocarbons and chlorinated hydrocarbons. Its wide chemical resistance is combined with a useful temperature range from -20°C to + 100°C.

FLOW-TEK VALVES & CONTROLS INC

LINED VALVE GENERAL SPECIFICATION

Material specification:-

Casting Material Specification:-

Ductile iron:	ASTM A395
Cast Steel:	ASTM A216, GR. – WCB
S.S 304:	ASTM A351 CF8
S.S 304L:	ASTM A351 CF3
S.S 316:	ASTM A351 CF8M
S.S 316L:	ASTM A351 CF3M
ALLOY20:	ASTM A351 CN7M

Design Standard:-

Ball Valve, 2 Piece:	BS 5351
Ball Valve, 3 Piece:	BS 5351
Plug Valve:	BS 5158
Diaphragm Valve:	BS 5156
Butterfly Valve:	BS 5155
Ball Check Valve:	BS 5351

Standard Resin Specification:-

PTFE:	ASTM D 1457
PFA:	ASTM D 3418
FEP:	ASTM D 2116
PVDF:	ASTM D 3222
P.P:	ASTM D 2146

Service Temperature:-

PTFE:	Maximum continues Service Temperature: 260°C and Melt Point: 327° C.
PFA:	Maximum continues Service Temperature: 265°C and Melt Point: 305° C.
FEP:	Maximum continues Service Temperature: 200°C and Melt Point: 260° C.
PVDF:	Maximum continues Service Temperature: 140°C and Melt Point: 170° C.
P.P.:	Maximum continues Service Temperature: 110°C and Melt Point: 200° C.

Lining Thickness:-

Minimum lining thickness would be **3.0mm** to **5.0mm** over all wetted portion.

FLOW-TEK VALVES & CONTROLS INC

LINED VALVE GENERAL SPECIFICATION

PFA/FEP/PVDF/PP LINED VALVES

Chemical Inertness:—

PTFE/PFA/FEP are chemically inert to most off the all chemicals & solvents with the exception of molten alkali metals.

PTFE/PFA/FEP lined valves are used to convey, & are inert to, these chemicals: All acids including hydrofluoric, sulphuric & aqua regia, all caustic, all chlorides—organic & inorganic, all solvents, all bleach solution, all peroxides, all phenols & any combinations of above materials.

Combined with chemical inertness of PTFE/PFA/FEP is its unique non—stick property. thus a PTFE/PFA/FEP lined products eliminate or minimize the built up of deposits of the products which otherwise reduce flow & affect processing operations.

Finish:—

The interior surface of all valves are clean & free of mould burrs, rust, scale or others that may adversely affect the performance of lining.

The exterior surface of all valve bodies are to be cleaned by sand / shot blasting & painted by one coat of epoxy primer & two coats of polyurethane top coat.

Product Inspection & testing:—

Hydrostatic Pressure:—

Body Test: 14Kg/Cm²

Seat Test: 14Kg/Cm²

Electrostatic Pressure:—

Conduct The test with Non—destructive high voltage tester at an output voltage of 10,000V. When electric contact is made, a visible/audible spark or both occur at the probe if there is any defect.

Visual Inspection:—

All surfaces are free from blister, porosity or any other defect. any defect has to be repaired before shipment.

Storage & Transport:—

Each end of valves are protected by wooden plate or polypropylene plate so that products are capable to withstand normal handling during transport.

All the materials are supplied with export wooden case or card box packing depending upon the weight & mode of shipment.

FLOW-TEK VALVES & CONTROLS INC

LINED BALL VALVE

FACE TO FACE : BS 5351
ALL DIMENSIONS ARE IN mm

SIZE NB	A	L
15	108	200
20	118	200
25	127	250
32	146	250
40	165	250
50	178	300
65	190	300
80	203	350
100	229	350
125	248	350
150	267	350

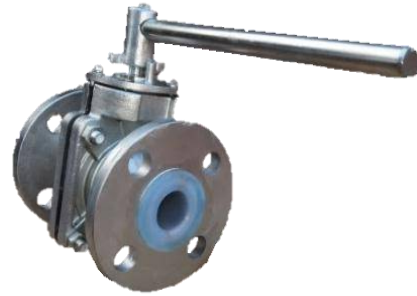
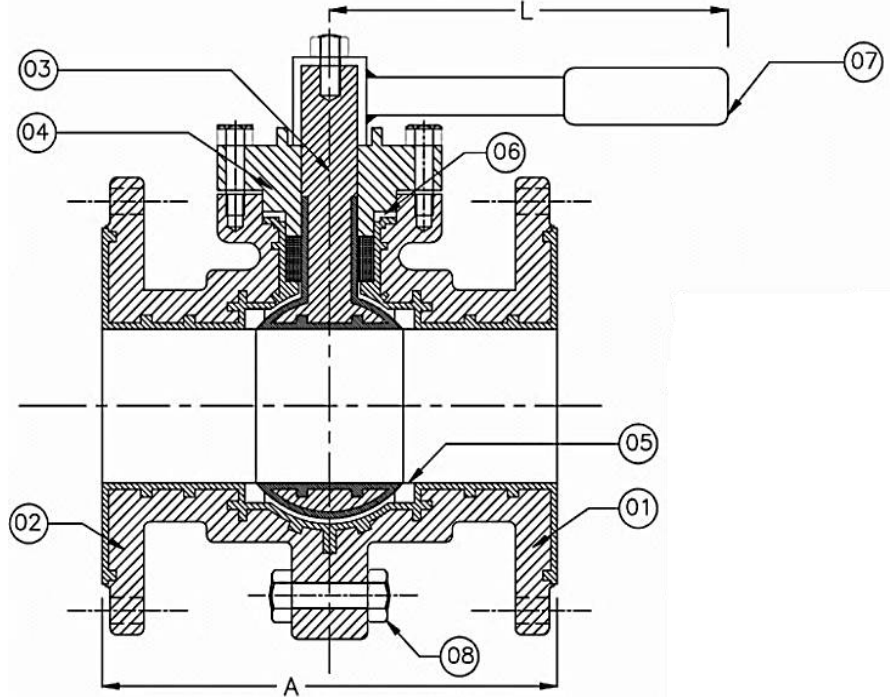

HSN CODE : 84818030

S. NO.	PART NAME	MATERIAL	TEST PRESSURE - HYD.	
01	BODY/FLANGE STANDARD • ANSI CLASS 150# • DIN PN 16 • JIS CLASS 10k	DI: ASTM A 395 CS: ASTM A 216 SS: ASTM A 182	METAL BODY WITHOUT LINING	28KG/CM ²
			METAL BODY WITH LINING	14KG/CM ²
02	LINING THICKNESS 3.0mm MIN. 5.0mm MAX.	PFA-ASTM D3307 FEP-ASTM D2116 PVDF-ASTM D3222 P.P.-ASTM D2146	SPARK TEST	15 KV D.C.

BILL OF MATERIAL

S. NO.	PART NAME	MATERIAL
1	SIDE PIECE	GRADED CI/DI/WCB/SS + PFA/FEP/PVDF/PP LINED
2	SIDE PIECE	GRADED CI/DI/WCB/SS + PFA/FEP/PVDF/PP LINED
3	BALL/STEM	DI/WCB/SS + PFA/FEP/PVDF/PP LINED
4	GLAND	DI/WCB/SS
5	SEAT RING	PTFE
6	GLAND RING	PTFE
7	CAP & HANDLE	MS
8	FASTENERS	MS/SS

CLIENT NAME. _____

DRAWING NO. _____

ORDER NO. _____

FLOW-TEK VALVES & CONTROLS INC

LINED GEAR OPERATED BALL VALVE

FACE TO FACE : BS 5351
ALL DIMENSIONS ARE IN mm

SIZE NB	A	L
150	267	200
200	292	200
250	533	250
300	610	250

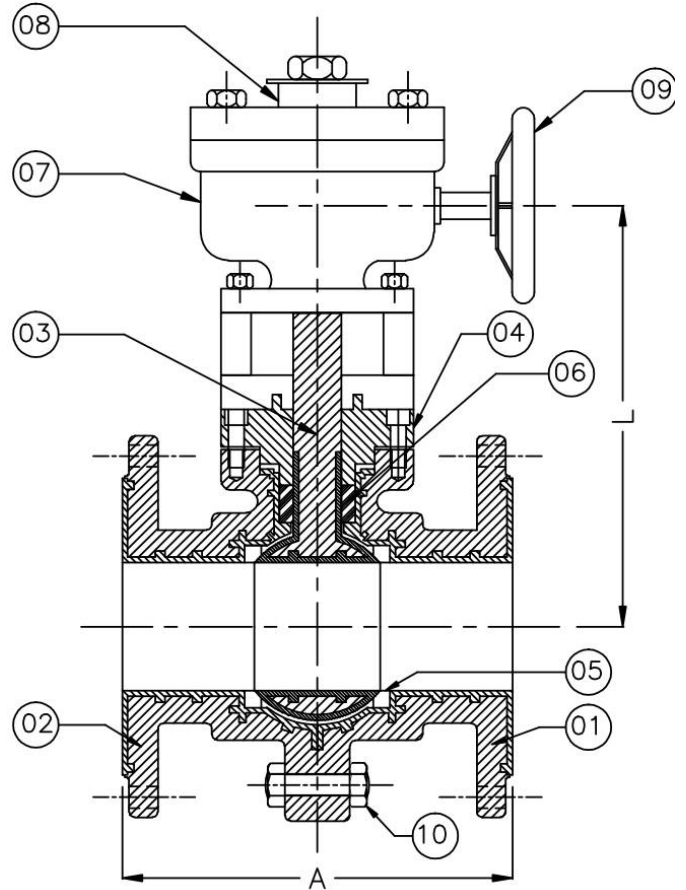

HSN CODE : 84818030

S. NO.	PART NAME	MATERIAL	TEST PRESSURE - HYD.	
01	BODY/FLANGE STANDARD <ul style="list-style-type: none"> ANSI CLASS 150# DIN PN 16 JIS CLASS 10k 	DI: ASTM A 395 CS: ASTM A 216 SS: ASTM A 182	METAL BODY WITHOUT LINING	28KG/CM ²
			METAL BODY WITH LINING	14KG/CM ²
02	LINNING THICKNESS 3.0mm MIN. 5.0mm MAX.	PFA-ASTM D3307 FEP-ASTM D2116 PVDF-ASTM D3222 P.P.-ASTM D2146	SPARK TEST	15 KV D.C.

BILL OF MATERIAL

S. NO.	PART NAME	MATERIAL
1	SIDE PIECE	GRADED CI/DI/WCB/SS + PFA/FEP/PVDF/PP LINED
2	SIDE PIECE	GRADED CI/DI/WCB/SS + PFA/FEP/PVDF/PP LINED
3	BALL/STEM	DI/WCB/SS + PFA/FEP/PVDF/PP LINED
4	GLAND	DI/WCB/SS
5	SEAT RING	PTFE
6	GLAND RING	PTFE
7	GEAR BOX	MS
8	INDICATOR	MS/SS
9	HAND WHEEL	MS/ SS FABRICATED
10	FASTENERS	MS/SS

CLIENT NAME. _____

DRAWING NO. _____

ORDER NO. _____

FLOW-TEK VALVES & CONTROLS INC

LINED PLUG VALVE

FACE TO FACE : BS 5158
ALL DIMENSIONS ARE IN mm

SIZE NB	A
15	108
20	118
25	127
32	146
40	165
50	178
65	190
80	203
100	229
125	248
150	267
200	292
250	330
300	356

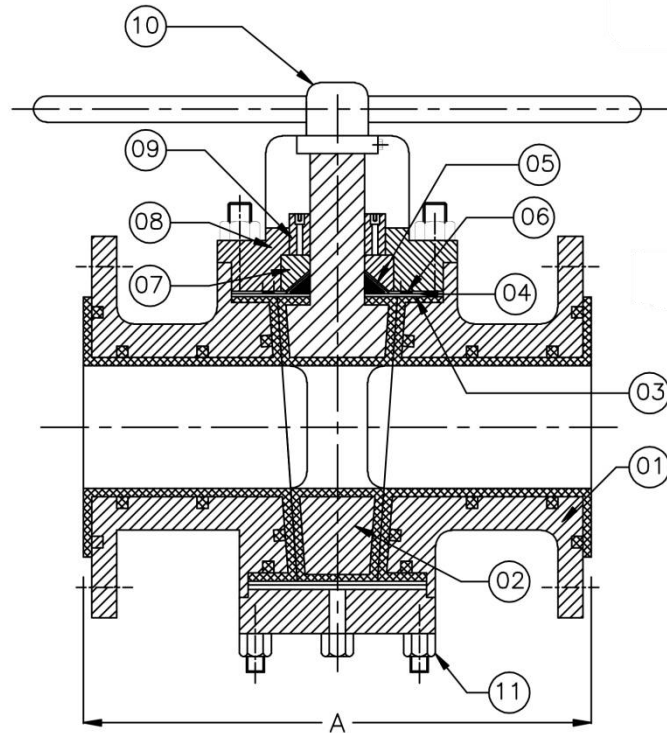

HSN CODE : 84818030

S. NO.	PART NAME	MATERIAL	TEST PRESSURE - HYD.	
01	BODY/FLANGE STANDARD • ANSI CLASS 150# • DIN PN 16 • JIS CLASS 10k	DI: ASTM A 395 CS: ASTM A 216 SS: ASTM A 182	METAL BODY WITHOUT LINING	28KG/CM ²
			METAL BODY WITH LINING	14KG/CM ²
02	LINNING THICKNESS 3.0mm MIN. 5.0mm MAX.	PFA-ASTM D3307 FEP-ASTM D2116 PVDF-ASTM D3222 P.P.-ASTM D2146	SPARK TEST	15 KV D.C.

BILL OF MATERIAL

S. NO.	PART NAME	MATERIAL
1	BODY	GRADED CI/DI/WCB/SS + PFA/FEP/PVDF/PP LINED
2	PLUG	GRADED CI/DI/WCB/SS + PFA/FEP/PVDF/PP LINED
3	DIAPHRAGM	PTFE
4	SHIM	MS/SS
5	WEDGE RING	PTFE
6	WASHER	PTFE
7	THRUST COLLAR	MS/SS
8	COVER PLATE	GRADED CI/DI/WCB/SS
9	ADJUSTING NUT	SS
10	CAP & HANDLE	MS
11	FASTENERS	MS/SS

CLIENT NAME. _____

DRAWING NO. _____

ORDER NO. _____

FLOW-TEK VALVES & CONTROLS INC

LINED DIAPHRAGM VALVE

FACE TO FACE : BS 5156
ALL DIMENSIONS ARE IN mm

SIZE	A	L	ØD
15 NB	114	95	70
20 NB	123	100	70
25 NB	133	115	95
32 NB	149	135	105
40 NB	165	154	115
50 NB	196	160	140
65 NB	222	180	165
80 NB	260	235	220
100 NB	311	260	240
125 NB	362	315	305
150 NB	412	370	370
200 NB	527	480	410
250 NB	641	540	580
300 NB	755	600	650

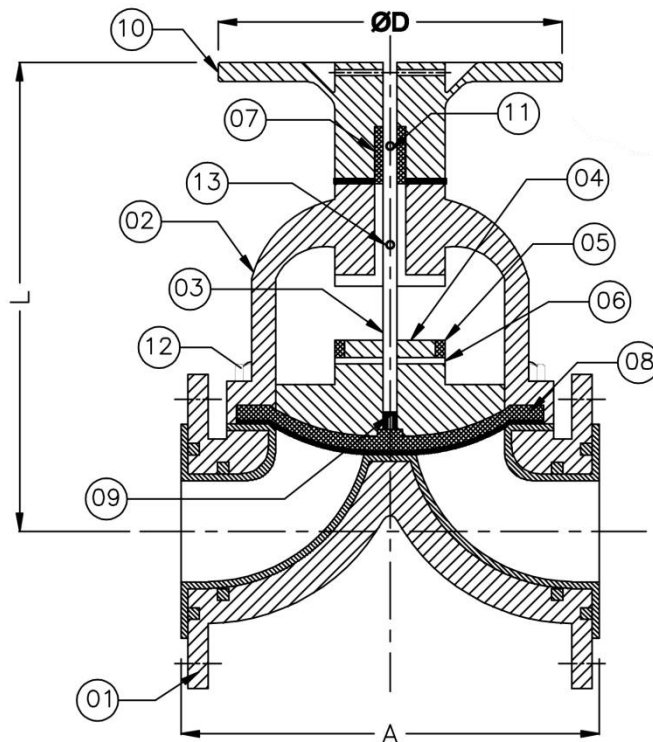

HSN CODE : 84818030

S. NO.	PART NAME	MATERIAL	TEST PRESSURE - HYD.	
01	BODY/FLANGE STANDARD • ANSI CLASS 150# • DIN PN 16 • JIS CLASS 10k	DI: ASTM A 395 CS: ASTM A 216 SS: ASTM A 182	METAL BODY WITHOUT LINING	28KG/CM ²
			METAL BODY WITH LINING	14KG/CM ²
02	LINING THICKNESS 3.0mm MIN. 5.0mm MAX.	PFA-ASTM D3307 FEP-ASTM D2116 PVDF-ASTM D3222 P.P.-ASTM D2146	SPARK TEST	15 KV D.C.

BILL OF MATERIAL

S. NO.	PART NAME	MATERIAL
1	BODY	GRADED CI/DI/WCB/SS + PFA/FEP/PVDF/PP LINED
2	BONNET	GRADED CI/DI/WCB/SS
3	SPINDLE	GRADED CI/DI/WCB/SS
4	COMPRESSOR	GRADED CI/DI/WCB/SS
5	COLLAR	CARBON STEEL
6	COMPRESSOR PIN	SS
7	BUSH	GUN METAL
8	DIAPHRAGM	PTFE WITH NEOPRENE RUBBER BACK UP
9	DIAPHRAGM STUD	BRASS
10	HANDLE WHEEL	GRADED CI/DI/WCB/SS
11	LOCK SCREW	SS
12	FASTENERS	MS/SS
13	GREASE NIPPLE	BRASS

CLIENT NAME. _____

DRAWING NO. _____

ORDER NO. _____

FLOW-TEK VALVES & CONTROLS INC

LINED BUTTERFLY VALVE

FACE TO FACE : BS 5155
ALL DIMENSIONS ARE IN mm

SIZE	A	B	C
50 NB	50	115	95
65 NB	55	130	110
80 NB	55	135	115
100 NB	60	145	120
125 NB	65	170	130
150 NB	65	180	140

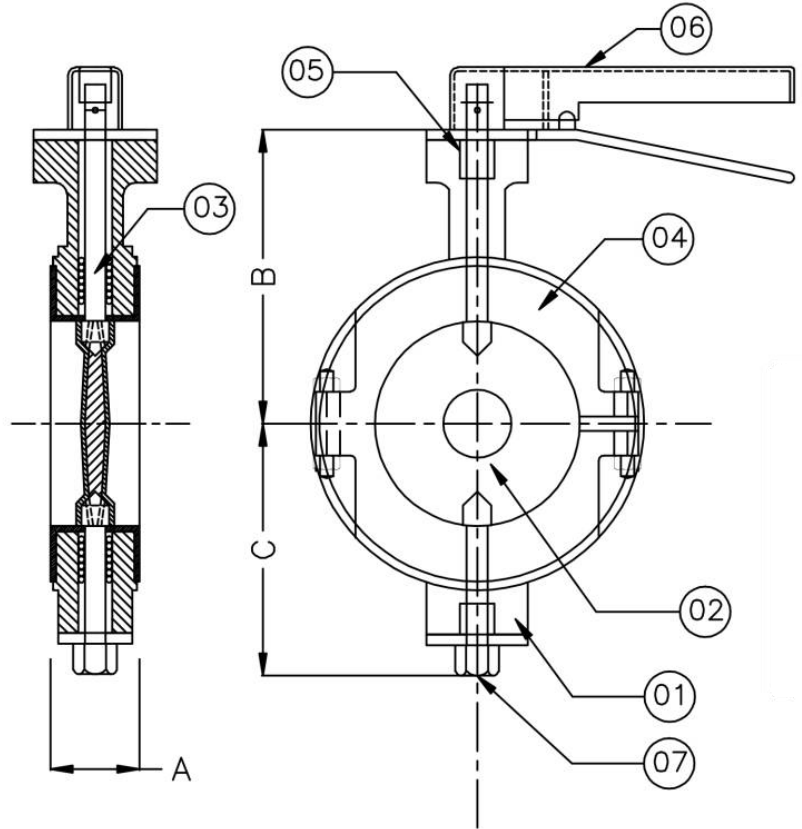

HSN CODE : 84818030

S. NO.	PART NAME	MATERIAL	TEST PRESSURE - HYD.	
01	BODY/FLANGE STANDARD • ANSI CLASS 150# • DIN PN 16 • JIS CLASS 10k	DI: ASTM A 395 CS: ASTM A 216 SS: ASTM A 182	METAL BODY WITHOUT LINING	28KG/CM ²
			METAL BODY WITH LINING	14KG/CM ²
02	LINNING THICKNESS 3.0mm MIN. 5.0mm MAX.	PFA-ASTM D3307 FEP-ASTM D2116 PVDF-ASTM D3222 P.P.-ASTM D2146	SPARK TEST	15 KV D.C.

BILL OF MATERIAL

S. NO.	PART NAME	MATERIAL
1	BODY	GRADED CI/DI/WCB/SS + PFA/FEP/PVDF/PP LINED
2	DISC	WCB/SS + PFA/FEP/PVDF/PP LINED
3	SPINDLE (INTEGRAL DISC)	WCB/SS + PFA/FEP/PVDF/PP LINED
4	SEAT	PFA/FEP/PTFE
5	BEARING BUSH	PTFE
6	LEVER	MS/SS FABRICATED
7	FASTENERS	MS/SS

CLIENT NAME. _____

DRAWING NO. _____

ORDER NO. _____

FLOW-TEK VALVES & CONTROLS INC

LINED GEAR OPERATED BUTTER FLY VALVE

FACE TO FACE : BS 5155
ALL DIMENSIONS ARE IN mm

SIZE	D	B	C	A
125 NB	200	380	130	60
150 NB	230	415	230	60
200 NB	250	460	185	65
250 NB	310	560	220	70
300 NB	330	580	280	80
350 NB	370	640	270	80
400 NB	400	680	300	100

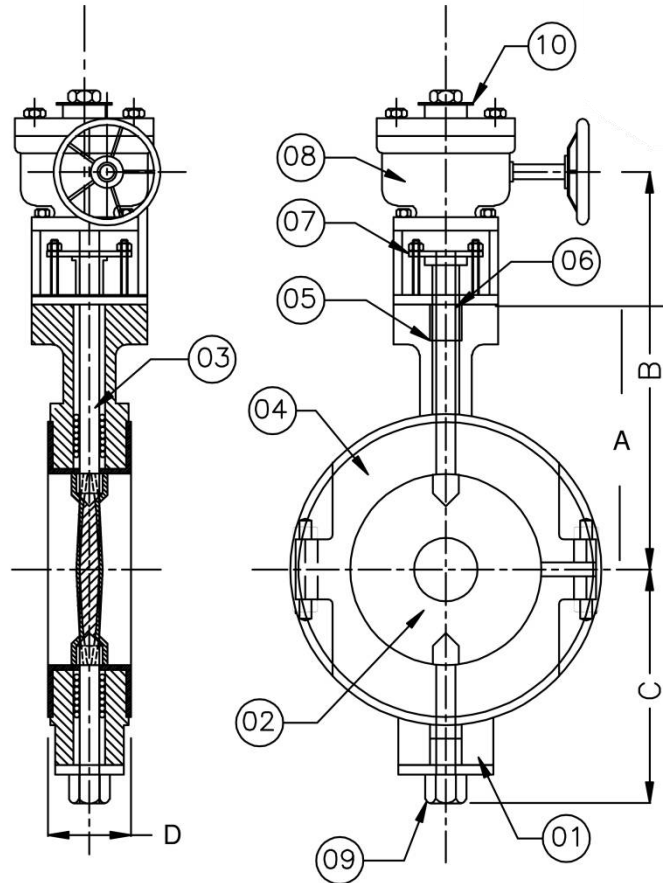

HSN CODE : 84818030

S. NO.	PART NAME	MATERIAL	TEST PRESSURE - HYD.	
01	BODY/FLANGE STANDARD • ANSI CLASS 150# • DIN PN 16 • JIS CLASS 10k	DI: ASTM A 395 CS: ASTM A 216 SS: ASTM A 182	METAL BODY WITHOUT LINING	28KG/CM ²
			METAL BODY WITH LINING	14KG/CM ²
02	LINING THICKNESS 3.0mm MIN. 5.0mm MAX.	PFA-ASTM D3307 FEP-ASTM D2116 PVDF-ASTM D3222 P.P.-ASTM D2146	SPARK TEST	15 KV D.C.

BILL OF MATERIAL

S. NO.	PART NAME	MATERIAL
1	BODY	GRADED DI/WCB/SS + PFA/FEP/PVDF/PP LINED
2	DISC	GRADED WCB/SS + PFA/FEP/PVDF/PP LINED
3	SPINDLE	GRADED MSI/WCB/SS + PFA/FEP/PVDF/PP LINED
4	SEAT	PTFE
5	BEARING BUSH	PTFE
6	GLAND BUSH	PTFE
7	GLAND FLANGE	PTFE
8	GEAR BOX	DI/MS FABRICATED
9	GEAR BOX WHEEL	MS/SS
10	FASTENERS	MS/SS

CLIENT NAME. _____

DRAWING NO. _____

ORDER NO. _____

FLOW-TEK VALVES & CONTROLS INC

LINED BALL CHECK VALVE

FACE TO FACE : BS 5351
ALL DIMENSIONS ARE IN mm

SIZE NB	A
15	108
20	118
25	127
32	146
40	165
50	178
65	190
80	203
100	229
125	248
150	267
200	292
250	533
300	610

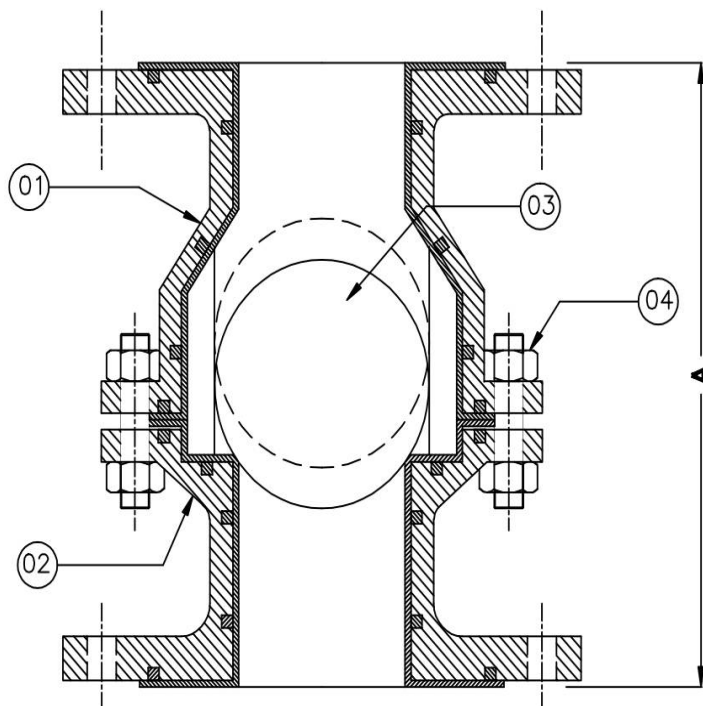

HSN CODE : 84818030

S. NO.	PART NAME	MATERIAL	TEST PRESSURE - HYD.	
01	BODY/FLANGE STANDARD <ul style="list-style-type: none"> ANSI CLASS 150# DIN PN 16 JIS CLASS 10k 	DI: ASTM A 395 CS: ASTM A 216 SS: ASTM A 182	METAL BODY WITHOUT LINING	28KG/CM ²
			METAL BODY WITH LINING	14KG/CM ²
02	LINING THICKNESS 3.0mm MIN. 5.0mm MAX.	PFA-ASTM D3307 FEP-ASTM D2116 PVDF-ASTM D3222 P.P.-ASTM D2146	SPARK TEST	15 KV D.C.

BILL OF MATERIAL

S. NO.	PART NAME	MATERIAL
1	SIDE PIECE	GRADED CI/DI/WCB/SS + PFA/FEP/PVDF/PP LINED
2	SIDE END PIECE	GRADED CI/DI/WCB/SS + PFA/FEP/PVDF/PP LINED
3	BALL	PTFE
4	FASTENERS	MS/SS

CLIENT NAME. _____

DRAWING NO. _____

ORDER NO. _____

FLOW-TEK VALVES & CONTROLS INC

LINED SWING CHECK VALVE

FACE TO FACE : As per Manufacturer's

SIZE	B	C	L	F
50 NB	30	101	43	62
65 NB	40	121	43	62
80 NB	50	133	46	62
100 NB	65	171	52	62
125 NB	88	195	54	62
150 NB	110	219	56	62
200 NB	135	275	60	62
250 NB	185	336	68	62
300 NB	230	406	78	62

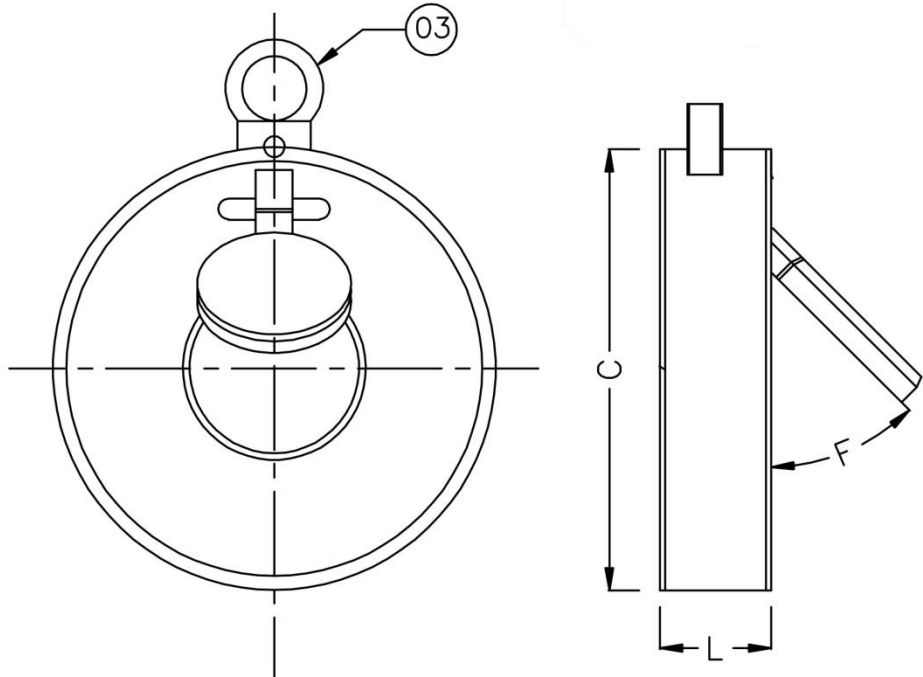

HSN CODE : 84818030

S. NO.	PART NAME	MATERIAL	TEST PRESSURE - HYD.	
01	BODY/FLANGE STANDARD • ANSI CLASS 150# • DIN PN 16 • JIS CLASS 10k	DI: ASTM A 395 CS: ASTM A 216 SS: ASTM A 182	METAL BODY WITHOUT LINING	28KG/CM ²
			METAL BODY WITH LINING	14KG/CM ²
02	LINING THICKNESS 3.0mm MIN. 5.0mm MAX.	PFA-ASTM D3307 FEP-ASTM D2116 PVDF-ASTM D3222 P.P.-ASTM D2146	SPARK TEST	15 KV D.C.

BILL OF MATERIAL

S. NO.	PART NAME	MATERIAL
1	BODY	GRADED CI/DI/WCB/SS + PFA/FEP/PVDF/PP LINED
2	BODY FLAP	GRADED CI/DI/WCB/SS + PFA/FEP/PVDF/PP LINED
3	LIFTING BOLT	MS/SS

CLIENT NAME. _____

DRAWING NO. _____

ORDER NO. _____

FLOW-TEK VALVES & CONTROLS INC

LINED SIGHT FLOW INDICATOR

ALL DIMENTION ARE IN mm

SIZE NB	F
15	108
20	118
25	127
32	140
40	165
50	178
65	190
80	203
100	229
125	254
150	267
200	292
250	330
300	356

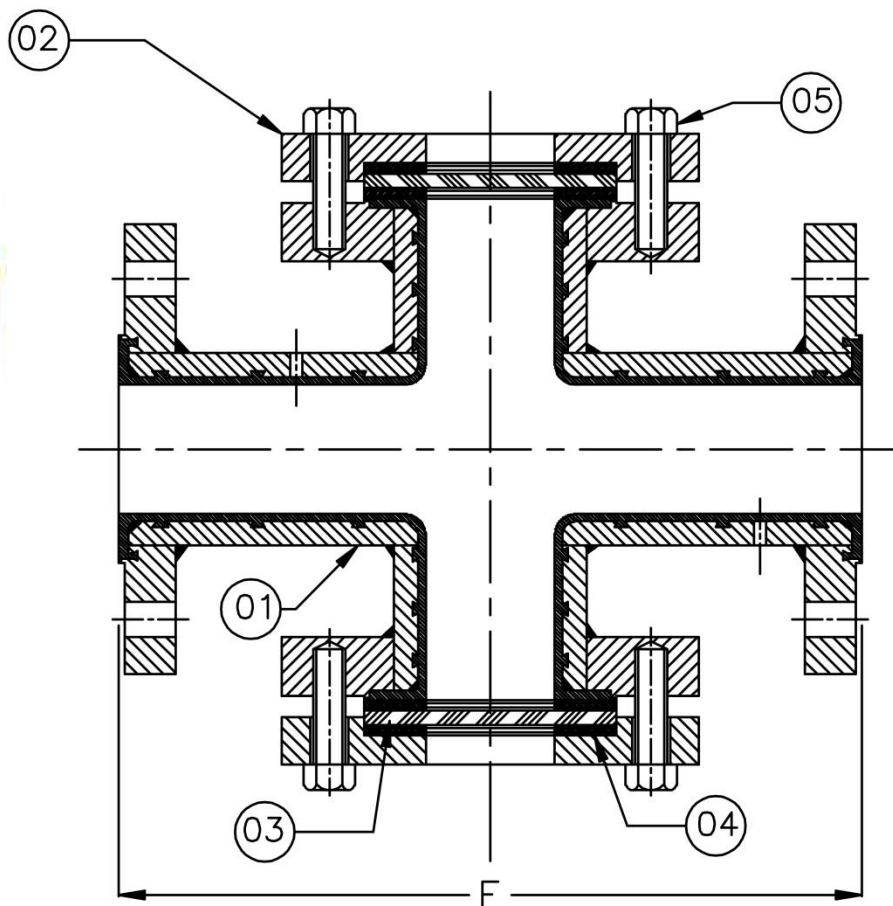

HSN CODE : 90262000

S. NO.	PART NAME	MATERIAL	TEST PRESSURE - HYD.	
01	BODY/FLANGE STANDARD <ul style="list-style-type: none"> ANSI CLASS 150# DIN PN 16 JIS CLASS 10k 	DI: ASTM A 395 CS: ASTM A 216 SS: ASTM A 182	METAL BODY WITHOUT LINING	28KG/CM ²
			METAL BODY WITH LINING	14KG/CM ²
02	LINNING THICKNESS 3.0mm MIN. 5.0mm MAX.	PFA-ASTM D3307 FEP-ASTM D2116 PVDF-ASTM D3222 P.P.-ASTM D2146	SPARK TEST	15 KV D.C.

BILL OF MATERIAL

S. NO.	PART NAME	MATERIAL
1	BODY	GRADED CI/DI/WCB/SS + PFA/FEP/PVDF/PP LINED
2	COVER	GRADED CI/DI/WCB/SS
3	INDICATOR	TOUGHENED GLASS
4	GASKET	PTFE
5	FASTENERS	MS/SS

CLIENT NAME. _____

DRAWING NO. _____

ORDER NO. _____

FLOW-TEK VALVES & CONTROLS INC

LINED TUBULAR SIGHT GLASS

ALL DIMENTION ARE IN mm

SIZE NB	F
15	108
20	118
25	127
32	140
40	165
50	178
65	190
80	203
100	229
125	254
150	267
200	292
250	330
300	356

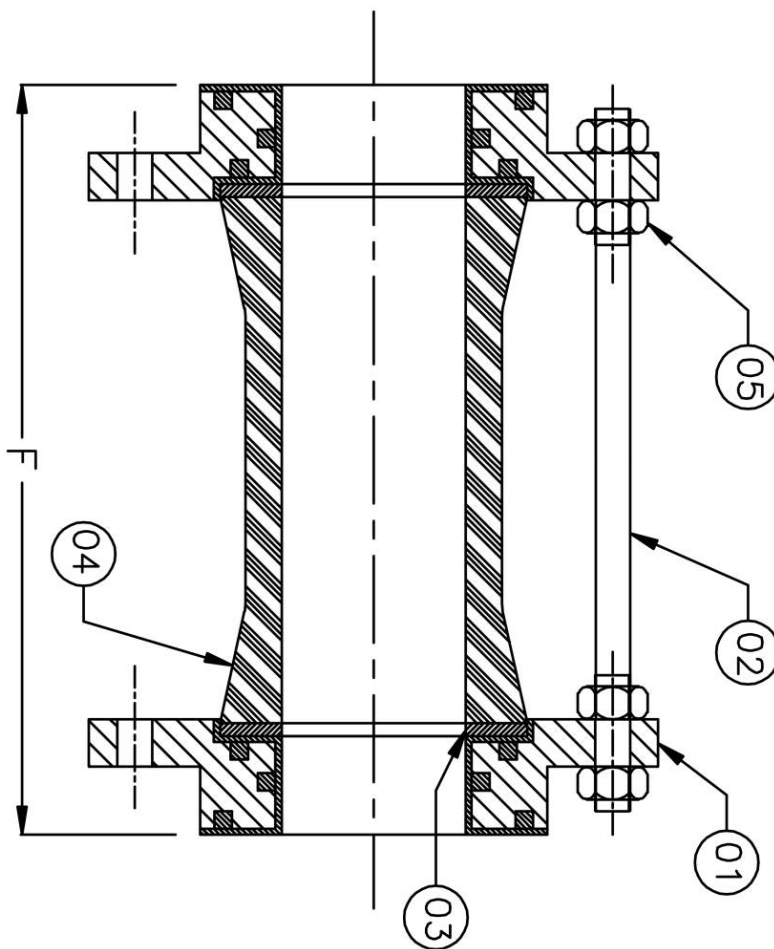

HSN CODE : 90262000

S. NO.	PART NAME	MATERIAL	TEST PRESSURE - HYD.	
01	BODY/FLANGE STANDARD <ul style="list-style-type: none"> ANSI CLASS 150# DIN PN 16 JIS CLASS 10k 	DI: ASTM A 395 CS: ASTM A 216 SS: ASTM A 182	METAL BODY WITHOUT LINING	28KG/CM ²
			METAL BODY WITH LINING	14KG/CM ²
02	LINNING THICKNESS 3.0mm MIN. 5.0mm MAX.	PFA-ASTM D3307 FEP-ASTM D2116 PVDF-ASTM D3222 P.P.-ASTM D2146	SPARK TEST	15 KV D.C.

BILL OF MATERIAL

S. NO.	PART NAME	MATERIAL
1	FLANGE	GRADED MS/SS + PFA/FEP/PVDF/PP LINED
2	ROD	GRADED MS/SS
3	GASKET	PTFE
4	INDICATOR	TOUGHENED GLASS
5	FASTENERS	MS/SS

CLIENT NAME. _____

DRAWING NO. _____

ORDER NO. _____

FLOW-TEK VALVES & CONTROLS INC

LINED Y STRAINER

ALL DIMENTION ARE IN mm

SIZE NB	F	H
15	140	105
20	150	115
25	165	125
32	180	145
40	203	160
50	228	165
65	280	200
80	318	280
100	370	305
125	415	360
150	470	410
200	600	590
250	700	680
300	800	750

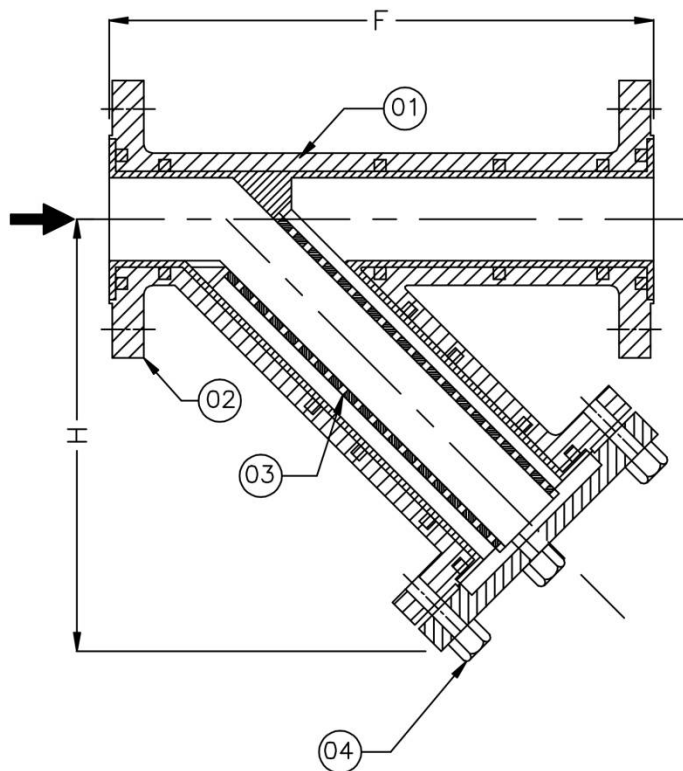

HSN CODE : 84211991

S. NO.	PART NAME	MATERIAL	TEST PRESSURE - HYD.	
01	BODY/FLANGE STANDARD <ul style="list-style-type: none"> ANSI CLASS 150# DIN PN 16 JIS CLASS 10k 	DI: ASTM A 395 CS: ASTM A 216 SS: ASTM A 182	METAL BODY WITHOUT LINING	28KG/CM ²
			METAL BODY WITH LINING	14KG/CM ²
02	LINNING THICKNESS 3.0mm MIN. 5.0mm MAX.	PFA-ASTM D3307 FEP-ASTM D2116 PVDF-ASTM D3222 P.P.-ASTM D2146	SPARK TEST	15 KV D.C.

BILL OF MATERIAL

S. NO.	PART NAME	MATERIAL
1	BODY	GRADED CI/DI/WCB/SS + PFA/FEP/PVDF/PP LINED
2	BODY FLANGE	GRADED CI/DI/WCB/SS + PFA/FEP/PVDF/PP LINED
3	FILTER ELEMENT	PTFE
4	FASTENERS	MS/SS

CLIENT NAME. _____

DRAWING NO. _____

ORDER NO. _____

FLOW-TEK VALVES & CONTROLS INC

LINED TEE STRAINER

ALL DIMENTION ARE IN mm

SIZE NB	F
15	140
20	150
25	165
32	180
40	203
50	228
65	280
80	318
100	370
125	415
150	470
200	600
250	700
300	800

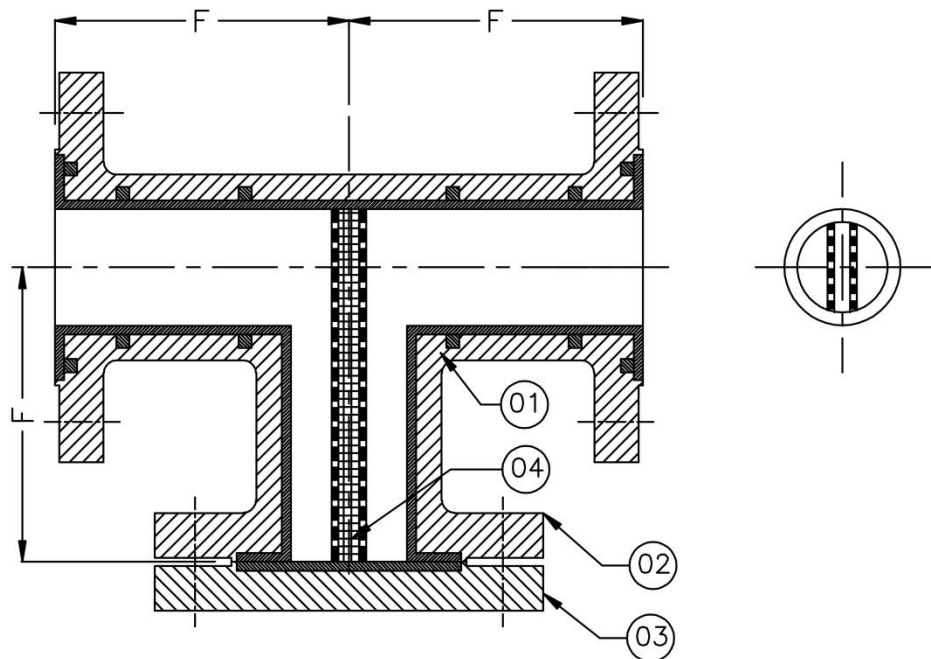

HSN CODE : 84211991

S. NO.	PART NAME	MATERIAL	TEST PRESSURE - HYD.	
01	BODY/FLANGE STANDARD <ul style="list-style-type: none"> ANSI CLASS 150# DIN PN 16 JIS CLASS 10k 	DI: ASTM A 395 CS: ASTM A 216 SS: ASTM A 182	METAL BODY WITHOUT LINING	28KG/CM ²
			METAL BODY WITH LINING	14KG/CM ²
02	LINNING THICKNESS 3.0mm MIN. 5.0mm MAX.	PFA-ASTM D3307 FEP-ASTM D2116 PVDF-ASTM D3222 P.P.-ASTM D2146	SPARK TEST	15 KV D.C.

BILL OF MATERIAL

S. NO.	PART NAME	MATERIAL
1	BODY	GRADED CI/DI/WCB/SS + PFA/FEP/PVDF/PP LINED
2	BODY FLANGE	GRADED CI/DI/WCB/SS + PFA/FEP/PVDF/PP LINED
3	FILTER ELEMENT	PTFE
4	FASTENERS	MS/SS

CLIENT NAME. _____

DRAWING NO. _____

ORDER NO. _____

FLOW-TEK VALVES & CONTROLS INC

LINED BUCKET STRAINER

ALL DIMENTION ARE IN mm

SIZE	F	H
15	140	145
20	150	155
25	165	170
32	184	189
40	203	208
50	228	223
65	280	285
80	318	323
100	370	375
125	420	425
150	470	475
200	600	605
250	700	705
300	800	805

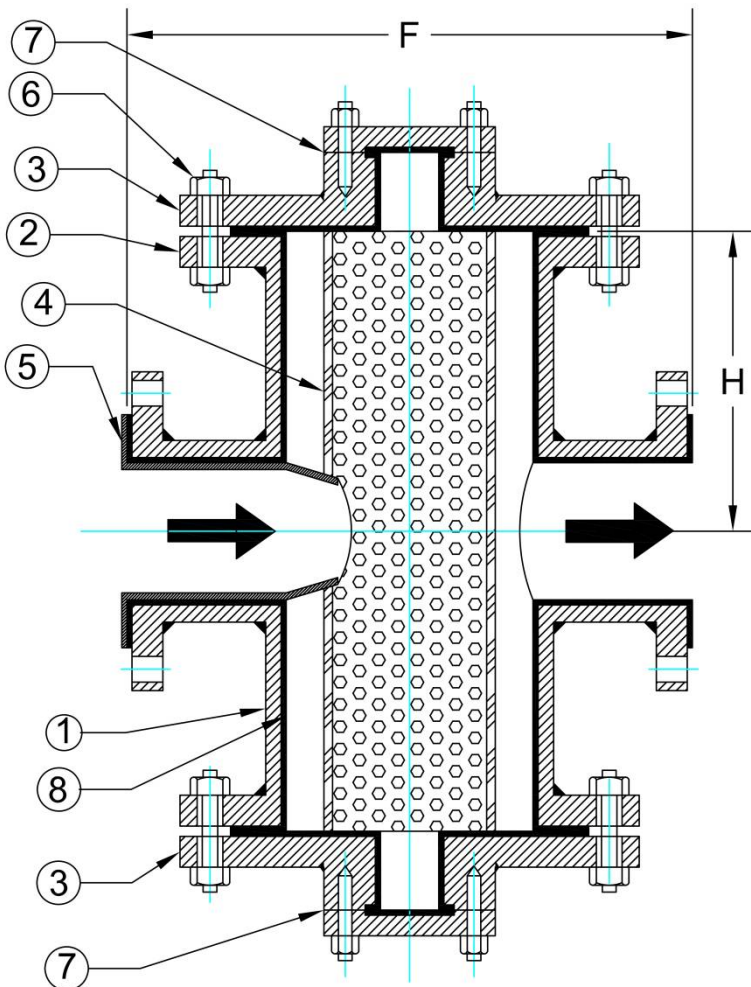

HSN CODE : 84211991

S. NO.	PART NAME	MATERIAL	TEST PRESSURE - HYD.	
01	BODY/FLANGE STANDARD • ANSI CLASS 150# • DIN PN 16 • JIS CLASS 10k	DI: ASTM A 395 CS: ASTM A 216 SS: ASTM A 182	METAL BODY WITHOUT LINING	28KG/CM ²
			METAL BODY WITH LINING	14KG/CM ²
02	LINNING THICKNESS 3.0mm MIN. 5.0mm MAX.	PFA-ASTM D3307 FEP-ASTM D2116 PVDF-ASTM D3222 P.P.-ASTM D2146	SPARK TEST	15 KV D.C.

BILL OF MATERIAL

S. NO.	PART NAME	MATERIAL
1	BODY	GRADED CI/DI/WCB/SS + PFA/FEP/PVDF/PP LINED
3	BODY FLANGE	GRADED CI/DI/WCB/SS + PFA/FEP/PVDF/PP LINED
4	FILTER ELEMENT	PTFE
6	FASTENERS	MS/SS

CLIENT NAME. _____

DRAWING NO. _____

ORDER NO. _____

FLOW-TEK VALVES & CONTROLS INC

LINED FLUSH BOTTOM VALVE

FACE TO FACE : As per
Manufacturer's Standard

SIZE	F	H
50x40	380	200
80x50	430	200
100x80	500	200
150x100	600	200
200x150	700	200

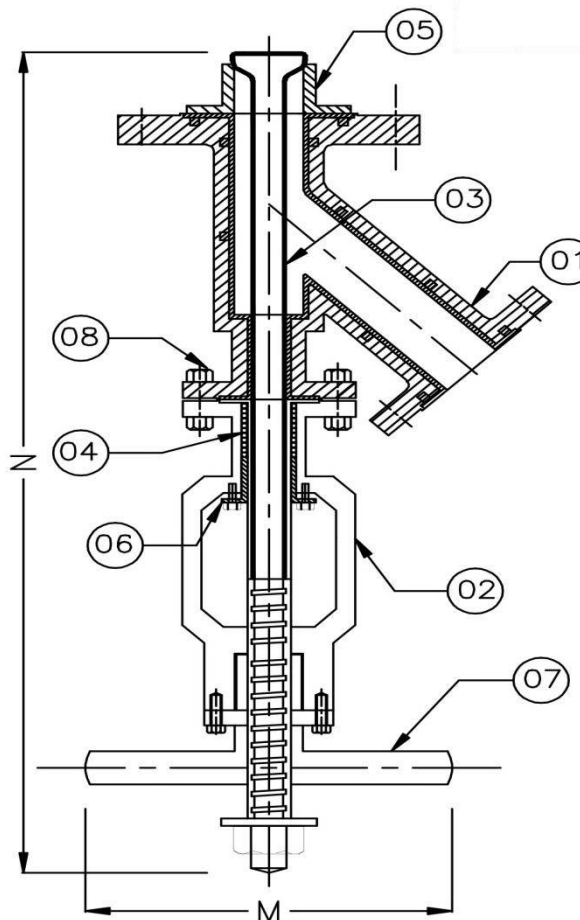

HSN CODE : 84818030

S. NO.	PART NAME	MATERIAL	TEST PRESSURE - HYD.	
01	BODY/FLANGE STANDARD • ANSI CLASS 150# • DIN PN 16 • JIS CLASS 10k	DI: ASTM A 395 CS: ASTM A 216 SS: ASTM A 182	METAL BODY WITHOUT LINING	28KG/CM ²
			METAL BODY WITH LINING	14KG/CM ²
02	LINNING THICKNESS 3.0mm MIN. 5.0mm MAX.	PFA-ASTM D3307 FEP-ASTM D2116 PVDF-ASTM D3222 P.P.-ASTM D2146	SPARK TEST	15 KV D.C.

BILL OF MATERIAL

S. NO.	PART NAME	MATERIAL
1	BODY	GRADED CI/DI/WCB/SS + PFA/FEP/PVDF/PP LINED
2	BONNET ASSEMBLY	GRADED CI/DI/WCB/SS + PFA/FEP/PVDF/PP LINED
3	SPINDLE	MS/WCB/SS + PFA/FEP/PVDF/PP LINED
4	GLAND	PTFE
5	VALVE SEAT	PTFE
6	GLAND CAP	DI/WCB/SS
7	WHEEL	MS
8	FASTENERS	MS/SS

CLIENT NAME. _____

DRAWING NO. _____

ORDER NO. _____

FLOW-TEK VALVES & CONTROLS INC

LINED PIPES AND FITTINGS GENERAL SPECIFICATION

Construction Of Material:—

Housing Material For Pipe Spool:—

Carbon Steel Pipe:—

Pipes material is seamless or welded, conforming to ASTM A106 Gr. B / ASTM A53, scheduled 40 or 20 wall thickness. For Nominal Diameter 1" to 8" scheduled 40 is used, scheduled 20 is used for diameter 10" to 12".

Stainless Steel Pipe:—

Pipes material is S.S.304, seamless ASTM A213, scheduled 40 wall thickness.

Flanges:—

Flange material is as per ASTM A105 & for DIN/BS 10 standard, flange is made from plate material IS 2062 Gr. A. Stainless Steel flange is as per ASTM A182.

Housing material for pipe fittings:—

As a standard, body material for all fitting is generally fabricated from pipe or alternatively Ductile Iron casting conform to ASTM A395, casting grade. Flange material ASTM A105.

Design Standard:—

PTFE/PFA/FEP Lined Pipes & fittings are which generally conform to ASTM F1545

Standard Resin Specification:—

PTFE : ASTM D 1457

PFA : ASTM D 3418

FEP : ASTM D 2116

PVDF : ASTM D 3222

P.P. : ASTM D 2146

Service Temperature:—

PTFE :Maximum Continues Service Temperature: 260°C
Melt Point : 327°C

PFA :Maximum Continues Service Temperature: 265°C
Melt Point : 305°C

FEP :Maximum Continues Service Temperature: 200°C
Melt Point : 260°C

PVDF :Maximum Continues Service Temperature: 140°C
Melt Point : 170°C

P.P. :Maximum Continues Service Temperature: 110°C
Melt Point : 200°C

FLOW-TEK VALVES & CONTROLS INC

LINED PIPES AND FITTINGS GENERAL SPECIFICATION

Chemical Inertness:—

PTFE/PFA/FEP are chemically inert to most off the all chemicals & solvents with the exception of molten alkali metals.

PTFE/PFA/FEP lined Pipes & Pipe fittings are used to convey, & are inert to, these chemicals: All acids including hydrofluoric, sulphuric & aqua regia, all caustic, all chlorides—organic & inorganic, all solvents, all bleach solution, all peroxides, all phenols & any combinations of above materials.

Combined with chemical inertness of PTFE/PFA/FEP is its unique non-stick property. thus a PTFE/PFA/FEP lined products eliminate or minimize the built up of deposits of the products which otherwise reduce flow & affect processing operations.

Product Inspection & testing:—

Hydrostatic Pressure:—

Body Test: 14Kg/Cm²

Electrostatic Pressure:—

Conduct The test with Non-destructive high voltage tester at an output voltage of 10,000V. When electric contact is made, a visible/audible spark or both occur at the probe if there is any defect.

Visual Inspection:—

All surfaces are free from blister, porosity or any other defect. any defect has to be repaired before shipment.

Storage & Transport:—

Each end of valves are protected by wooden plate or polypropylene plate so that products are capable to withstand normal handling during transport.

All the materials are supplied with export wooden case or card box packing depending upon the weight & mode of shipment.

FLOW-TEK VALVES & CONTROLS INC

INSTALLATION AND MAINTENANCE INSTRUCTIONS

FLANGE COVERS should not be removed until the flanges are ready to be bolted in to position or sealing faces may become damaged or distorted. If covers are removed for inspection purposes, they should be replaced immediately.

GASKETS are not required between fluoro-line piping components except where they are connected to a flange face of another material such as metal, glass, carbon, ceramic, reinforced plastic, etc. However, $\frac{3}{16}$ " thick resilient gaskets, preferably tapered, should be used to take up offset between cocked flanges at the ends of "sloped runs" or other connections where there is noticeable misalignment.

BOLTS should be only "snug tightened" with a wrench of appropriate length based on an average pulling of 50 pounds with one arm. The following bolt torques can be used as a guide.

Nominal Pipe Size	1"	1½"	2"	3"	4"	6"	8"	10"
Torques	10	15	25	40	30	60	75	70

Threads must be clean, well lubricated & washers used for correct torque readings if torque wrenches are used. Allowances must also be made for any "cold spring" in pipe. Tighten opposite bolts alternately & evenly. If a flange leak occurs & the bolts on the leaking side are properly torqued. DO NOT OVER TIGHTEN or permanent damage to the sealing face may result. Instead, loosen bolts on the opposite side by a half turn at a time, & then tighten bolts on the leaking side by the same amount. A gasket may be necessary if misalignment is excessive. If leak persists, remove bolts & examine sealing faces for scratches or dents which might provide a leakage path across the entire face. Any scratches or dents which do not exceed 20% of the liner thickness can be eliminated with fine abrasive cloth or paper. A gasket may also be necessary in some instances. If a leakage occurs after the system has been cycled at elevated temperature, bolts should be retorqued when system has cooled to room temperature. No further tightening should be necessary.

NO WELDING, BRAZING, SOLDERING OR FLAME CUTTING can be done close to the metal housing without adequate protection against excessive heat which can permanently damage the plastic liner.

SAFETY VENT HOLES should not be plugged with paint, cement, etc., since they release any gases trapped between liner & housing which at elevated temperature might otherwise collapse liner. They also warn of any accidental damage to liner before leakage becomes dangerous.

DO NOT ROTATE SCREWED FLANGES if a problem of bolt hole alignment develops, loosen bolts on as many upstream & downstream connections as necessary to obtain the required alignment, & then retighten all connections. Hairline cracks in tack welds of screwed flanges are of no consequence since these welds have no sealing or structural purpose, but simply lock the threads even when cracked.

SMOOTH METAL GUIDES $\frac{1}{32}$ " TO $\frac{1}{16}$ " thick should be employed to prevent damage to the sealing faces from interference when making terminal connections or installing individual sections in an existing line. This will facilitate sliding the sealing faces in to position.

DO NOT LOOSEN BOLTS nor remove sections while the system is above 65°C or sealing faces may distort & cause sealing difficulties on reinstallation. Flange covers or blind flanges should be immediately installed on any sections which are removed from the system to secure the sealing faces & protect them from damage while not in use.

FLOW-TEK VALVES & CONTROLS INC

LINED PIPE

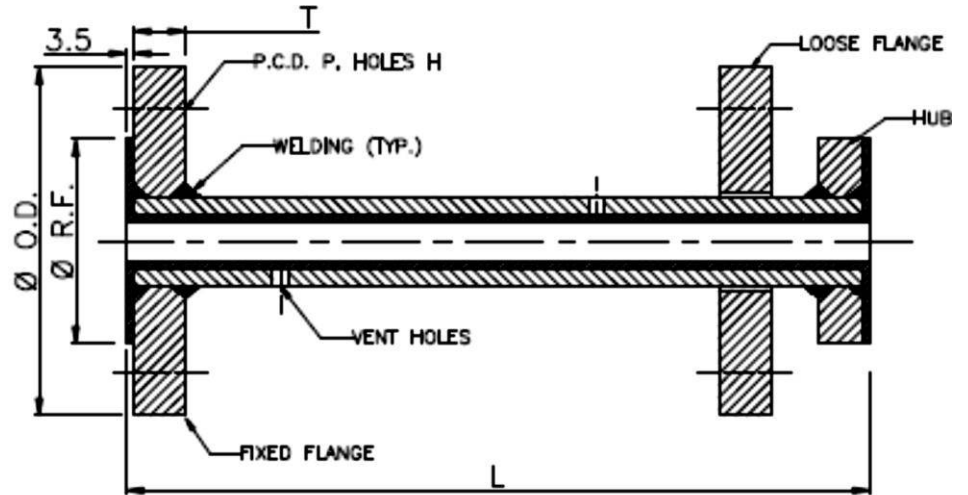

ALL DIMENSION ARE IN MM

S. NO.	PART NAME	MATERIAL	TEST PRESSURE - HYD.	
01	BODY/FLANGE STANDARD • ANSI CLASS 150# • DIN PN 16 • JIS CLASS 10k	DI: ASTM A 395 CS: ASTM A 216 SS: ASTM A 182	METAL BODY WITHOUT LINING	28KG/CM ²
02	LINNING THICKNESS 3.0mm MIN. 5.0mm MAX.	PFA-ASTM D3307 FEP-ASTM D2116 PVDF-ASTM D3222 P.P.-ASTM D2146	METAL BODY WITH LINING	14KG/CM ²
03	BODY FABRICATION	CS PIPE : ASTM A 106 SS PIPE : ASTM A 312 CS FLANGE : ASTM A 105 SS FLANGE : ASTM A 182	SPARK TEST	15 KV D.C.

HSN CODE : 73061919

LINED PIPE SIZE

SIZE	T	R.F	H holes x Ø	P (P.C.D.)	Ø O.D.	L MIN	L MAX
NB							
15	11.1	34.9	4 x Ø16	60.3	88.9	50	3000
20	12.7	42.9	4 x Ø16	69.8	98.4	50	3000
25	14.3	50.8	4 x Ø16	79.44	108	50	3000
32	15.7	63.5	4 x Ø16	88.9	117.3	100	3000
40	17.5	73	4 x Ø16	98.4	127	100	3000
50	19	92.1	4 x Ø19	120.6	152.4	100	3000
65	22.2	104.8	4 x Ø19	139.7	177.8	100	3000
80	23.8	127	4 x Ø19	152.4	190.5	100	3000
100	23.8	157.2	8 x Ø19	190.5	228.6	100	3000
125	23.8	185.7	8 x Ø19	215.9	254	100	3000
150	25.4	215.9	8 x Ø22.2	241.3	279.4	200	3000
200	28.8	269.9	8 x Ø22.2	298.4	342.9	200	3000
250	30.2	323.8	12 x Ø25.4	361.9	406.4	200	3000
300	31.7	381	12 x Ø25.4	431.8	482.6	200	3000

CLIENT NAME. _____

DRAWING NO. _____

ORDER NO. _____

FLOW-TEK VALVES & CONTROLS INC

LINED EQUAL & UNEQUAL TEE

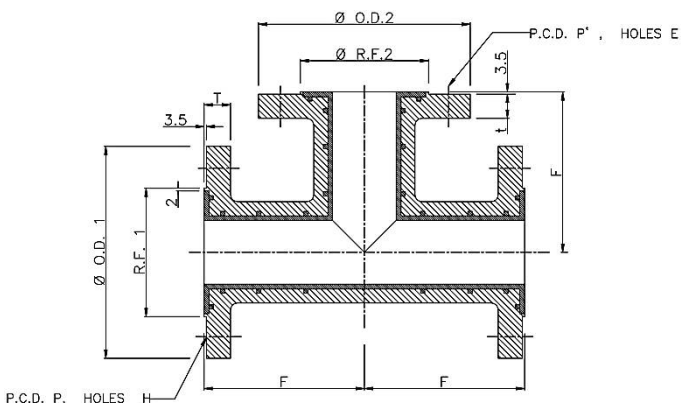

ALL DIMENSION ARE IN MM

HSN CODE : 73071190

LINED EQUAL TEE SIZE

SIZE	15 x 15 NB	20 x 20 NB	25 x 25 NB	32 x 32 NB	40 x 40 NB	50 x 50 NB	65 x 65 NB	80 x 80 NB	100 x 100 NB	125 x 125 NB	150 x 150 NB	200 x 200 NB	250 x 250 NB	300 x 300 NB
T	11.1	12.7	14.3	16	17.5	19	22.2	23.8	23.8	23.8	25.4	28.6	30.2	31.7
t	11.1	12.7	14.3	16	17.5	19	22.2	23.8	23.8	23.8	25.4	28.6	30.2	31.7
R.F.1	35.1	42.9	50.8	63.5	73.2	92	104.6	127	157.2	185.7	216	270	323.8	381
R.F.2	35.1	42.9	50.8	63.5	73.2	92	104.6	127	157.2	185.7	216	270	323.8	381
H (hole x Ø)	4 x Ø16	4 x Ø16	4 x Ø16	4 x Ø16	4 x Ø16	4 x Ø16	4 x Ø16	4 x Ø16	8 x Ø19	8 x Ø22.2	8 x Ø22.2	8 x Ø22.2	12 x Ø25.4	12 x Ø25.4
P	60.5	69.8	79.2	88.9	98.6	120.6	139.7	152.4	190.5	215.9	241.3	298.4	361.9	431.8
P'	60.5	69.8	79.2	88.9	98.6	120.6	139.7	152.4	190.5	215.9	241.3	298.4	361.9	431.8
Ø D1	88.9	98.4	108	117.3	127	152.4	177.8	190.5	228.6	254	279.4	342.9	406.4	482.2
Ø D2	88.9	98.4	108	117.3	127	152.4	177.8	190.5	228.6	254	279.4	342.9	406.4	482.2
E (thread x Ø)	4 x Ø16	4 x Ø16	4 x Ø16	4 x Ø16	4 x Ø16	4 x Ø16	4 x Ø16	4 x Ø16	8 x Ø19	8 x Ø22.2	8 x Ø22.2	8 x Ø22.2	12 x Ø25.4	12 x Ø25.4
F	65	75	89	95	102	115	127	140	165	190.5	203	228	280	305

LINED UNEQUAL TEE DIMENSIONS

SIZE	20 x 15	-----	-----	-----	-----
F	75	-----	-----	-----	-----
SIZE	25 x 15	25 x 20	-----	-----	-----
F	89	89	-----	-----	-----
SIZE	32 x 15	32 x 20	32 x 25	-----	-----
F	95	95	95	-----	-----
SIZE	40 x 15	40 x 20	40 x 25	40 x 32	-----
F	102	102	102	102	-----
SIZE	50 x 15	50 x 20	50 x 25	50 x 32	50 x 40
F	115	115	115	115	115
SIZE	65 x 20	65 x 25	65 x 32	65 x 40	65 x 50
F	127	127	127	127	127
SIZE	80 x 25	80 x 32	80 x 40	80 x 50	80 x 65
F	140	140	140	140	140
SIZE	100 x 32	100 x 40	100 x 50	100 x 65	100 x 80
F	165	165	165	165	165
SIZE	125 x 40	125 x 50	125 x 65	125 x 80	125 x 100
F	165	165	165	165	165
SIZE	150 x 50	150 x 65	150 x 80	150 x 100	150 x 125
F	203	203	203	203	203
SIZE	200 x 65	200 x 80	200 x 100	200 x 125	200 x 150
F	228	228	228	228	228
SIZE	250 x 80	250 x 100	250 x 125	250 x 150	250 x 200
F	280	280	280	280	280
SIZE	300 x 100	300 x 125	300 x 150	300 x 200	300 x 250
F	305	305	305	305	305

S. NO.	PART NAME	MATERIAL	TEST PRESSURE - HYD.	
01	BODY/FLANGE STANDARD • ANSI CLASS 150# • DIN PN 16 • JIS CLASS 10k	DI: ASTM A 395 CS: ASTM A 216 SS: ASTM A 182	METAL BODY WITHOUT LINING	28KG/CM ²
02	LINING THICKNESS 3.0mm MIN. 5.0mm MAX.	PFA-ASTM D3307 FEP-ASTM D2116 PVDF-ASTM D3222 P.P.-ASTM D2146	METAL BODY WITH LINING	14KG/CM ²
03	BODY FABRICATION	CS PIPE : ASTM A 106 SS PIPE : ASTM A 312 CS FLANGE : ASTM A 105 SS FLANGE : ASTM A 182	SPARK TEST	15 KV D.C.

CLIENT NAME. _____

DRAWING NO. _____

ORDER NO. _____

FLOW-TEK VALVES & CONTROLS INC

LINED 90° ELBOW

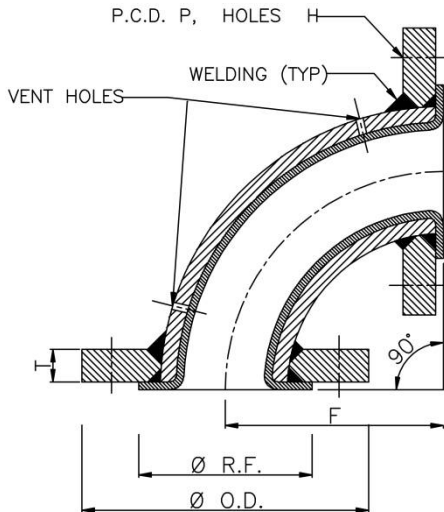

ALL DIMENSION ARE IN MM

HSN CODE : 73071190

LINED 90° ELBOW						
SIZE	T	R.F	H holes x Ø	P (P.C.D.)	Ø O.D.	F
NB						
15	11.1	34.9	4 x Ø16	60.3	88.9	65
20	12.7	42.9	4 x Ø16	69.8	98.4	75
25	14.3	50.8	4 x Ø16	79.44	108	89
32	16	63.5	4 x Ø16	88.9	117.3	95
40	17.5	73	4 x Ø16	98.4	127	102
50	19	92.1	4 x Ø19	120.6	152.4	115
65	22.2	104.8	4 x Ø19	139.7	177.8	127
80	23.8	127	4 x Ø19	152.4	190.5	140
100	23.8	157.2	8 x Ø19	190.5	228.6	165
125	23.8	185.7	8 x Ø22.2	215.9	254	190.5
150	25.4	215.9	8 x Ø22.2	190.5	279.4	203
200	28.8	269.9	8 x Ø22.2	298.4	342.9	228
250	30.2	323.8	12 x Ø25.4	361.9	406.4	280
300	31.7	381	12 x Ø25.4	431.8	482.6	305

S. NO.	PART NAME	MATERIAL	TEST PRESSURE – HYD.	
01	BODY/FLANGE STANDARD •ANSI CLASS 150# •DIN PN 16 •JIS CLASS 10k	DI: ASTM A 395 CS: ASTM A 216 SS: ASTM A 182	METAL BODY WITHOUT LINING	28KG/CM ²
02	LINING THICKNESS 3.0mm MIN. 5.0mm MAX.	PTFE-ASTM D1457 PFA-ASTM D3307 FEP-ASTM D2116 PVDF-ASTM D3222 P.P.-ASTM D2146	METAL BODY WITH LINING	14KG/CM ²
03	BODY FABRICATION	CS PIPE : ASTM A 106 SS PIPE : ASTM A 312 CS FLANGE : ASTM A 105 SS FLANGE : ASTM A 182	SPARK TEST	15 KV D.C.

CLIENT NAME. _____

DRAWING NO. _____

ORDER NO. _____

FLOW-TEK VALVES & CONTROLS INC

LINED 45° ELBOW

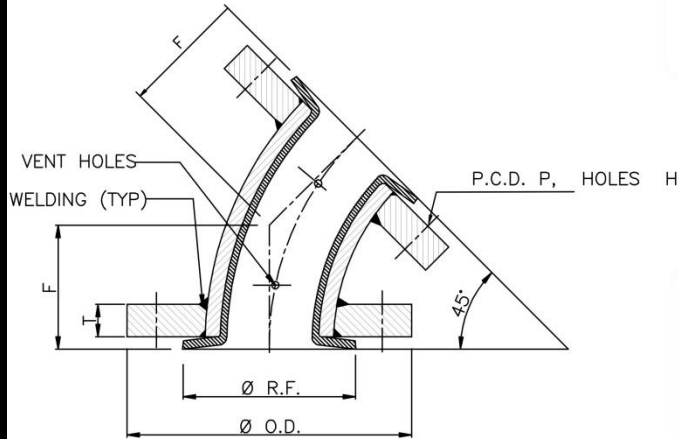

ALL DIMENSION ARE IN MM

HSN CODE : 73071190

LINED 45° ELBOW

SIZE	T	R.F	H holes x Ø	P (P.C.D.)	Ø O.D.	F
NB						
15	11.1	35.1	4 x Ø16	60.5	88.9	45
20	12.7	42.9	4 x Ø16	69.8	98.6	45
25	14.3	50.8	4 x Ø16	79.2	108	45
32	16	63.5	4 x Ø16	88.9	117.3	55
40	17.5	73.2	4 x Ø16	98.6	127	57
50	19	92	4 x Ø19	120.6	152.4	63
65	22.2	104.6	4 x Ø19	139.7	177.8	76
80	23.8	127	4 x Ø19	152.4	190.5	76
100	23.8	157.2	8 x Ø19	190.5	228.6	102
125	23.8	185.7	8 x Ø22.2	215.9	254	114
150	25.4	216	8 x Ø22.2	241.3	279.4	203
200	28.6	270	8 x Ø22.2	298.4	342.9	140
250	30.2	323.8	12 x Ø25.4	361.9	406.4	165
300	31.8	381	12 x Ø25.4	431.8	482.6	191

S. NO.	PART NAME	MATERIAL	TEST PRESSURE - HYD.	
01	BODY/FLANGE STANDARD • ANSI CLASS 150# • DIN PN 16 • JIS CLASS 10k	DI: ASTM A 395 CS: ASTM A 216 SS: ASTM A 182	METAL BODY WITHOUT LINING	28KG/CM ²
02	LINING THICKNESS 3.0mm MIN. 5.0mm MAX.	PTFE-ASTM D1457 PFA-ASTM D3307 FEP-ASTM D2116 PVDF-ASTM D3222 P.P.-ASTM D2146	METAL BODY WITH LINING	14KG/CM ²
03	BODY FABRICATION	CS PIPE : ASTM A 106 SS PIPE : ASTM A 312 CS FLANGE : ASTM A 105 SS FLANGE : ASTM A 182	SPARK TEST	15 KV D.C.

CLIENT NAME. _____

DRAWING NO. _____

ORDER NO. _____

FLOW-TEK VALVES & CONTROLS INC

LINED CONCENTRIC REDUCER

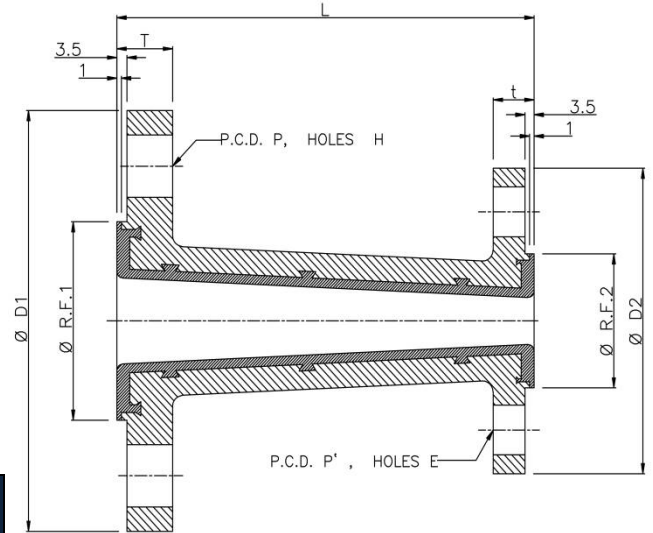

HSN CODE : 73071190

LINED CONCENTRIC REDUCER OVERALL LENGTH (L)

SIZE	20 x 15	----	----	----	----	----
L	114	----	----	----	----	----
SIZE	25 x 15	25 x 20	----	----	----	----
L	114	114	----	----	----	----
SIZE	32 x 15	32 x 20	32 x 25	----	----	----
L	114	114	114	----	----	----
SIZE	40 x 15	40 x 20	40 x 25	40 x 32	----	----
L	114	114	114	114	----	----
SIZE	50 x 15	50 x 20	50 x 25	50 x 32	50 x 40	----
L	127	127	127	127	127	----
SIZE	65 x 20	65 x 25	65 x 32	65 x 40	65 x 50	----
L	127	127	127	127	127	----
SIZE	80 x 25	80 x 32	80 x 40	80 x 50	80 x 65	----
L	152	152	152	152	152	----
SIZE	100 x 25	100 x 32	100 x 40	100 x 50	100 x 65	100 x 80
L	178	178	178	178	178	178
SIZE	125 x 32	125 x 40	125 x 50	125 x 65	125 x 80	125 x 100
L	203	203	203	203	203	203
SIZE	150 x 40	150 x 50	150 x 65	150 x 80	150 x 100	150 x 125
L	229	229	229	229	229	229
SIZE	200 x 50	200 x 65	200 x 80	200 x 100	200 x 125	200 x 150
L	279	279	279	279	279	279
SIZE	250 x 50	250 x 80	250 x 100	250 x 125	250 x 150	250 x 200
L	305	305	305	305	305	305
SIZE	300 x 80	300 x 100	300 x 125	300 x 150	300 x 200	300 x 250
L	365	365	365	365	365	365

ALL DIMENSION ARE IN MM

LINED CONCENTRIC REDUCER FLANGE DIMENSIONS

SIZE	T	R.F.	H (hole x Ø)	P	Ø D
15NB	11.1	35.1	4 x Ø16	60.5	88.9
20NB	12.7	42.9	4 x Ø16	69.8	98.6
25NB	14.3	50.8	4 x Ø16	79.2	108
32NB	16	63.5	4 x Ø16	88.9	117.3
40NB	17.5	73.2	4 x Ø16	98.6	127
50NB	19	92	4 x Ø19	120.6	152.4
65NB	22.2	104.6	4 x Ø19	139.7	177.8
80NB	23.8	127	4 x Ø19	152.4	190.5
100NB	23.8	157.2	8 x Ø19	190.5	228.6
125NB	23.8	185.7	8 x Ø22.2	215.9	254
150NB	25.4	216	8 x Ø22.2	241.3	279.4
200NB	28.6	270	8 x Ø22.2	298.4	342.9
250NB	30.2	323.8	12 x Ø25.4	361.9	406.4
300NB	31.8	381	12 x Ø25.4	431.8	482.6

S. NO.	PART NAME	MATERIAL	TEST PRESSURE - HYD.	
01	BODY/FLANGE STANDARD • ANSI CLASS 150# • DIN PN 16 • JIS CLASS 10k	DI: ASTM A 395 CS: ASTM A 216 SS: ASTM A 182	METAL BODY WITHOUT LINING	28KG/CM ²
02	LINING THICKNESS 3.0mm MIN. 5.0mm MAX.	PTFE-ASTM D1457 PFA-ASTM D3307 FEP-ASTM D2116 PVDF-ASTM D3222 P.P.-ASTM D2146	METAL BODY WITH LINING	14KG/CM ²
03	BODY FABRICATION	CS PIPE : ASTM A 106 SS PIPE : ASTM A 312 CS FLANGE : ASTM A 105 SS FLANGE : ASTM A 182	SPARK TEST	15 KV D.C.

CLIENT NAME. _____

DRAWING NO. _____

ORDER NO. _____

FLOW-TEK VALVES & CONTROLS INC

LINED ECCENTRIC REDUCER

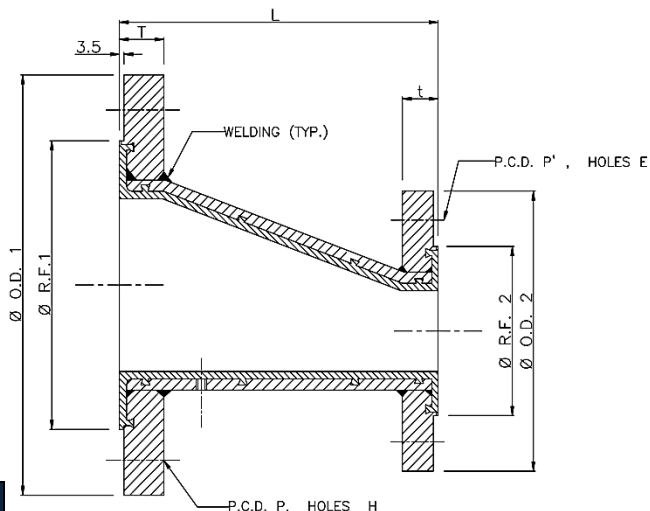

HSN CODE : 73071190

LINED ECCENTRIC REDUCER OVERALL LENGTH (L)

SIZE	20 x 15	----	----	----	----	----
L	114	----	----	----	----	----
SIZE	25 x 15	25 x 20	----	----	----	----
L	114	114	----	----	----	----
SIZE	32 x 15	32 x 20	32 x 25	----	----	----
L	114	114	114	----	----	----
SIZE	40 x 15	40 x 20	40 x 25	40 x 32	----	----
L	114	114	114	114	----	----
SIZE	50 x 15	50 x 20	50 x 25	50 x 32	50 x 40	----
L	127	127	127	127	127	----
SIZE	65 x 20	65 x 25	65 x 32	65 x 40	65 x 50	----
L	127	127	127	127	127	----
SIZE	80 x 20	80 x 25	80 x 32	80 x 40	80 x 50	80 x 65
L	152	152	152	152	152	152
SIZE	100 x 25	100 x 32	100 x 40	100 x 50	100 x 65	100 x 80
L	178	178	178	178	178	178
SIZE	125 x 32	125 x 40	125 x 50	125 x 65	125 x 80	125 x 100
L	203	203	203	203	203	203
SIZE	150 x 40	150 x 50	150 x 65	150 x 80	150 x 100	150 x 125
L	229	229	229	229	229	229
SIZE	200 x 50	200 x 65	200 x 80	200 x 100	200 x 125	200 x 150
L	279	279	279	279	279	279
SIZE	250 x 50	250 x 80	250 x 100	250 x 125	250 x 150	250 x 200
L	305	305	305	305	305	305
SIZE	300 x 80	300 x 100	300 x 125	300 x 150	300 x 200	300 x 250
L	365	365	365	365	365	365

ALL DIMENSION ARE IN MM

LINED ECCENTRIC REDUCER FLANGE DIMENSIONS

SIZE	T	R.F.	H (hole x Ø)	P	Ø D
15NB	11.1	35.1	4 x Ø16	60.5	88.9
20NB	12.7	42.9	4 x Ø16	69.8	98.6
25NB	14.3	50.8	4 x Ø16	79.2	108
32NB	16	63.5	4 x Ø16	88.9	117.3
40NB	17.5	73.2	4 x Ø16	98.6	127
50NB	19	92	4 x Ø19	120.6	152.4
65NB	22.2	104.6	4 x Ø19	139.7	177.8
80NB	23.8	127	4 x Ø19	152.4	190.5
100NB	23.8	157.2	8 x Ø19	190.5	228.6
125NB	23.8	185.7	8 x Ø22.2	215.9	254
150NB	25.4	216	8 x Ø22.2	241.3	279.4
200NB	28.6	270	8 x Ø22.2	298.4	342.9
250NB	30.2	323.8	12 x Ø25.4	361.9	406.4
300NB	31.8	381	12 x Ø25.4	431.8	482.6

S. NO.	PART NAME	MATERIAL	TEST PRESSURE - HYD.	
01	BODY/FLANGE STANDARD • ANSI CLASS 150# • DIN PN 16 • JIS CLASS 10k	DI: ASTM A 395 CS: ASTM A 216 SS: ASTM A 182	METAL BODY WITHOUT LINING	28KG/CM ²
02	LINNING THICKNESS 3.0mm MIN. 5.0mm MAX.	PTFE-ASTM D1457 PFA-ASTM D3307 FEP-ASTM D2116 PVDF-ASTM D3222 P.P.-ASTM D2146	METAL BODY WITH LINING	14KG/CM ²
03	BODY FABRICATION	CS PIPE : ASTM A 106 SS PIPE : ASTM A 312 CS FLANGE : ASTM A 105 SS FLANGE : ASTM A 182	SPARK TEST	15 KV D.C.

CLIENT NAME. _____

DRAWING NO. _____

ORDER NO. _____

FLOW-TEK VALVES & CONTROLS INC

LINED BLIND FLANGE

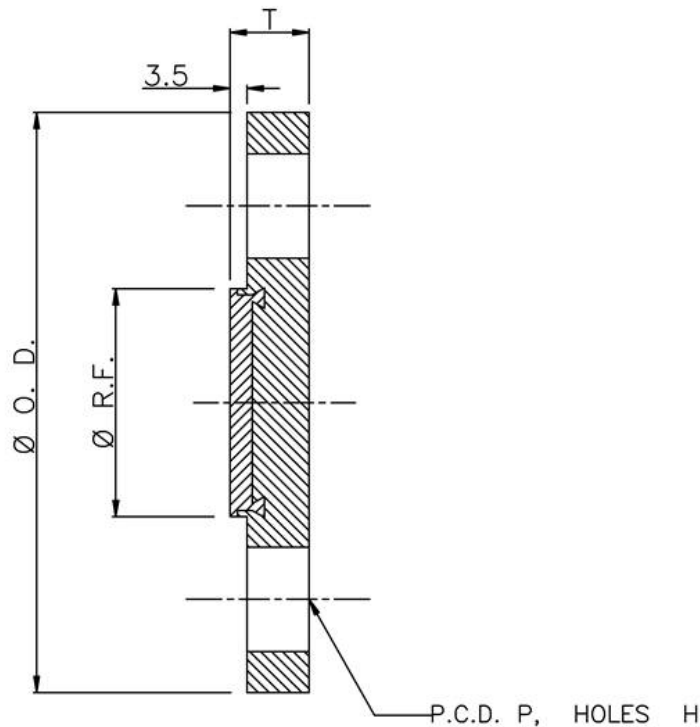

ALL DIMENSION ARE IN MM

HSN CODE : 73071190

SIZE	T	R.F.	H (hole x Ø)	P	Ø D
15NB	11.1	35.1	4 x Ø16	60.5	88.9
20NB	14.3	42.9	4 x Ø16	79.4	98.6
25NB	14.3	50.8	4 x Ø16	79.8	108
32NB	16	63.5	4 x Ø16	88.9	117.3
40NB	17.5	73.2	4 x Ø16	98.4	127
50NB	19	91.9	4 x Ø16	120.6	152.4
65NB	22.2	104.6	4 x Ø16	139.7	177.8
80NB	23.8	127	4 x Ø16	152.4	190.5
100NB	23.8	157.2	8 x Ø19	190.5	228.6
125NB	23.8	185.7	8 x Ø22.2	215.9	254
150NB	25.4	215.9	8 x Ø22.2	241.3	279.4
200NB	28.6	269.7	8 x Ø22.2	298.4	342.9
250NB	30.2	323.8	12 x Ø25.4	361.9	406.4
300NB	31.7	381	12 x Ø25.4	431.8	482.2

S. NO.	PART NAME	MATERIAL	TEST PRESSURE - HYD.	
01	BODY/FLANGE STANDARD • ANSI CLASS 150# • DIN PN 16 • JIS CLASS 10k	DI: ASTM A 395 CS: ASTM A 216 SS: ASTM A 182	METAL BODY WITHOUT LINING	28KG/CM ²
02	LINNING THICKNESS 3.0mm MIN. 5.0mm MAX.	PTFE-ASTM D1457 PFA-ASTM D3307 FEP-ASTM D2116 PVDF-ASTM D3222 P.P.-ASTM D2146	METAL BODY WITH LINING	14KG/CM ²
03	BODY FABRICATION	CS PIPE : ASTM A 106 SS PIPE : ASTM A 312 CS FLANGE : ASTM A 105 SS FLANGE : ASTM A 182	SPARK TEST	15 KV D.C.

CLIENT NAME. _____

DRAWING NO. _____

ORDER NO. _____

FLOW-TEK VALVES & CONTROLS INC

LINED CROSS

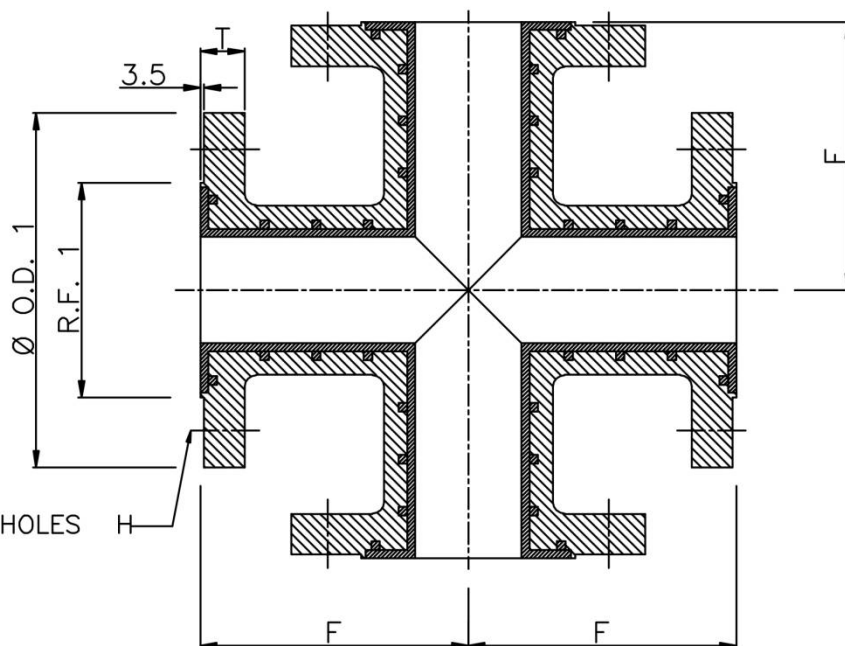

P.C.D. P, HOLES H

ALL DIMENSION ARE IN MM



HSN CODE : 73071190

SIZE	T	R.F.	H (hole x Ø)	P	Ø D	F
15NB	11.1	35.1	4 x Ø16	60.5	88.9	65
20NB	12.7	42.9	4 x Ø16	69.8	98.6	75
25NB	14.3	50.8	4 x Ø16	79.2	108	89
32NB	16	63.5	4 x Ø16	88.9	117.3	95
40NB	17.5	73.2	4 x Ø16	98.6	127	102
50NB	19	91.9	4 x Ø19	120.6	152.4	115
65NB	22.2	104.6	4 x Ø19	139.7	177.8	127
80NB	23.8	127	4 x Ø19	152.4	190.5	140
100NB	23.8	157.2	8 x Ø19	190.5	228.6	165
125NB	23.8	185.7	8 x Ø22.2	215.9	254	190.5
150NB	25.4	215.9	8 x Ø22.2	241.3	279.4	203
200NB	28.6	269.7	8 x Ø22.2	298.4	342.9	228
250NB	30.2	323.8	12 x Ø25.4	362	406.4	280
300NB	31.7	381	12 x Ø25.4	431.8	482.2	305

S. NO.	PART NAME	MATERIAL	TEST PRESSURE - HYD.	
01	BODY/FLANGE STANDARD <ul style="list-style-type: none"> ANSI CLASS 150# DIN PN 16 JIS CLASS 10k 	DI: ASTM A 395 CS: ASTM A 216 SS: ASTM A 182	METAL BODY WITHOUT LINING	28KG/CM ²
02	LINING THICKNESS 3.0mm MIN. 5.0mm MAX.	PTFE-ASTM D1457 PFA-ASTM D3307 FEP-ASTM D2116 PVDF-ASTM D3222 P.P.-ASTM D2146	METAL BODY WITH LINING	14KG/CM ²
03	BODY FABRICATION	CS PIPE : ASTM A 106 SS PIPE : ASTM A 312 CS FLANGE : ASTM A 105 SS FLANGE : ASTM A 182	SPARK TEST	15 KV D.C.

CLIENT NAME. _____

DRAWING NO. _____

ORDER NO. _____

FLOW-TEK VALVES & CONTROLS INC

LINED REDUCING FLANGE

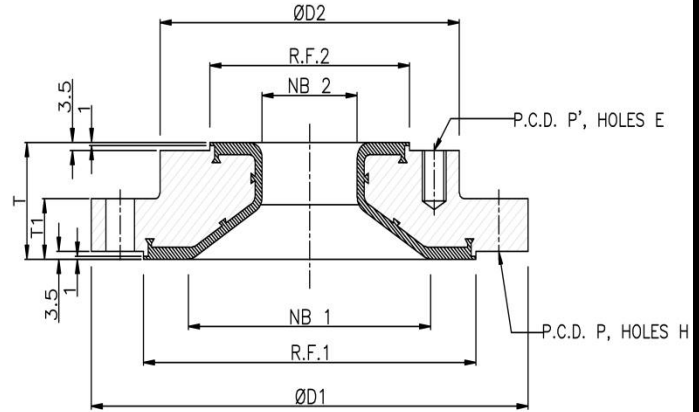

ALL DIMENSION ARE IN MM

HSN CODE : 73071190

LINED REDUCING FLANGE THICKNESS (T)

SIZE	20 x 15	----	----	----	----	----
T	50	----	----	----	----	----
SIZE	25 x 15	25 x 20	----	----	----	----
T	50	50	----	----	----	----
SIZE	32 x 15	32 x 20	32 x 25	----	----	----
T	50	50	50	----	----	----
SIZE	40 x 15	40 x 20	40 x 25	40 x 32	----	----
T	50	50	50	50	----	----
SIZE	50 x 15	50 x 20	50 x 25	50 x 32	50 x 40	----
T	50	50	50	50	50	----
SIZE	65 x 20	65 x 25	65 x 32	65 x 40	65 x 50	----
T	50	50	50	50	50	----
SIZE	80 x 20	80 x 25	80 x 32	80 x 40	80 x 50	80 x 65
T	50	50	50	50	50	50
SIZE	100 x 25	100 x 32	100 x 40	100 x 50	100 x 65	100 x 80
T	50	50	50	50	50	50
SIZE	125 x 32	125 x 40	125 x 50	125 x 65	125 x 80	125 x 100
T	50	50	50	50	50	50
SIZE	150 x 40	150 x 50	150 x 65	150 x 80	150 x 100	150 x 125
T	50	50	50	50	50	50
SIZE	200 x 50	200 x 65	200 x 80	200 x 100	200 x 125	200 x 150
T	50	50	50	50	50	50
SIZE	250 x 50	250 x 80	250 x 100	250 x 125	250 x 150	250 x 200
T	65	65	65	65	65	65
SIZE	300 x 80	300 x 100	300 x 125	300 x 150	300 x 200	300 x 250
T	65	65	65	65	65	65

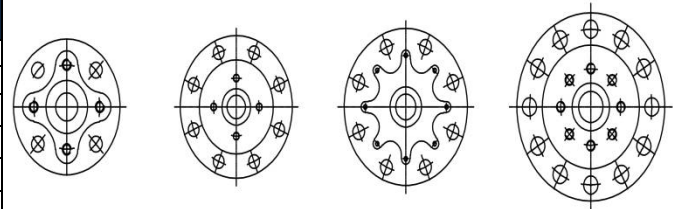

DRG. NO. 1

DRG. NO. 2

DRG. NO. 3

DRG. NO. 4

LINED REDUCING FLANGE DIMENSIONS

SIZE	T1	R.F.	H (hole x Ø)	P	Ø D	E thread x Ø
15NB	11.1	35.1	4 x Ø16	60.5	88.9	4-TAP x 12
20NB	12.7	42.9	4 x Ø16	69.8	98.6	4-TAP x 12
25NB	14.3	50.8	4 x Ø16	79.2	108	4-TAP x 12
32NB	16	63.5	4 x Ø16	88.9	117.3	4-TAP x 12
40NB	17.5	73.2	4 x Ø16	98.6	127	4-TAP x 12
50NB	19	91.9	4 x Ø19	120.6	152.4	4-TAP x 12
65NB	22.2	104.6	4 x Ø19	139.7	177.8	4-TAP x 16
80NB	23.8	127	4 x Ø19	152.4	190.5	4-TAP x 16
100NB	23.8	157.2	8 x Ø19	190.5	228.6	4-TAP x 16
125NB	23.8	185.7	8 x Ø22.2	215.9	254	4-TAP x 16
150NB	25.4	215.9	8 x Ø22.2	241.3	279.4	4-TAP x 16
200NB	28.6	269.7	8 x Ø22.2	298.4	342.9	4-TAP x 16
250NB	30.2	323.8	12 x Ø25.4	361.9	406.4	4-TAP x 20
300NB	31.8	381	12 x Ø25.4	431.8	482.2	4-TAP x 20

S. NO.	PART NAME	MATERIAL	TEST PRESSURE - HYD.	
			METAL BODY WITHOUT LINING	28KG/CM ²
01	BODY/FLANGE STANDARD • ANSI CLASS 150# • DIN PN 16 • JIS CLASS 10k	DI: ASTM A 395 CS: ASTM A 216 SS: ASTM A 182	METAL BODY WITH LINING	14KG/CM ²
02	LINING THICKNESS 3.0mm MIN. 5.0mm MAX.	PTFE-ASTM D1457 PFA-ASTM D3307 FEP-ASTM D2116 PVDF-ASTM D3222 P.P.-ASTM D2146	SPARK TEST	15 KV D.C.
03	BODY FABRICATION	CS PIPE : ASTM A 106 SS PIPE : ASTM A 312 CS FLANGE : ASTM A 105 SS FLANGE : ASTM A 182		

CLIENT NAME. _____

DRAWING NO. _____

ORDER NO. _____

FLOW-TEK VALVES & CONTROLS INC

LINED INSTRUMENT TEE

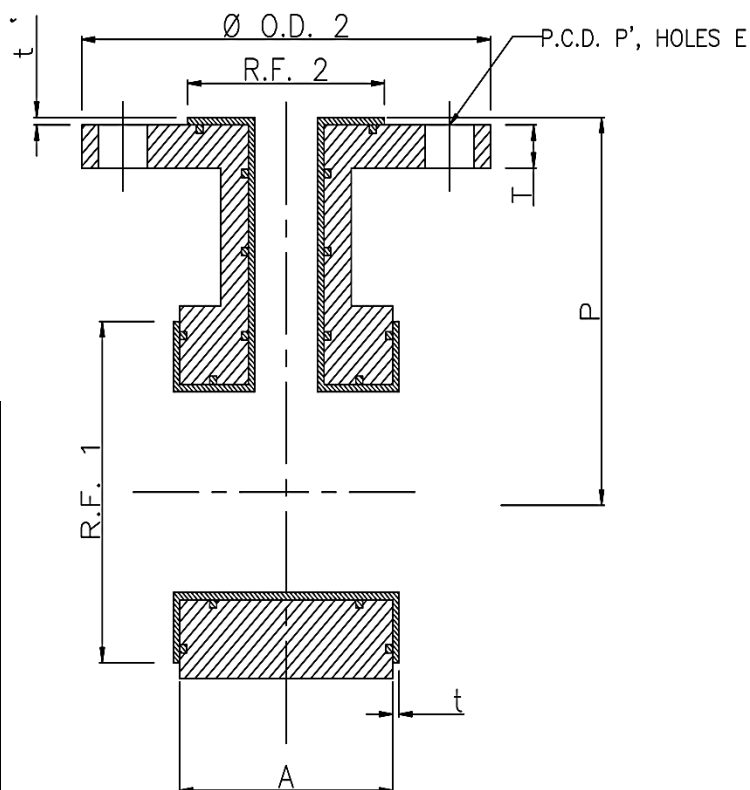

ALL DIMENSION ARE IN MM

HSN CODE : 73071190

LINED INSTRUMENT TEE (A)

SIZE	20 x 15	----	----	----	----
A	50	----	----	----	----
SIZE	25 x 15	25 x 20	----	----	----
A	50	50	----	----	----
SIZE	32 x 15	32 x 20	32 x 25	----	----
A	50	50	50	----	----
SIZE	40 x 15	40 x 20	40 x 25	40 x 32	----
A	50	50	50	50	----
SIZE	50 x 15	50 x 20	50 x 25	50 x 32	50 x 40
A	50	50	50	50	60
SIZE	65 x 20	65 x 25	65 x 32	65 x 40	65 x 50
A	50	50	50	60	70
SIZE	80 x 20	80 x 25	80 x 32	80 x 40	80 x 50
A	50	50	50	60	70
SIZE	100 x 20	100 x 25	100 x 32	100 x 40	100 x 50
A	50	50	50	60	70
SIZE	125 x 20	125 x 25	125 x 32	125 x 40	125 x 50
A	50	50	50	60	70
SIZE	150 x 20	150 x 25	150 x 32	150 x 40	150 x 50
A	50	50	50	60	70
SIZE	200 x 20	200 x 25	200 x 32	200 x 40	200 x 50
A	50	50	50	60	70
SIZE	250 x 20	250 x 25	250 x 32	250 x 40	250 x 50
A	50	50	50	60	70
SIZE	300 x 20	300 x 25	300 x 32	300 x 40	300 x 50
A	50	50	50	60	70

LINED INSTRUMENT TEE FLANGE DIMENSIONS

SIZE	T	R.F.2	H (hole x Ø)	P'	Ø O.D.2	R.F.1	P
15NB	11.1	35.1	4 x Ø16	60.5	88.9	---	65
20NB	14.3	50.8	4 x Ø16	79.4	98.6	43	75
25NB	14.3	50.8	4 x Ø16	79.8	108	50.8	89
32NB	16	63.5	4 x Ø16	88.9	117.3	63.5	95
40NB	17.5	73	4 x Ø16	98.4	127	73.2	102
50NB	19	92	4 x Ø19	120.6	152.4	91.9	115
65NB	----	----	----	----	----	104.6	127
80NB	----	----	----	----	----	124	140
100NB	----	----	----	----	----	157.2	165
125NB	----	----	----	----	----	185.7	190.5
150NB	----	----	----	----	----	215.9	203
200NB	----	----	----	----	----	269.7	228
250NB	----	----	----	----	----	323.8	280
300NB	----	----	----	----	----	381	305

S. NO.	PART NAME	MATERIAL	TEST PRESSURE - HYD.	
01	BODY/FLANGE STANDARD • ANSI CLASS 150# • DIN PN 16 • JIS CLASS 10k	DI: ASTM A 395 CS: ASTM A 216 SS: ASTM A 182	METAL BODY WITHOUT LINING	28KG/CM ²
02	LINNING THICKNESS 3.0mm MIN. 5.0mm MAX.	PTFE-ASTM D1457 PFA-ASTM D3307 FEP-ASTM D2116 PVDF-ASTM D3222 P.P.-ASTM D2146	METAL BODY WITH LINING	14KG/CM ²
03	BODY FABRICATION	CS PIPE : ASTM A 106 SS PIPE : ASTM A 312 CS FLANGE : ASTM A 105 SS FLANGE : ASTM A 182	SPARK TEST	15 KV D.C.

CLIENT NAME. _____

DRAWING NO. _____

ORDER NO. _____

FLOW-TEK VALVES & CONTROLS INC

SOLID SPACER

MATERIAL: 100% VIRGIN PTFE D1457

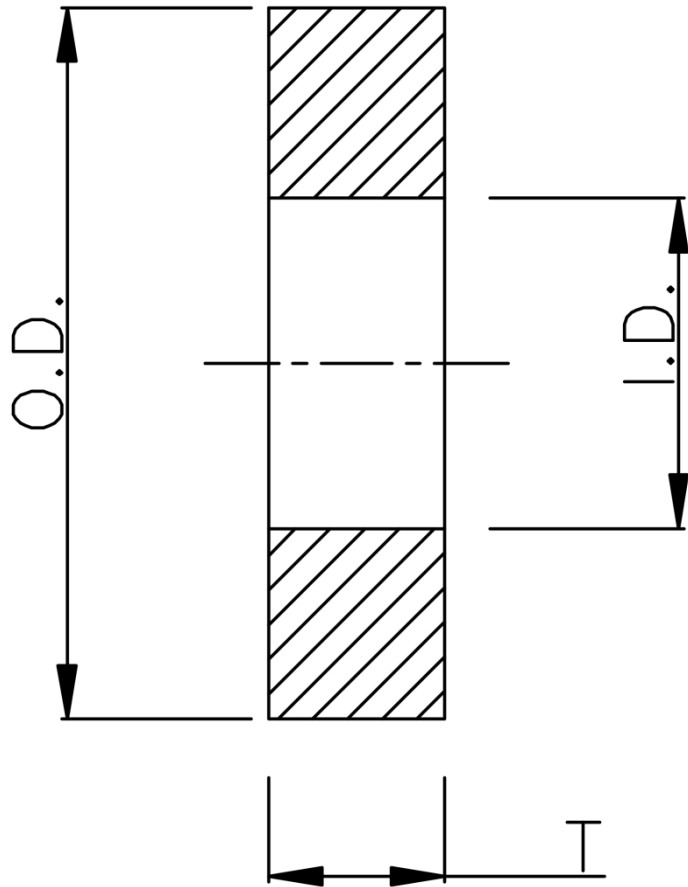

ALL DIMENSION ARE IN MM

HSN CODE : 39169090

SOLID SPACER DIMENSIONS			
SIZE	O.D.	I.D.	T
15NB	34.9	10	3 TO 50
20NB	42.9	15	3 TO 50
25NB	50.8	21	3 TO 50
32NB	62	28	3 TO 50
40NB	73	35	3 TO 50
50NB	92.1	46	3 TO 50
65NB	104.8	56	3 TO 50
80NB	127	72	3 TO 50
100NB	157.2	96	3 TO 50
125NB	187	121	3 TO 50
150NB	215.9	146	3 TO 50
200NB	269.9	194	3 TO 50
250NB	323.8	246	3 TO 50
300NB	381	294	3 TO 50

CLIENT NAME. _____

DRAWING NO. _____

ORDER NO. _____

FLOW-TEK VALVES & CONTROLS INC

LINED SPACER

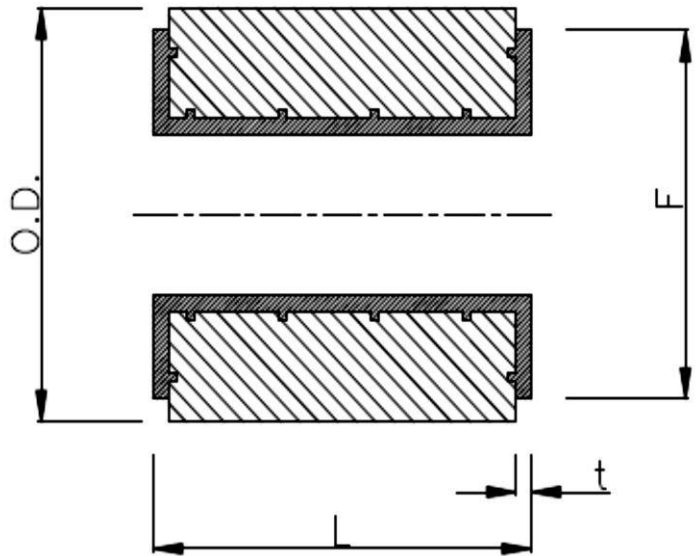
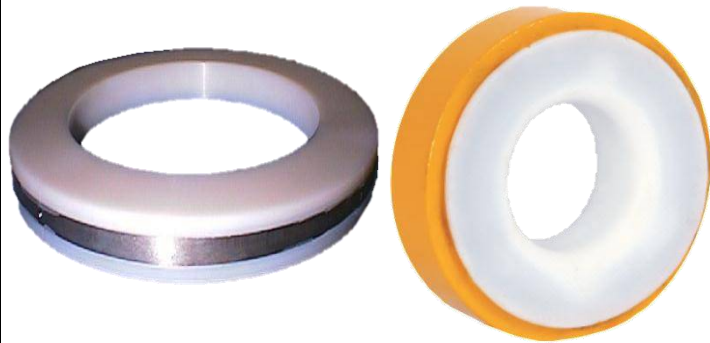

ALL DIMENSION ARE IN MM

HSN CODE : 73071190

SOLID SPACER DIMENSIONS

SIZE	O.D.	F	T	L
15NB	39.9	34.9	3.5	50 TO 100
20NB	47.9	42.9	3.5	50 TO 100
25NB	55.8	50.8	3.5	50 TO 100
32NB	67	62	3.5	50 TO 100
40NB	78	73	3.5	50 TO 100
50NB	97.1	92.1	3.5	50 TO 100
65NB	109.8	104.8	3.5	50 TO 100
80NB	132	127	3.5	50 TO 100
100NB	162.2	157.2	3.5	50 TO 100
125NB	192	187	3.5	50 TO 100
150NB	220.9	215.9	3.5	50 TO 100
200NB	274.9	269.9	3.5	50 TO 100
250NB	328.8	323.8	3.5	50 TO 100
300NB	386	381	3.5	50 TO 100

S. NO.	PART NAME	MATERIAL	TEST PRESSURE - HYD.	
01	BODY/FLANGE STANDARD <ul style="list-style-type: none"> • ANSI CLASS 150# • DIN PN 16 • JIS CLASS 10k 	DI: ASTM A 395 CS: ASTM A 216 SS: ASTM A 182	METAL BODY WITHOUT LINING	28KG/CM ²
02	LINNING THICKNESS 3.0mm MIN. 5.0mm MAX.	PTFE-ASTM D1457 PFA-ASTM D3307 FEP-ASTM D2116 PVDF-ASTM D3222 P.P.-ASTM D2146	METAL BODY WITH LINING	14KG/CM ²
03	BODY FABRICATION	CS PIPE : ASTM A 106 SS PIPE : ASTM A 312 CS FLANGE : ASTM A 105 SS FLANGE : ASTM A 182	SPARK TEST	15 KV D.C.

CLIENT NAME. _____

DRAWING NO. _____

ORDER NO. _____

FLOW-TEK VALVES & CONTROLS INC

LINED 45° LATERAL

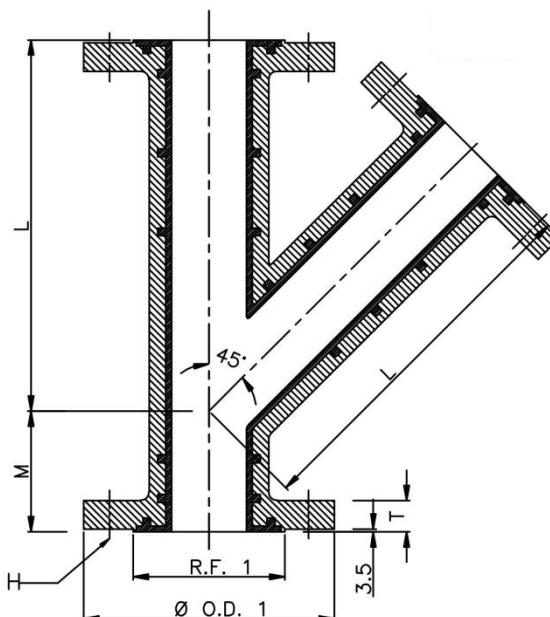

P.C.D. P, HOLES H

ALL DIMENSION ARE IN MM

HSN CODE : 73071190

SIZE	T	R.F.1	H (hole x Ø)	P (P.C.D)	Ø O.D.1	M	L
15NB	11.1	35.1	4 x Ø16	60.5	88.9	44.5	95.2
20NB	12.7	42.9	4 x Ø16	69.8	98.6	44.5	120.6
25NB	14.3	50.8	4 x Ø16	79.2	108	44.5	146.0
32NB	16	63.5	4 x Ø16	88.9	117.3	44.5	162
40NB	17.5	73.2	4 x Ø16	98.6	127	50.8	177.8
50NB	19	91.9	4 x Ø19	120.6	152.4	63.5	203.2
65NB	22.2	104.6	4 x Ø19	139.7	177.8	63.5	241.3
80NB	23.8	127	4 x Ø19	152.4	190.5	76.2	254
100NB	23.8	157.2	8 x Ø19	190.5	228.6	76.2	304.8
125NB	23.8	185.7	8 x Ø22.2	215.9	254	89	336.6
150NB	25.4	215.9	8 x Ø22.2	241.3	279.4	89	368.3
200NB	28.6	269.7	8 x Ø22.2	298.4	342.9	114.3	444.5
250NB	30.2	323.8	12 x Ø25.4	362	406.4	127	520.7
300NB	31.8	381	12 x Ø25.4	431.8	482.2	140	622.3

S. NO.	PART NAME	MATERIAL	TEST PRESSURE - HYD.	
01	BODY/FLANGE STANDARD • ANSI CLASS 150# • DIN PN 16 • JIS CLASS 10k	DI: ASTM A 395 CS: ASTM A 216 SS: ASTM A 182	METAL BODY WITHOUT LINING	28KG/CM ²
02	LINING THICKNESS 3.0mm MIN. 5.0mm MAX.	PTFE-ASTM D1457 PFA-ASTM D3307 FEP-ASTM D2116 PVDF-ASTM D3222 P.P.-ASTM D2146	METAL BODY WITH LINING	14KG/CM ²
03	BODY FABRICATION	CS PIPE : ASTM A 106 SS PIPE : ASTM A 312 CS FLANGE : ASTM A 105 SS FLANGE : ASTM A 182	SPARK TEST	15 KV D.C.

CLIENT NAME. _____

DRAWING NO. _____

ORDER NO. _____

FLOW-TEK VALVES & CONTROLS INC

EXPANSION BELLOW

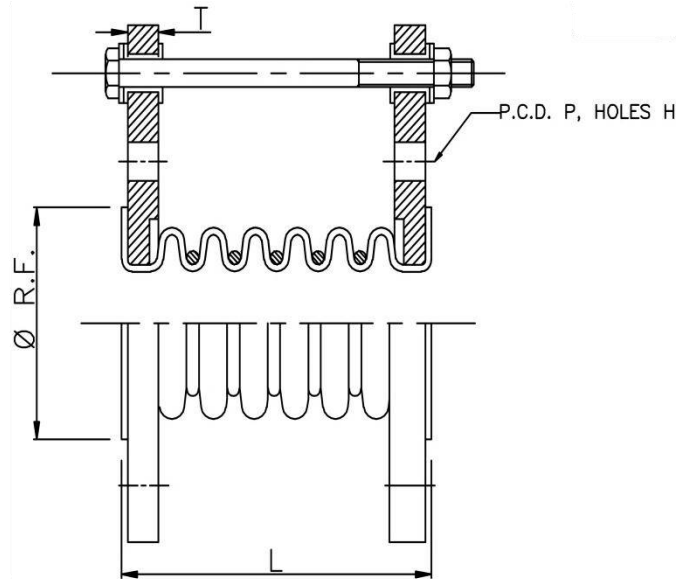

ALL DIMENSION ARE IN MM

HSN CODE : 39173920

SIZE	T	R.F.1	H (hole x Ø)	P (P.C.D)	Ø O.D.	2 CON.	3 CON.	5 CON.
15NB	11.1	35.1	4 x Ø16	60.5	88.9	40	51	74
20NB	12.7	42.9	4 x Ø16	69.8	98.6	40	51	74
25NB	14.3	50.8	4 x Ø16	79.2	108	50	61	83
32NB	16	63.5	4 x Ø16	88.9	117.3	55	68	94
40NB	17.5	73.2	4 x Ø16	98.6	127	61	76	105
50NB	19	91.9	4 x Ø19	120.6	152.4	69	78	115
65NB	22.2	104.6	4 x Ø19	139.7	177.8	69	86	120
80NB	23.8	127	4 x Ø19	152.4	190.5	73	95	137
100NB	23.8	157.2	8 x Ø19	190.5	228.6	94	96	138
125NB	23.8	185.7	8 x Ø22.2	215.9	254	81	104	150
150NB	25.4	215.9	8 x Ø22.2	241.3	279.4	89	112	160
200NB	28.6	269.7	8 x Ø22.2	298.4	342.9	97	123	175
250NB	30.2	323.8	12 x Ø25.4	362	406.4	99	128	186
300NB	31.8	381	12 x Ø25.4	431.8	482.2	102	133	194

S. NO.	PART NAME	MATERIAL	TEST PRESSURE - HYD.	
01	BODY/FLANGE STANDARD • ANSI CLASS 150# • DIN PN 16 • JIS CLASS 10k	DI: ASTM A 395 CS: ASTM A 216 SS: ASTM A 182	METAL BODY WITHOUT LINING	28KG/CM ²
02	LINNING THICKNESS 3.0mm MIN. 5.0mm MAX.	PTFE-ASTM D1457 PFA-ASTM D3307 FEP-ASTM D2116 PVDF-ASTM D3222 P.P.-ASTM D2146	METAL BODY WITH LINING	14KG/CM ²
03	BODY FABRICATION	CS PIPE : ASTM A 106 SS PIPE : ASTM A 312 CS FLANGE : ASTM A 105 SS FLANGE : ASTM A 182	SPARK TEST	15 KV D.C.

CLIENT NAME. _____

DRAWING NO. _____

ORDER NO. _____

FLOW-TEK VALVES & CONTROLS INC

LINED MANIFOLD

DESIGNE AVAILABLE SIZE 150NB TO 300NB.

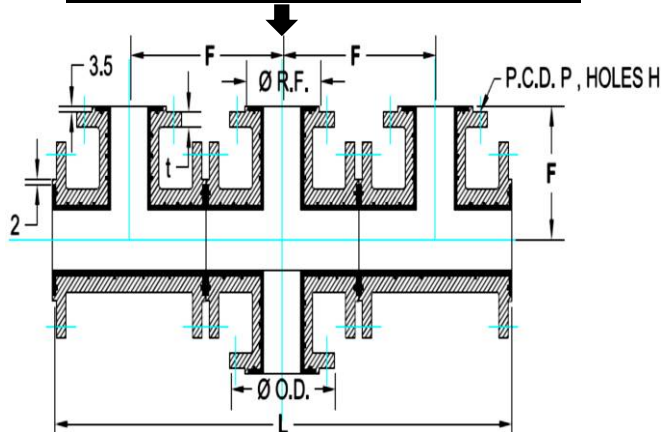

DESIGNE AVAILABLE SIZE 15NB TO 100NB.

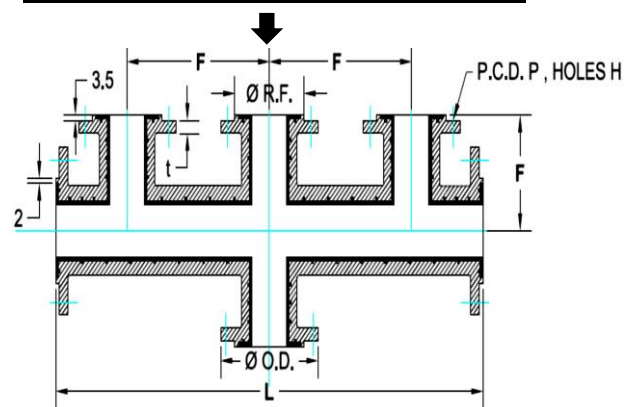

ALL DIMENSION ARE IN MM

HSN CODE : 73071190

LINED MANIFOLD SIZE

SIZE	t	R.F.	H (hole x Ø)	P	Ø D1	F	L
15 NB	11.1	34.9	4 x Ø 16	60.3	88.9	65	390
20 NB	12.7	42.9	4 x Ø 16	69.8	98.4	75	450
25 NB	14.3	50.8	4 x Ø 16	79.44	108	89	534
32 NB	16	63.5	4 x Ø 16	88.9	117.3	95	573
40 NB	17.5	73	4 x Ø 16	98.4	127	102	612
50 NB	19	92	4 x Ø 16	120.6	152.4	115	690
65 NB	22.2	105	4 x Ø 19	139.7	177.8	127	762
80 NB	23.8	127	4 x Ø 19	152.4	190.5	140	840
100 NB	23.8	157.2	8 x Ø 19	190.5	228.6	165	990
125 NB	23.8	185.7	8 x Ø 22.2	215.9	254	190.5	1104
150 NB	25.4	216	8 x Ø 22.2	241.3	279.4	203	1218
200 NB	28.6	270	8 x Ø 22.2	298.4	342.9	228	1368
250 NB	30.2	323.8	12 x Ø 25.4	361.9	406.4	280	1680
300 NB	31.7	381	12 x Ø 25.4	431.8	482.2	305	1830

S. NO.	PART NAME	MATERIAL	TEST PRESSURE - HYD.	
01	BODY/FLANGE STANDARD • ANSI CLASS 150# • DIN PN 16 • JIS CLASS 10k	DI: ASTM A 395 CS: ASTM A 216 SS: ASTM A 182	METAL BODY WITHOUT LINING	28KG/CM ²
02	LINING THICKNESS 3.0mm MIN. 5.0mm MAX.	PTFE-ASTM D1457 PFA-ASTM D3307 FEP-ASTM D2116 PVDF-ASTM D3222 P.P.-ASTM D2146	METAL BODY WITH LINING	14KG/CM ²
03	BODY FABRICATION	CS PIPE : ASTM A 106 SS PIPE : ASTM A 312 CS FLANGE : ASTM A 105 SS FLANGE : ASTM A 182	SPARK TEST	15 KV D.C.

CLIENT NAME. _____

DRAWING NO. _____

ORDER NO. _____

FLOW-TEK VALVES & CONTROLS INC

LINED IMPELLER AGITATOR

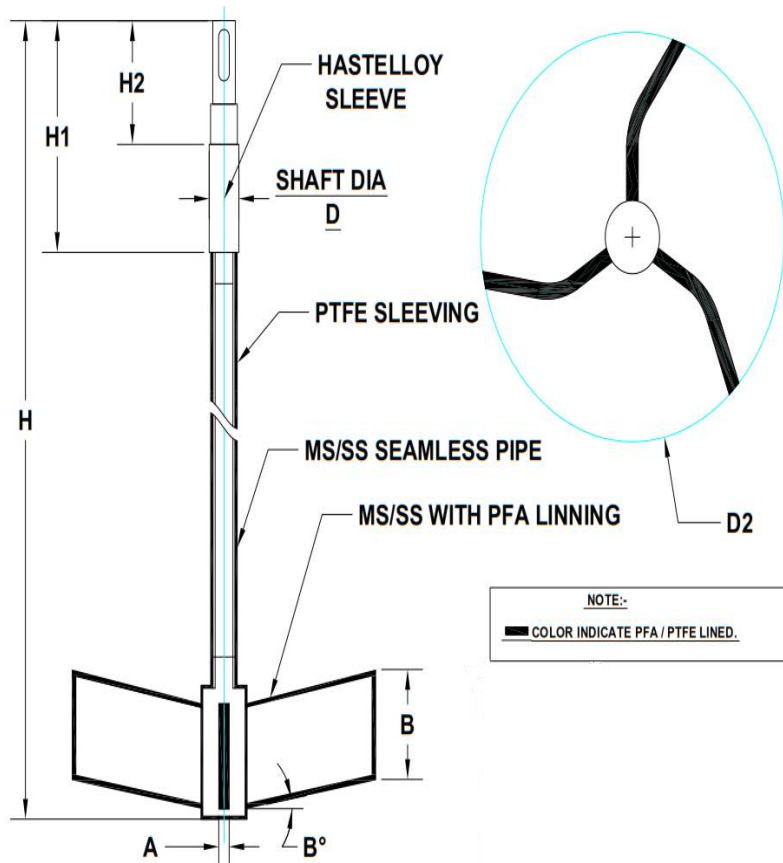

SR NO.	PART NAME	MATERIAL
1.	LINED IMPELLER AGITATOR	M.S. SS. 316
2.	LINNING THICKNESS 3.0 mm MAX. 5.0 mm MIN.	PFA PTFE
	SPARK TEST	15 KV D.C.

ALL DIMENSION ARE IN MM

HSN CODE : 73269099

LINED IMPELLER AGITATOR SIZE

CAP.	For MECH SEAL / S. BOX WITH SLEEV (DØ)	D2Ø	H	H1	(H2) For. MEACH SEAL	A	B
65L	40	300	970	380	282	20	100
105L	40	300	1170	380	282	20	100
165L	40	350	1290	380	282	20	100
255L	50	450	1450	410	312	20	100
405L	50	500	1655	410	312	20	100
505L	60	600	1556	420	312	20	100
635L	60	600	1720	420	312	20	100
1005L	60	700	1970	420	312	25	125
1605L	80	850	2285	475	357	25	125
2005L	80	850	2485	475	357	25	125
2505L	80	950	2540	475	357	25	125
3005L	80	950	2695	475	357	25	125
4005L	80	1100	2980	475	357	25	125
5005L	100	1100	3095	540	422	25	125
6305L	100	1100	3595	540	422	25	125
8005L	100	1100	3745	540	422	25	125
10005L	125	1250	4040	630	422	25	125
12505L	125	1250	4640	630	422	25	125

CLIENT NAME. _____

DRAWING NO. _____

ORDER NO. _____

FLOW-TEK VALVES & CONTROLS INC

LINED ANCHOR AGITATOR

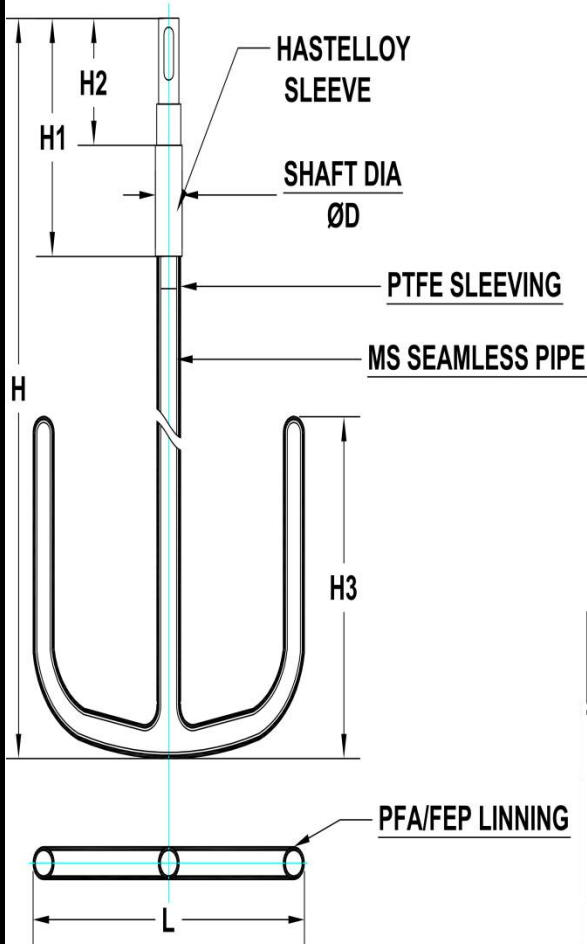

NOTE:-
 ■ COLOR INDICATE FEP/PFA LINED.
 DATE: 16/09/2016



ALL DIMENSION ARE IN MM

SR NO.	PART NAME	MATERIAL
1.	LINED ANCHOR AGITATOR	M.S. SS. 316
2.	LINNING THICKNESS 3.0 mm MAX. 5.0 mm MIN.	PFA PTFE
SPARK TEST		15 KV D.C.

HSN CODE : 73269099

LINED ANCHOR AGITATOR SIZE

CAP.	For MECH SEAL / S. BOX WITH SLEEV (DØ)	H	H1	(H2) For. MEACH SEAL	H3	L	AØ	BØ
65L	40	985	380	282	220	420	60	42
105L	40	1185	380	282	320	420	60	42
165L	40	1300	380	282	380	500	60	42
255L	50	1460	410	312	450	600	76	60
405L	50	1680	410	312	520	700	76	60
505L	60	1586	420	312	500	880	76	76
635L	60	1750	420	312	660	880	76	76
1005L	60	1990	420	312	790	1060	90	90
1605L	80	2300	475	357	940	1250	114	114
2005L	80	2500	475	357	940	1250	114	114
2505L	80	2555	475	357	1080	1440	114	114
3005L	80	2710	475	357	1080	1440	114	114
4005L	100	3085	540	422	1220	1630	140	140
5005L	100	3125	540	422	1150	1810	140	140
6305L	100	3625	540	422	1360	1810	140	140

CLIENT NAME. _____

DRAWING NO. _____

ORDER NO. _____

FLOW-TEK VALVES & CONTROLS INC

LINED THERMOWELL

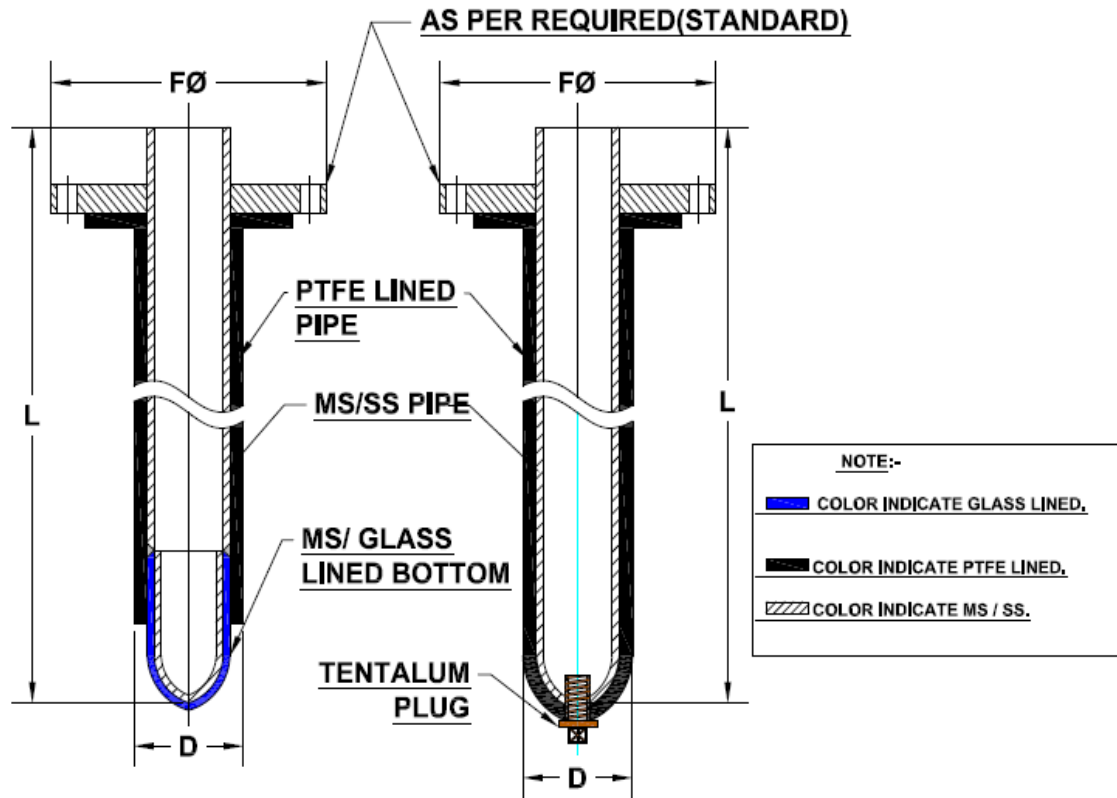

ALL DIMENSION ARE IN MM

SR NO.	PART NAME	MATERIAL
1.	LINED THERMOWELL	M.S. SS. 316
2.	LINNING THICKNESS 3.0 mm MAX. 5.0 mm MIN.	PTFE
SPARK TEST		15 KV D.C.

HSN CODE : 73061019

LINED THERMOWELL SIZE				
CAP.	NOZZLE SIZE	D Dia	F Dia	L
500L	100	76.1	220	1020
630L	100	76.1	220	1170
1000L	100	76.1	220	1410
1600L	100	76.1	220	1395
2000L	100	76.1	220	1595
2500L	100	76.1	220	1600
3000L	100	76.1	220	1760
4000L	150	114.3	285	2020
5000L	150	114.3	285	2420
6300L	150	114.3	285	2535

CLIENT NAME. _____

DRAWING NO. _____

ORDER NO. _____

FLOW-TEK VALVES & CONTROLS INC

PTFE DIP PIPE CUM SPARGER

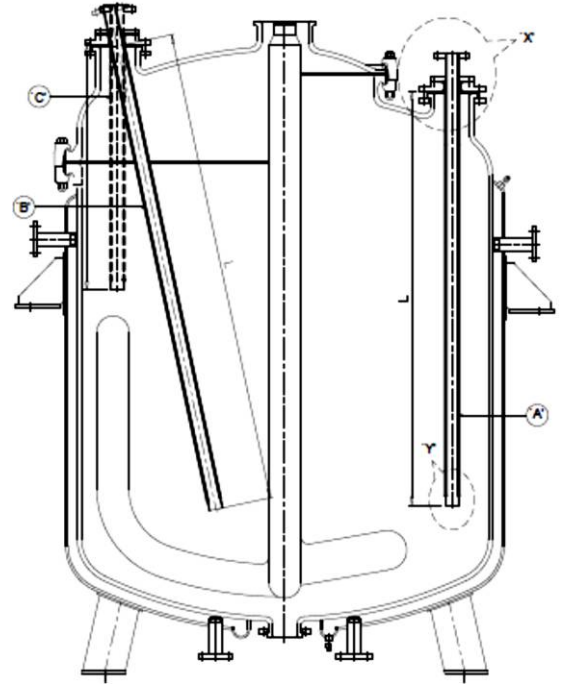
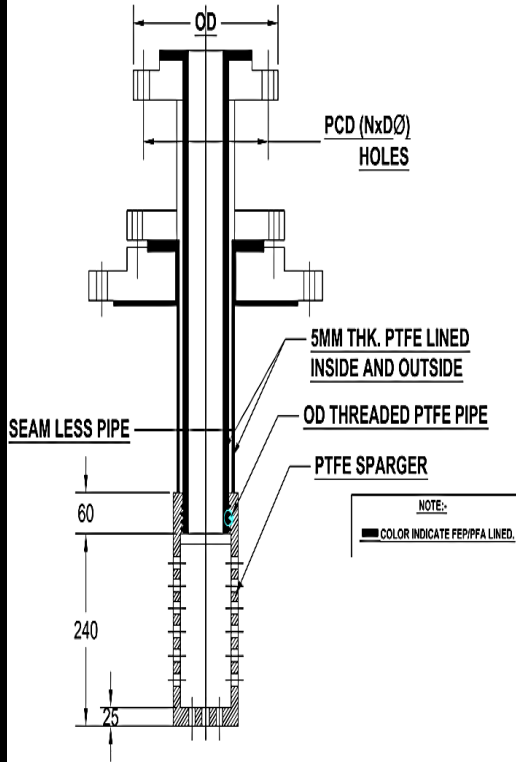

ALL DIMENSION ARE IN MM

SR NO.	PART NAME	MATERIAL
1.	PTFE DIP PIPE CUM SPARGER	M.S. SS. 316
2.	LINNING THICKNESS 3.0 mm MAX. 5.0 mm MIN.	PTFE
HYDRO TEST 10KG cm		SPARK TEST 15 KV D.C.

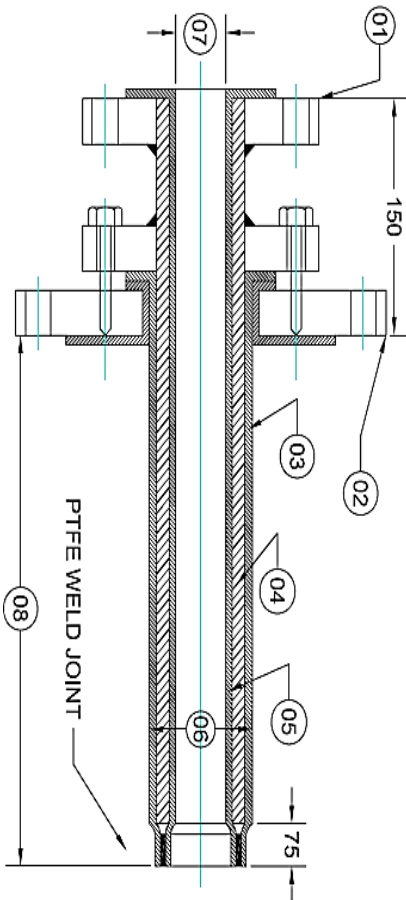

HSN CODE : 73061019

PTFE DIP PIPE CUM SPARGER SIZE				
CAP.	NOZZLE SIZE	Dip Pipe Size in NB	PCD/OD	L
160L	80 x 300	25	ASA 150#	648
250L	80 x 300	25	ASA 150#	800
500L	100 x 300	40	ASA 150#	920
630L	100 x 300	40	ASA 150#	1070
1000L	100 x 300	50	ASA 150#	1275
1600L	100 x 300	50	ASA 150#	1250
2000L	100 x 300	50	ASA 150#	1450
2500L	100 x 300	50	ASA 150#	1500
3000L	100 x 300	50	ASA 150#	1650
4000L	150 x 300	50	ASA 150#	1800
5000L	150 x 300	50	ASA 150#	2200
6300L	150 x 300	50	ASA 150#	2300
8000L	150 x 300	80	ASA 150#	2400
10000L	200 x 300	80	ASA 150#	2500
16000L	200 x 300	80	ASA 150#	2600
20000L	200 x 300	80	ASA 150#	2800

CLIENT NAME. _____

DRAWING NO. _____

ORDER NO. _____

FLOW-TEK VALVES & CONTROLS INC

PTFE GASKETS

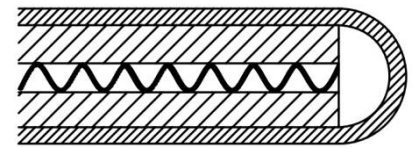
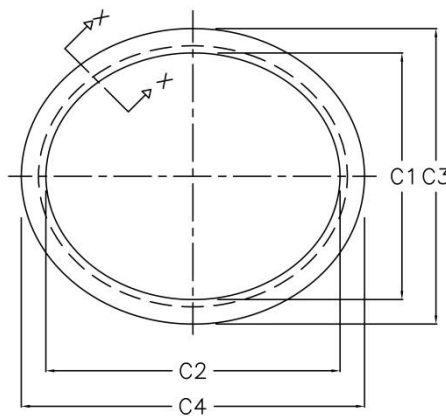
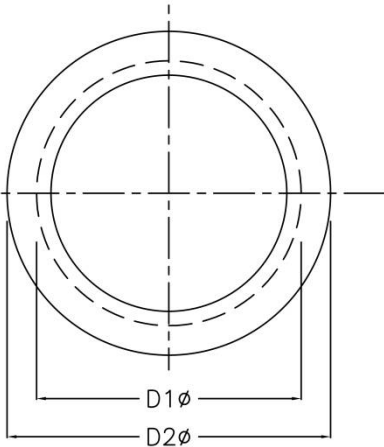

SECTION X-X

PTFE GASKETS ARE CORROSION RESISTANT OF FLUOROPOLYMER. PROVIDES RELIABLE SEALING & ALSO LONG SERVICE LIFE.

ALL DIMENSIONS ARE IN MM

SR NO.	PART NAME	MATERIAL
1.	PTFE GASKET	CHAMPION SHEET + THIN M.S. SHEET
2.	LINING THICKNESS 3.0 mm MAX. 5.0 mm MIN.	PTFE
	SPARK TEST	15 KV D.C.

HSN CODE : 84841090

FOR NOZZLE FLANGE						
Nom. DIA.	D1Ø	D2Ø	b	T		
25	39	65	9	5.2		
32	47	75	10	5.2		
40	59	85	9	5.2		
50	69	100	11.5	5.2		
65	80	120	16	5.2		
80	95	138	17.5	5.2		
100	119	158	15.5	5.2		
125	148	188	16	5.2		
150	169	212	17.5	5.2		
200	216	268	20.5	8.4		
250	266	220	21.5	8.4		
300	315	370	21.5	8.9		
400	415	482	27.5	8.9		
FOR BOTTOM VALVE NOZZLE FLANGE						
102/76	91	150	26.9	5.2		
150/100	137	190	22.5	5.2		
FOR MAIN BODY FLANGE						
500	510	565	20	12.1		
600	600	655	20	12.1		
700	700	775	30	12.1		
800	800	875	30	12.1		
1000	1000	1075	30	12.1		
1200	1200	1275	30	12.1		
1400	1400	1485	35	12.1		
1600	1600	1685	35	12.1		
1800	1800	1885	30	12.1		
2000	2000	2085	35	12.1		
2200	2200	2275	30	12.1		
FOR MANHOLE BODY FLANGE						
SIZE	C1	C2	C3	C4	b	T
500	-	-	521	605	37.5	8.9
350 x 450	366	466	430	530	25.7	8.9



CLIENT NAME. _____

DRAWING NO. _____

ORDER NO. _____

FLOW-TEK VALVES & CONTROLS INC

PTFE MANHOLE OR NOZZLE BUSHES

NOZZLE BUSH

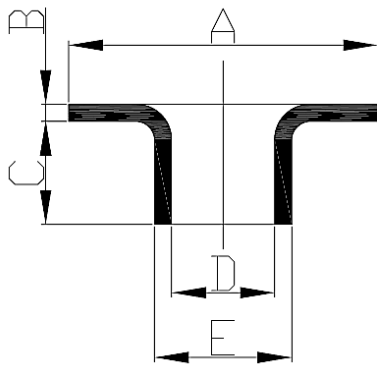

MAN HOLE BUSH

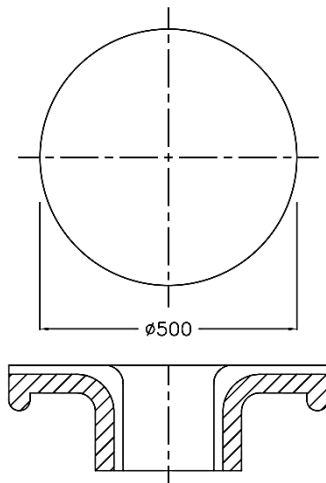

MAN HOLE BUSH

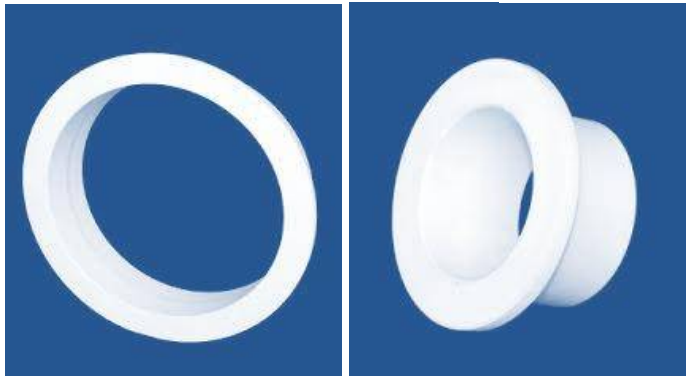
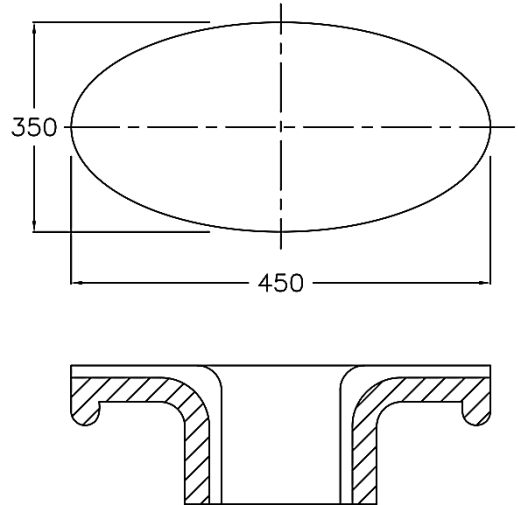

PTFE Nozzle bush provides protection against the effect of the shock of a hammer or wrench blow, thermal shock on radius & neck portion, thus protecting MS glass lined nozzle area.

ALL DIMENSION ARE IN MM

SR NO.	PART NAME	MATERIAL
1.	PTFE MANHOLE OR NOZZLE BUSHES	PTFE
2.	LINNING THICKNESS 12.0 mm MAX. 10.0 mm MIN.	PTFE

HSN CODE : 39169090

PTFE NOZZLE OR MANHOLE BUSHES SIZE

SIZE	A	B	C	D	E
50NB	100	10	90	38	52
65NB	120	10	90	53	67
80NB	140	10	90	68	82
100NB	160	10	90	88	102
125NB	190	10	90	113	127
150NB	215	10	90	138	152
200NB	270	10	90	188	202
250NB	320	10	90	238	252
300NB	370	10	90	288	302
350 x 450NB	530/430	10	90	430/330	452/352
400NB	480	10	90	388	402
500NB	605	10	90	488	502
600NB	710	10	90	588	602

CLIENT NAME. _____

DRAWING NO. _____

ORDER NO. _____

FLOW-TEK VALVES & CONTROLS INC

LINED MANHOLE COVER

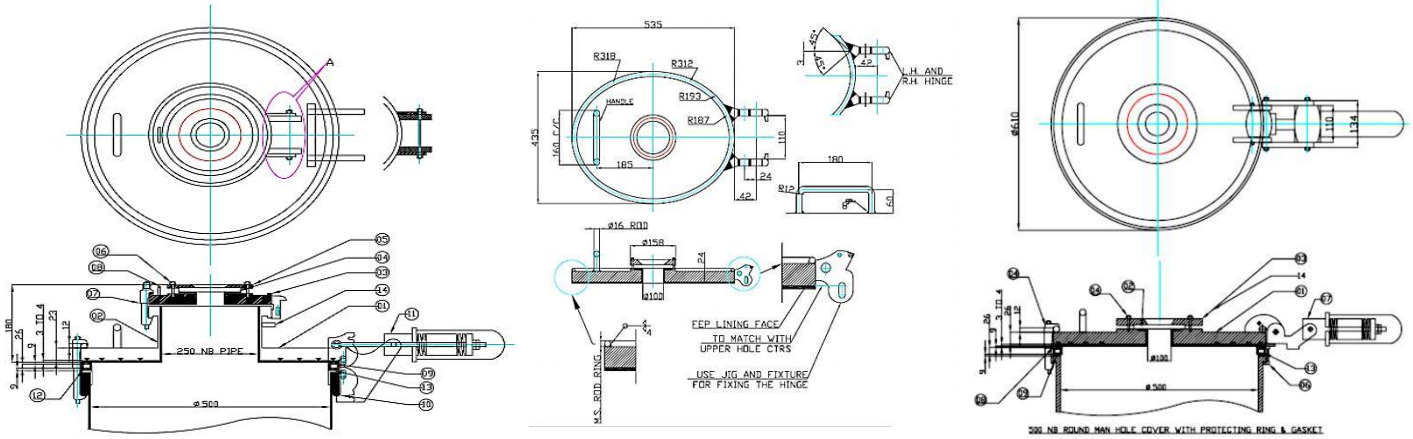

S.NO.	DESCRIPTION	QTY.	REMARKS
01	TEFLON FEP LINED COVER	01	
02	TEFLON FEP LINED CHARGING NOZZLE	01	
03	TEFLON FEP LINED FLANGE	01	
04	TOUGHEN GLASS 100NB	01	
05	OBSERVATION FLANGE	01	
06	HEX BOLT WITH WASHER SS-316	04	
07	FORGED 'C' CLAMP (WITH WING NUT)	04	
08	HANDLE	01	
09	TEFLON FEP LINED PROTECTING RING	01	
10	'J' BOLT WITH NUT & WASHER	04	
11	SPRING LOADED ASSEMBLY	01	
12	PTFE ENVELOPE GASKET	01	
13	PTFE ENVELOPE GASKET	01	
14	SS- WIRE ROPE 4MM DIA	01	
14	TEFLON FEP CONFORM TO ASTM-2116	01	



S.NO.	DESCRIPTION	QTY.	REMARKS
01	FEP LINED SS 304 COVER	01	
02	TOUGHEN GLASS 100NB	01	
03	OBSERVATION FLANGE SS 304	01	
04	HEX BOLT WITH WASHER SS-316	01	
05	FEP LINED SS 304 MANHOLE RING WITH LINGS	01	
06	SS 'J' BOLT WITH NUT & WASHER	04	
07	SPRING LOADED ASSEMBLY SS 304	04	
08	PTFE ENVELOPE GASKET	01	
09	PTFE ENVELOPE GASKET	01	
10	SS 'C' CLAMP ASSEMBLY SIZE M24x125lg	04	



ALL DIMENSION ARE IN MM

SR NO.	PART NAME	MATERIAL
1.	LINED MANHOLE COVER	M.S. SS. 316
2.	LINING THICKNESS 3.0 MM MAX. 5.0 MM MIN.	PFA
SPARK TEST		15 KV D.C.

HSN CODE : 73269099

LINED MANHOLE COVER SIZE

MS + FEP LINED / MS + PFA LINED / S.S 304 + FEP LINED / S.S 316 + PFA

LINED

SIZE (Ø)

100NB

150NB

200NB

250NB

350 x 450NB

500NB

600NB

CLIENT NAME. _____

DRAWING NO. _____

ORDER NO. _____

FLOW-TEK VALVES & CONTROLS INC

LINED PROTECTOR RING

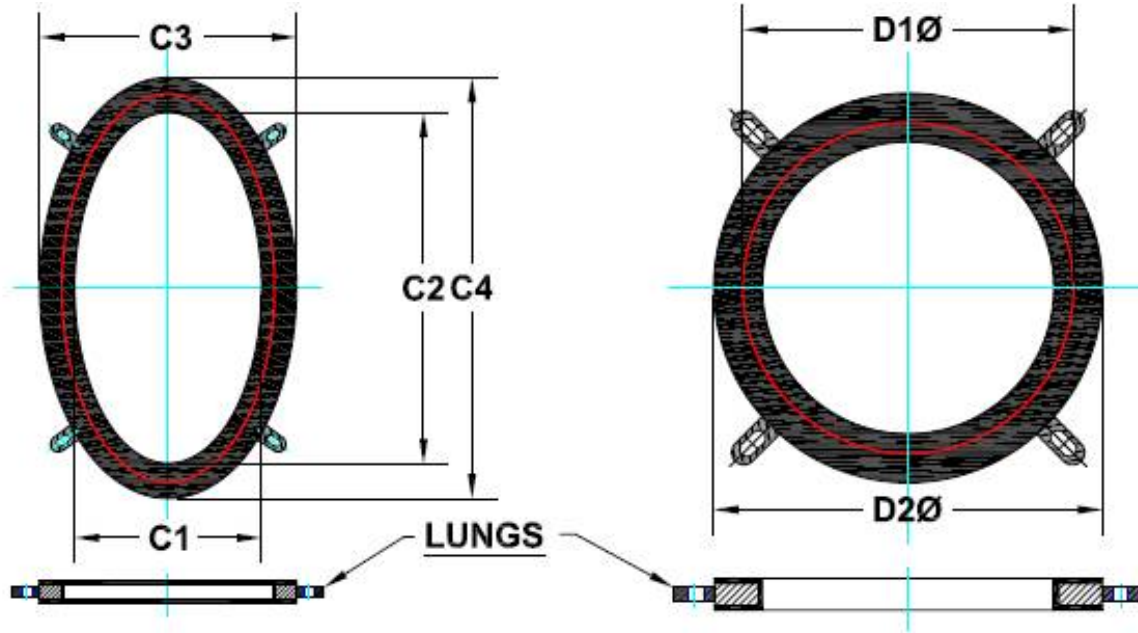

NOTE:-
 COLOR INDICATE FEP/PFA LINED.

ALL DIMENSION ARE IN MM

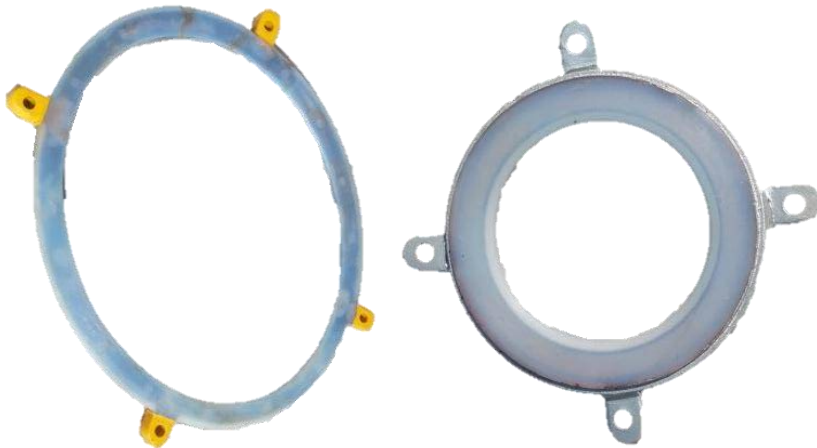

SR NO.	PART NAME	MATERIAL
1.	LINED PROTECTOR RING	M.S. SS. 316
2.	LINING THICKNESS 3.0 MM MAX. 5.0 MM MIN.	PFA
SPARK TEST		15 KV D.C.

HSN CODE : 73269099

LINED PROTECTOR RING SIZE	
MS + FEP LINED / MS + PFA LINED / S.S 304 + FEP LINED / S.S 316 + PFA LINED	
SIZE (Ø)	
100NB	
150NB	
200NB	
250NB	
350 x 450NB	
500NB	
600NB	

CLIENT NAME. _____
 DRAWING NO. _____
 ORDER NO. _____

FLOW-TEK VALVES & CONTROLS INC

LINED SPINDLE SPARES FOR FLUSH BOTTOM VALVE

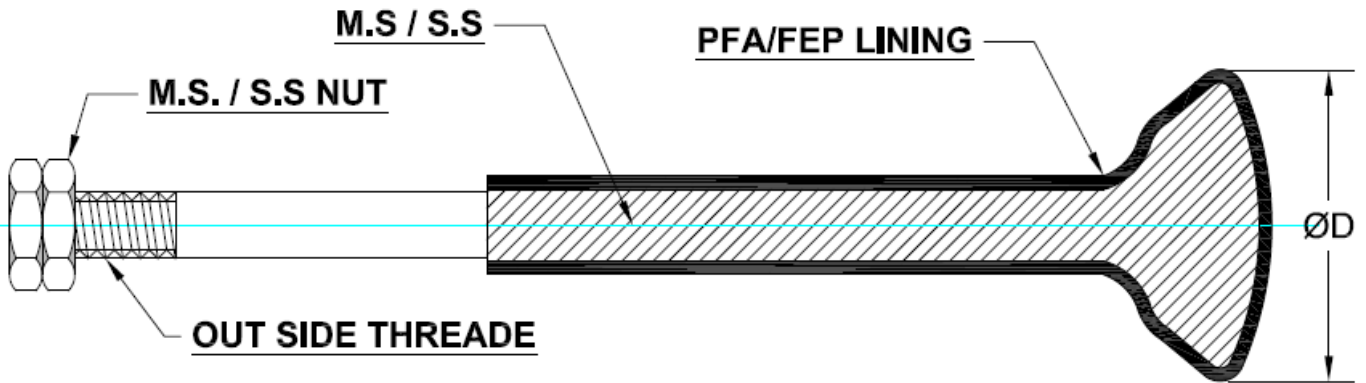

ALL DIMENSION ARE IN MM

SR NO.	PART NAME	MATERIAL
1.	LINED SPINDLE SPARE.	M.S. SS. 316
2.	LINNING THICKNESS 3.0 mm MAX. 5.0 mm MIN.	FEP / PFA
	SPARK TEST	15 KV D.C.

HSN CODE : 84818030

LINED SPINDLE SPARES SIZE	
MS + FEP LINED / S.S. 304 + FEP LINED / MS + PFA LINED / S.S. 316 + PFA LINED	
SIZE (Ø)	
	50 x 80mm
	80 x 100mm
	100 x 150mm
	200 x 150mm

CLIENT NAME. _____

DRAWING NO. _____

ORDER NO. _____

FLOW-TEK VALVES & CONTROLS INC

'C' CLAMP

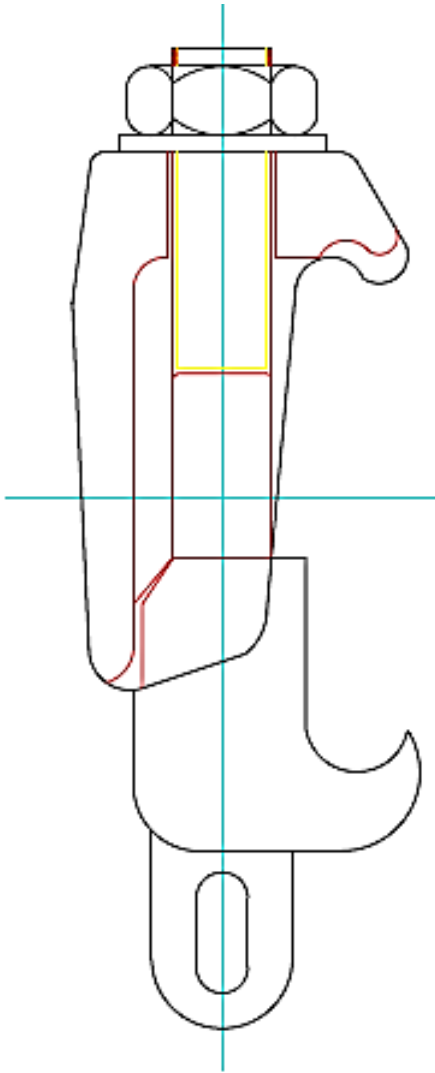

ALL DIMENSION ARE IN MM

HSN CODE : 82057000

SR NO.	PART NAME	MATERIAL	SIZE
1.	'C' CLAMP	M.S.	M 24
2.	'C' CLAMP	S.S 304	M 24
3.	'C' CLAMP	S.S 316	M 24

CLIENT NAME. _____

DRAWING NO. _____

ORDER NO. _____

FLOW-TEK VALVES & CONTROLS INC

SPLIT FLANGE

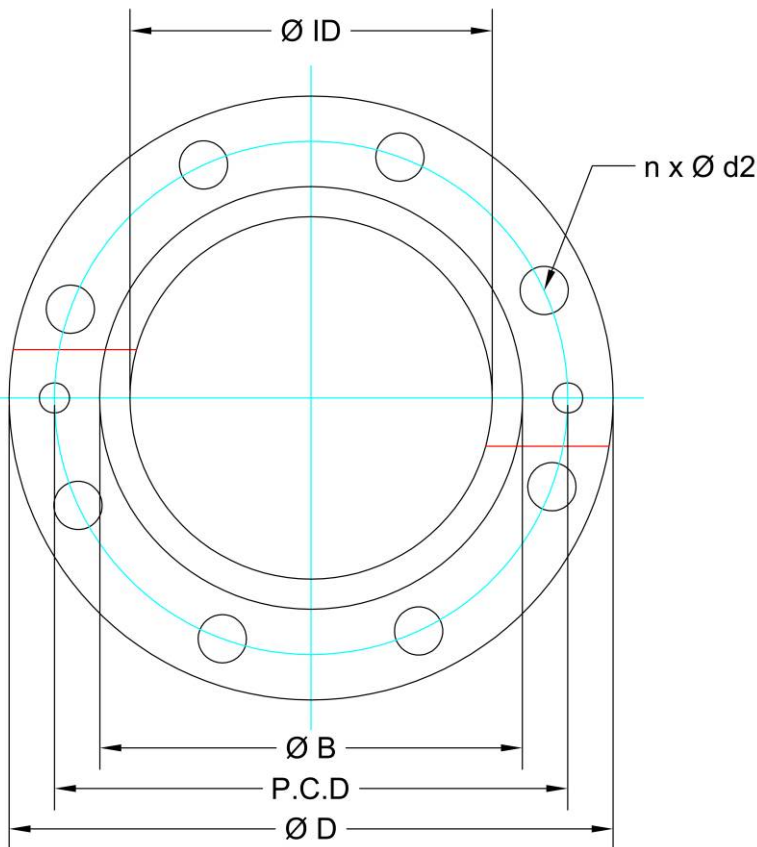

ALL DIMENSION ARE IN MM

SR NO.	PART NAME	MATERIAL
1.	SPLIT FLANGE	M.S. SS. 316 S.S 304

HSN CODE : 73072100

SPLIT FLANGE SIZE

NB	$\varnothing D$	$\varnothing B$	PCD	$n \times \varnothing d2$	$\varnothing ID$
25	115	68	85	4 x 14	40
32	140	78	100	4 x 18	47
40	150	88	110	4 x 18	55
50	165	100	125	4 x 18	67
65	185	122	145	4 x 18	80
80	200	138	160	8 x 18	95
100	220	158	180	8 x 18	115
125	250	188	210	8 x 18	140
150	285	212	240	8 x 23	165
200	340	268	295	8 x 23	225
250	405	320	355	12 x 27	276
300	460	370	410	12 x 27	227
400	580	482	525	16 x 30	410

CLIENT NAME. _____

DRAWING NO. _____

ORDER NO. _____

FLOW-TEK VALVES & CONTROLS INC

STUFFING BOX

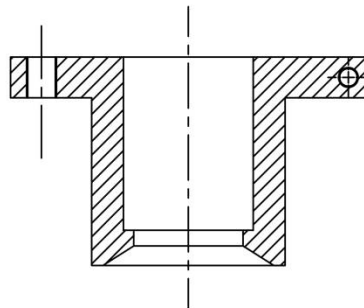
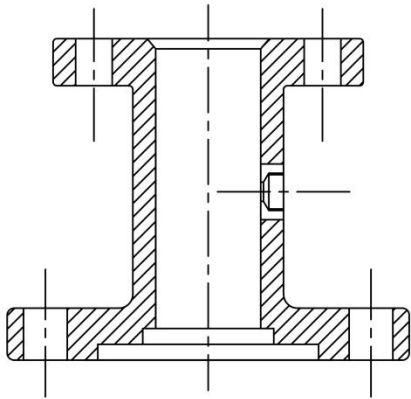
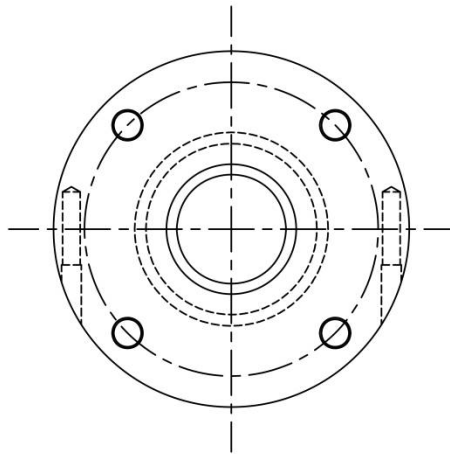
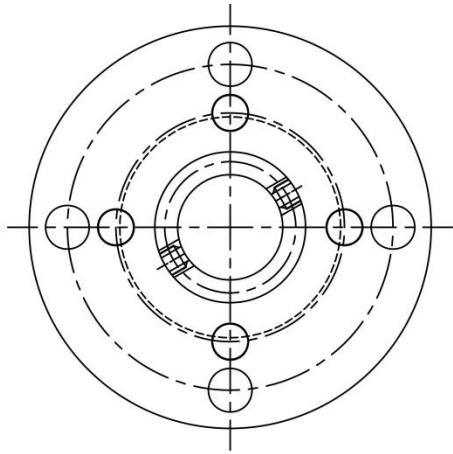

STUFFING BOX WITH GLAND
PUSHER

ALL DIMENSION ARE IN MM

SR NO.	PART NAME	MATERIAL
1.	STUFFING BOX	M.S. SS. 316 S.S 304

HSN CODE : 73269099

STUFFING BOX SIZE

Shaft DIA D	Cap.
60	500 to 1000kl
80	1600 to 4000kl
100	5000 to 8000kl
125	10000 to 12000kl

CLIENT NAME. _____

DRAWING NO. _____

ORDER NO. _____

FLOW-TEK VALVES & CONTROLS INC

LINED ADAPTOR RING

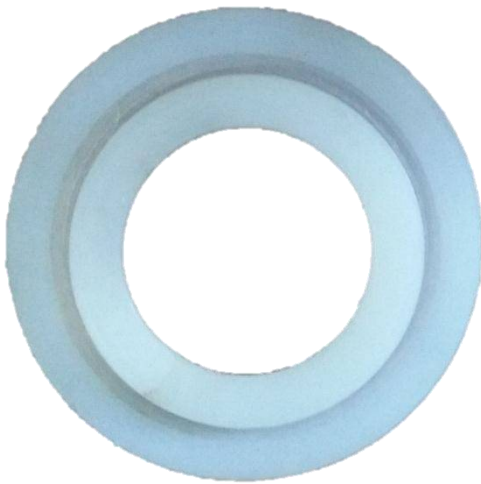
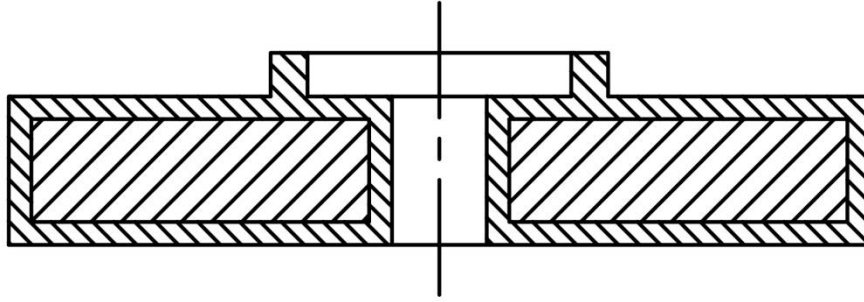

ALL DIMENSION ARE IN MM

SR NO.	PART NAME	MATERIAL
1.	LINED ADAPTOR RING	M.S. + PTFE / PFA / FEP SS. 316 + PTFE / PFA / FEP S.S 304 + PTFE / PFA / FEP

HSN CODE : 73269099

LINED ADAPTOR RING SIZE

Shaft DIA D	Cap.
60	500 to 1000kl
80	1600 to 4000kl
100	5000 to 8000kl
125	10000 to 12000kl

CLIENT NAME. _____

DRAWING NO. _____

ORDER NO. _____

FLOW-TEK VALVES & CONTROLS INC

LINED PAD PLATE

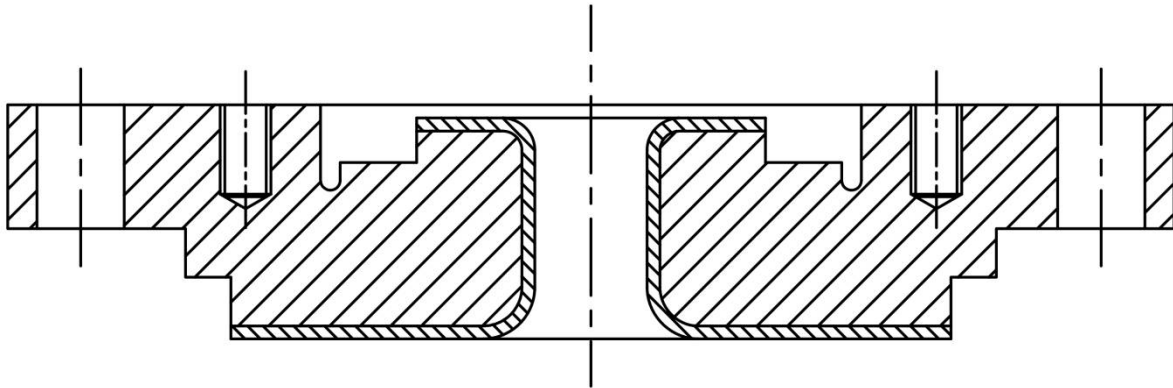

ALL DIMENSION ARE IN MM

SR NO.	PART NAME	MATERIAL
1.	LINED PAD PLATE	M.S. + PFA / FEP SS. 316 + PFA / FEP S.S 304 + PFA / FEP

HSN CODE : 73269099

LINED PAD PLATE SIZE

Shaft DIA D	Cap.
60	500 to 1000kl
80	1600 to 4000kl
100	5000 to 8000kl
125	10000 to 12000kl

CLIENT NAME. _____

DRAWING NO. _____

ORDER NO. _____

FLOW-TEK VALVES & CONTROLS INC

LINED MASHROOM DISH REPAIR KIT FOR GLASS LINED EQUIPMENTS

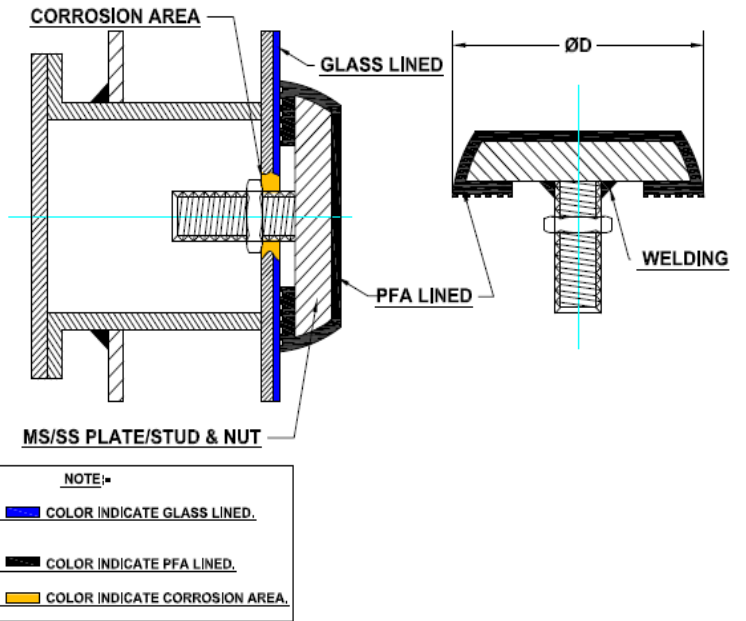
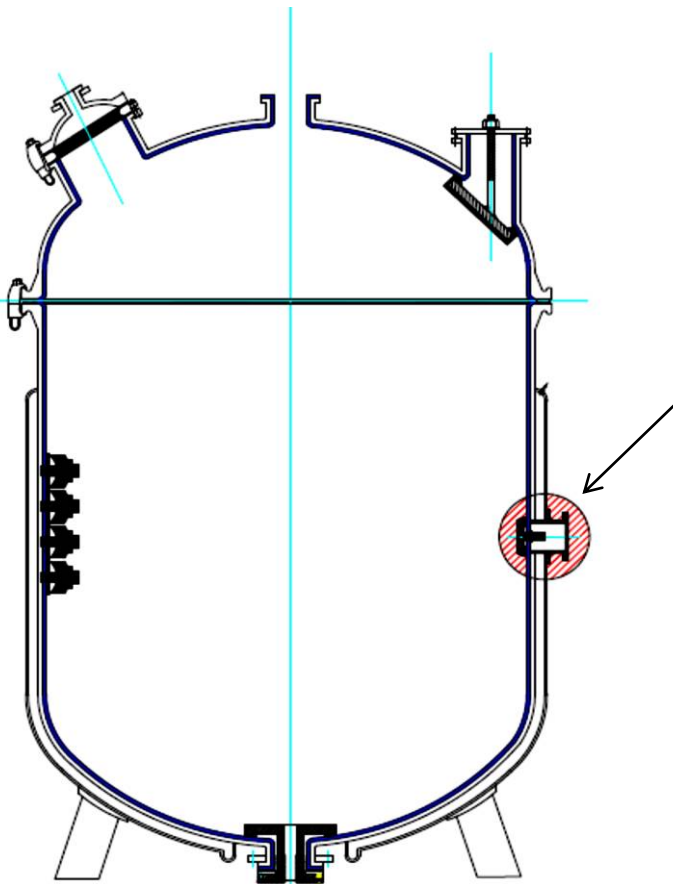

ALL DIMENSIONS ARE IN MM



HSN CODE : 82034090		
SR NO.	PART NAME	MATERIAL
1.	LINED MASHROOM DISH (USED IN GLASS LINED VESSEL REPAIRS)	M.S. SS. 316
2.	LINNING THICKNESS 5.0 mm MAX. 3.0 mm MIN.	PFA
SPARK TEST		15 KV D.C.

LINED MASHROOM DISH SIZE S.S. 316 /MS + PFA LINED SIZE (Ø)
50mm
65mm
75mm
100mm
125mm
150mm
175mm
200mm
225mm
250mm
275mm
300mm

CLIENT NAME. _____

DRAWING NO. _____

ORDER NO. _____

FLOW-TEK VALVES & CONTROLS INC

LINED BLIND DISH REPAIR KIT FOR GLASS LINED EQUIPMENTS

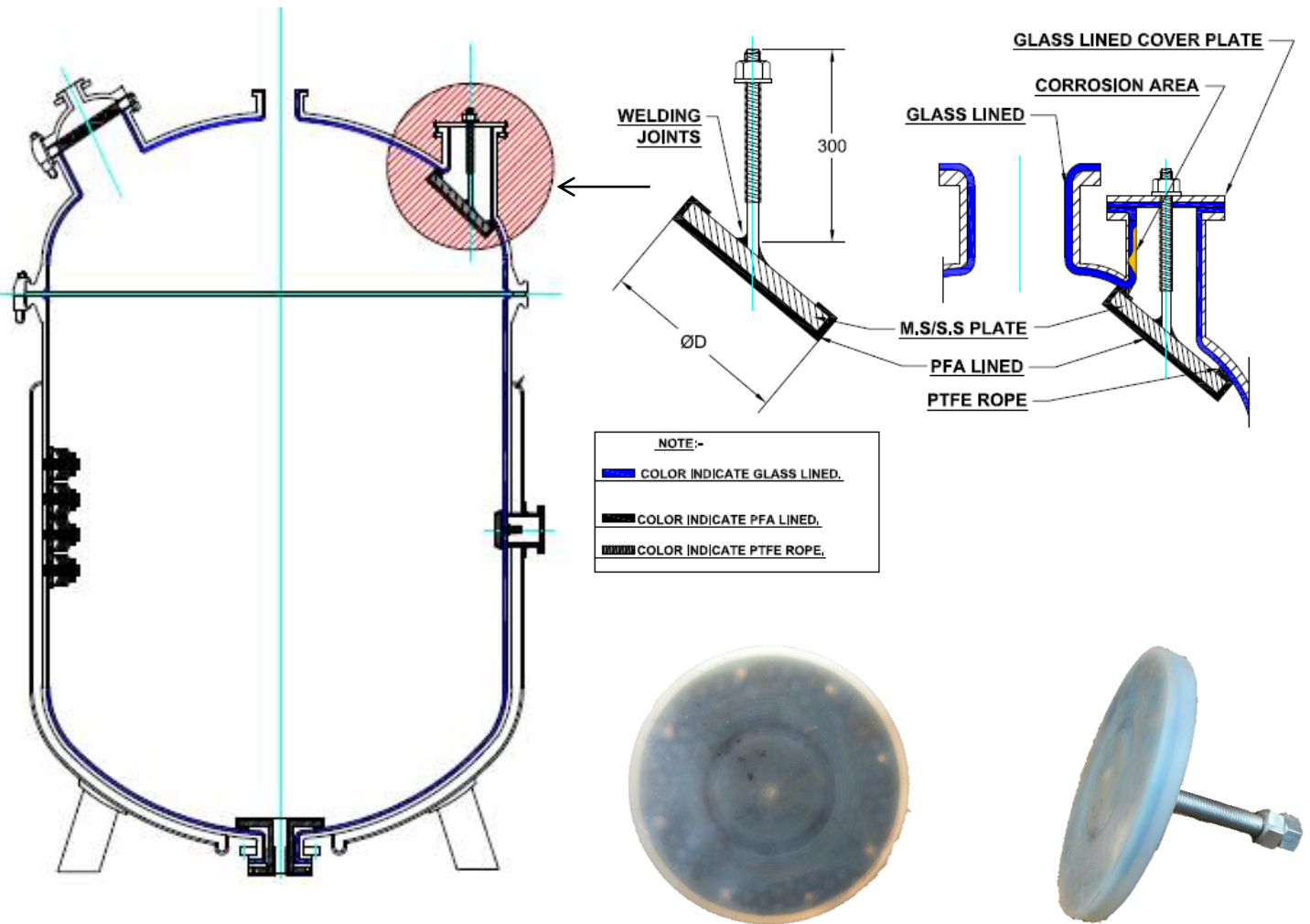

ALL DIMENTION ARE IN MM

HSN CODE : 82034090

SR NO.	PART NAME	MATERIAL
1.	LINED BLIND DISH. (USED IN GLASS LINE REPAIR)	M.S. SS. 316
2.	LINNING THICKNESS 3.0 mm MAX. 5.0 mm MIN.	PFA
SPARK TEST		15 KV D.C.

LINED BLIND DISH SIZE MS/ S.S. 316 + PFA LINED
SIZE (Ø)
150mm
200mm
250mm
300mm
350mm
400mm
450mm
500mm
550mm
600mm

CLIENT NAME. _____

DRAWING NO. _____

ORDER NO. _____

FLOW-TEK VALVES & CONTROLS INC

LINED DISH & BOLT REPAIR KIT FOR GLASS LINED EQUIPMENTS

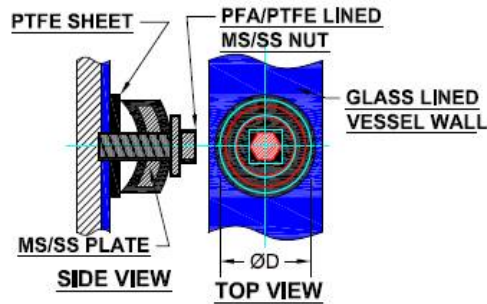
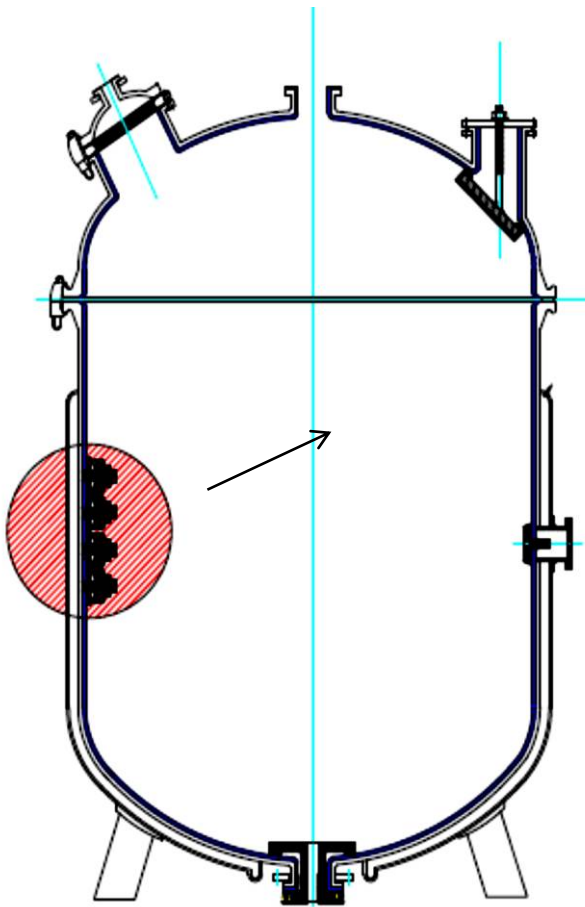

NOTE:-

 COLOR INDICATE GLASS LINED.

 COLOR INDICATE CORROSION AREA.

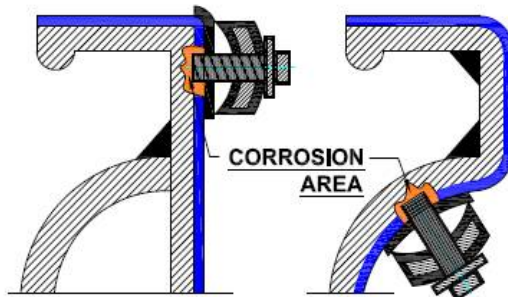

ALL DIMENTION ARE IN MM

HSN CODE : 82034090

SR NO.	PART NAME	MATERIAL
1.	LINED DISH AND BOLT (USED IN GLASS LINED VESSEL WALL REPAIR)	M.S. SS. 316
2.	LINNING THICKNESS 3.0 mm MAX. 5.0 mm MIN.	PFA PTFE
SPARK TEST		15 KV D.C.

LINED DISH & BOLT SIZE
MS / S.S 316 + PFA / PTFE LINED
SIZE
50mm
65mm
75mm
100mm
125mm
150mm
175mm
200mm
225mm
250mm
275mm
300mm

CLIENT NAME. _____



DRAWING NO. _____

ORDER NO. _____

FLOW-TEK VALVES & CONTROLS INC

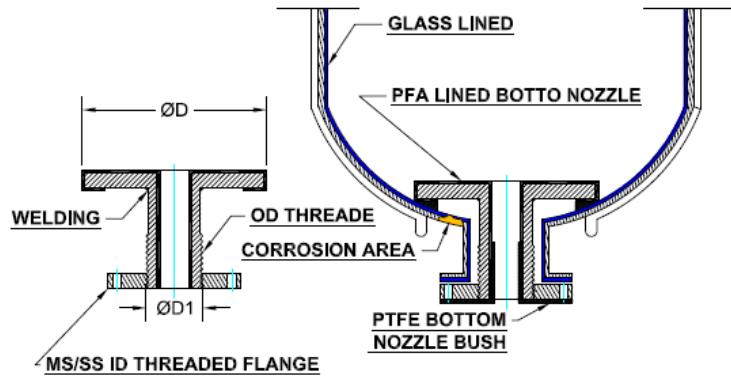
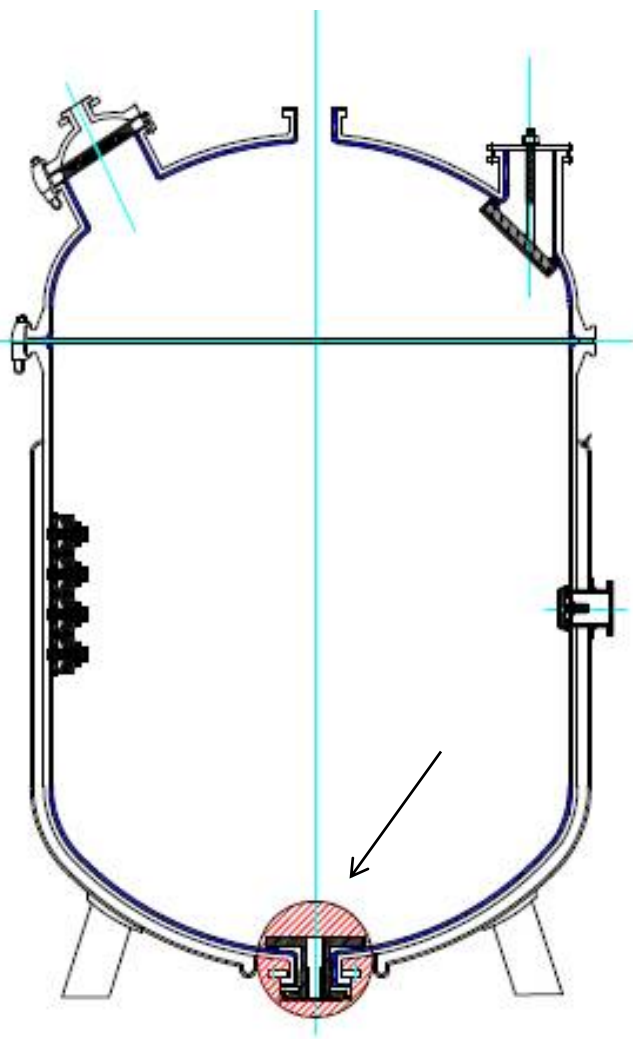
LINED BOTTOM NOZZLE REPAIR KIT FOR GLASS LINED EQUIPMENTS



NOTE:-
 COLOR INDICATE GLASS LINED.
 COLOR INDICATE PFA LINED.
 COLOR INDICATE PTFE ROB.



ALL DIMENSION ARE IN MM

HSN CODE : 82034090

LINED BOTTOM NOZZLE REPAIR KIT SIZE

MS + PFA LINED / S.S 316 + PFA LINED

SIZE 80NB (Ø)	SIZE 100NB (Ø)	SIZE 150 NB (Ø)	SIZE 200 NB (Ø)
80 x 150mm	100 x 150mm	150 x 250mm	200 x 250mm
80 x 200mm	100 x 200mm	150 x 300mm	200 x 300mm
80 x 250mm	100 x 250mm	150 x 350mm	200 x 350mm
80 x 300mm	100 x 300mm	150 x 400mm	200 x 400mm
80 x 350mm	100 x 350mm	150 x 450mm	200 x 450mm
80 x 400mm	100 x 400mm	150 x 500mm	200 x 500mm
80 x 450mm	100 x 450mm	150 x 550mm	200 x 550mm
80 x 500mm	100 x 500mm	150 x 600mm	200 x 600mm
80 x 550mm	100 x 550mm	-----	-----
80 x 600mm	100 x 600mm	-----	-----

SR NO.	PART NAME	MATERIAL
1.	LINED BOTTOM NOZZLE USED IN GLASS LINED REPAIR (USED IN GLASS LINED VESSEL BOTTOM REPAIR)	M.S. SS. 316
2.	LINING THICKNESS 3.0 mm MAX. 5.0 mm MIN.	PFA
SPARK TEST		15 KV D.C.

CLIENT NAME. _____

DRAWING NO. _____

ORDER NO. _____

FLOW-TEK VALVES & CONTROLS INC

AT YOUR SITE MAINTENANCE

TYPES OF REPAIR KIT FOR GLASS LINED EQUIPMENT

NOTE: Method and selection of size of repair material can be done on the basis of nature of damage, its area or location and size of the equipment.

1. LINED DISC AND BOLTS:

This is the most reliable method to seal pinhole and minor defects to protection by corrosion.

REPAIR PROCEDURES

LINED DISC AND BOLTS REPAIR KIT:

It covers small defects in lining. The Glass lining should be ground first to form a cavity of about 1.5mm larger than the diameter of the lined disc and bolt till the base metal is visible. Chipping during drilling/tapping occurs if metal is not exposed properly.

Cavity in lining can be formed by diamond abrasive burrs. Drill hole in body with the recommended drill according to size of tap.

While drilling/taping steel plate, care should be taken to make the hole at right angle to the PTFE disc and PFA lined bolt for better sealing. The drill or tap edge should not touch the lining around cavity otherwise it will damage the glass lining. PTFE sheet of about 0.5mm thickness is to be used with PTFE/PFA lined disc and bolt (**PTFE sheet used for entire covering corrosive or pinhole area more than the damages**). The depth of hole should be about 2.0mm more than the lined bolt for tight fittings. While lined bolting the defect on agitator, baffle type thermowell. Where base metal thickness is less, through hole is permitted. A layer of suitable cement is to be applied on the near cavity area and PTFE/lined disc before final fitting of lined bolt (**normally ALKOR furan resin base cement is used**).

FOR FURTHER PRODUCT DETAILS SEE PAGE NUMBER '54'.

2. LINED BLIND DISC:

This is suitable to protect by the chemical gases inside the nozzle pinhole damages and corrosive area which is not able to using condition. A lined blind disc dia up to 150mm can be fitted depending on the size of the glass lined reactor nozzle.

NOTE: After lined blind disc operation do to glass lined reactor top nozzle sealing permanently by lined blind disc. This means reactor nozzle unable for used any operation.

REPAIR PROCEDURES

LINED BLIND DISC REPAIR KIT:

On top of the reactor nozzle head cover by 8mm to 10mm thickness MS or SS plate which is choosing on chemical corrosive properties, same as the lined blind disc choose.

The size of the lined blind disc is to be decided only visualized corrosive and glass lined damage area And spark testing, as there are chances of increasing the damaged area during grinding and filling cement etc. lined blind disc plate minimum 8mm to 10mm lining inner metal thickness or on metal PFA lining minimum 6 to 8mm given. (Lined blind plate suitable metal chooses based on chemical corrosive application). Lined blind disc should cover at least 6/7mm sound lining.

Lined blind disc work, stud given 25/30mm more than the nozzle length which is tight fitting bolt to preventing chemical pressurized gases or liquid leakages. It is important to maintain center to center distance for the threaded stud throughout in top nozzle sealing solid plate hole on the item to be repaired; bend threaded stud in lined blind disc repair may create leakage. It is equally important to check the gap between each joint on repair patch. The lined blind disc work is Teflon glen at the bottom edge to joint with glass lining wall (end of the nozzle, around the curvature areas) for the better sealing and gripping on the lining.

Note: Teflon glen is used for better griping and sealing. It used to preventing leakages or handling vacuumed pressure.

FOR FURTHER PRODUCT DETAILS SEE PAGE NUMBER '53'.

3. LINED MUSHROOM DISC:

This is suitable for a mild service (where base metal thickness is less, through hole is required) and when no lined disc and bolt repair (patch work) is possible.

REPAIR PROCEDURES

LINED MUSHROOM DISC REPAIR KIT:

The repair process is similar to the lined blind dish. However, in this case, reversible Teflon ropes gasket is used instead of plain Teflon sheet for better sealing.

FOR FURTHER PRODUCT DETAILS SEE PAGE NUMBER '51'.

4. LINED BOTTOM NOZZLE:

Lined bottom nozzle it's a repair kit for using glass lined reactor bottom side nozzle area (out late nozzle) solution in which preventing the nozzle and near by the nozzle area damages. Like impact damage, pinholes damages, thermal damage, abrasion damage and corrosion damages.

NOTE: After lined Bottom nozzle operation do to glass lined reactor bottom nozzle is modifying new out late (internal diameter of the nozzle) which means nozzle area is reducing.

REPAIR PROCEDURES

LINED BOTTOM NOZZLE REPAIR KIT:

Lined bottom nozzle is selection based on size of corrosion area, damages area, type of corrosion application and type of damages. Type of corrosion application our company offering to you **MS + FEP/PFA** and **SS316 + FEP/PFA LINED BOTTOM NOZZLE** which is

Covered damages area and seals from chemical contact area. Lined Bottom nozzle plate diameter (**face diameter "D"**) based on covering corrosion and damages area which is covering nearby nozzle area. Lined bottom nozzle pipe length taken by the GLR bottom nozzle length (**L**) or internal diameter (**ID**). Lined bottom nozzle face area for batter gripping and sealing used Teflon rob. It may help to chemicals where not reach to damage area. On end of the nozzle tight fixed in right place for used mechanical sealing (lock nut) which helps to bottom nozzle stay in right position, it doesn't move in operation time.

Lined bottom nozzle operation it may require to lift the top cover of the GLR with agitator or COC cover during the repairing. After repairing reactor and agitator reassemble in its original position.

FOR FURTHER PRODUCT DETAILS SEE PAGE NUMBER '55'.

5. PTFE SHEET PATCH WORK:

Large and medium size of damage for used PTFE sheet patch work with MS/SS316 + FEP/PFA lined disc and bolt.

REPAIR PROCEDURES

PTFE SHEET DISC/PATCH WORK REPAIR KIT:

While drilling and tapping the same precautions should be observed. The diameter of disc or size of patch should be more than the defective lining. The size of the disc or patch is to be decided only after grinding the damaged area and spark testing , as there are chances of increasing the damaged area during grinding etc.

For PTFE patch work, numbers of lined (PFA/FEP) bolt are to be used. It is important to maintain center to center distance for the hole to be provided on the item to be repaired; oblong holes in PTFE sheet may create leakage. It is equally important to check the gap between each joint on repair patch. The sheet for patch work is to be round edges for better grip on lining.

FOR FURTHER PRODUCT DETAILS SEE PAGE NUMBER '54'.

6. REPAIRS BY PTFE T BUSH:

T bush protect glass lined nozzle & manhole cover collar from impact of over tight fitted pipe line, charging and preventing further corrosion in nozzle and elliptical, round manhole in all type of glass lined reactor glass lined reactor.

Damages on gasket sealing face and near curvature can be covered by using Teflon bush provided the damage is not deep ex. Right into the nozzle bore. If bush has tight fitting than the bore can be inserted into the nozzle with a flat blind M.S. Glass lined cover as fixing tool. Cement should be used along with bush.

FOR FURTHER PRODUCT DETAILS SEE PAGE NUMBER '43'.

FLOW-TEK VALVES & CONTROLS INC

AT OUR SITE MAINTENANCE

1. IMPELLER AGITATOR REPLACED BY LINED IMPELLER AGITATOR BLADE.

If your glass lined impeller agitator damaged in blade side area but shaft area in good condition (**doesn't damage**) so we recommended replace your damage glass lined impeller agitator blade are with **MS/SS316** with **FEP/PFA** lined agitator blade set (**fabrication work with PFA/FEP lining**) basically made with 3blade standard without disturbing agitator length and other parameters.

In case your impeller agitator blade part in good condition but your shaft part (**middle part of agitator**) is damaged so we can also solve the problem if on shaft had a pin hole or other minor corrosive problem so lined disc and bolt work solve them. Other side if shaft diameter had some major corrosion so that damaged part cut it or that cut shaft pipe replace and weld with new **SS316/MS** pipe (**suitable for chemical application**) and covering with PTFE tight fit pipe. Or on that tight fit PTFE pipe in case of operation doesn't movement for fixing lined bolting on it (**by threading & drilling operation**).

Or in case of your glass lined impeller agitator doesn't working condition (**highly corrosive damaged**) so **FLOW-TEK PRODUCTS** offers to you lined (**MS/SS316 + PFA/FEP**) impeller agitator your suitable application and as per requirement (**Glass lined reactor standard**).

FOR FURTHER PRODUCT DETAILS SEE PAGE NUMBER '38'.

2. IMPELLER ANCHOR AGITATOR REPLACED BY LINED IMPELLER ANCHOR -AGITATOR BLADE.

The repair process is similar to the lined impeller agitator. Also **FLOW-TEK PRODUCTS** offers to you lined (**MS/SS316 + PFA/FEP**) impeller anchor agitator your suitable application and as per requirement (**Glass lined reactor standard**).

FOR FURTHER PRODUCT DETAILS SEE PAGE NUMBER '39'.

3. THERMOWELL REPAIRS.

Thermowell can be repaired depends on its type of damage or damage areas.

If thermowell problem are occur so problem solution as solving bellow:-

1. Pinhole or minor corrosion for solution is lined dish and bolt to prevent the damages.
2. Major corrosion or glass lined thermowell shaft damages for glass lined damage shaft replace with suitable material like, (**MS/SS316**) or cover with **PTFE** tight fitting pipe. PTFE pipe doesn't sleep or movement for on a PTFE pipe lined bolting to fix a position.
3. If your glass lined thermowell bottom part isn't a damaged or shaft area were not in operating condition for we cut the bottom glass lined thermowell part or joint with suitable shaft (**MS/SS316**) and metal shaft covering with PTFE tube.

If a required lined thermowell so **FLOW-TEK PRODUCTS** offers to you lined thermowell (**MS/SS316 + PFA/FEP**) for your suitable application and as per requirement (**Glass lined reactor standard**).

FOR FURTHER PRODUCT DETAILS SEE PAGE NUMBER '40'.

4. MANHOLE REPAIRS.

Your glass lined reactor manhole cover is damage by the corrosion and unable to reuse. For that FLOW-TEK PRODUCTS providing you custom manufactured MS/SS316 with FEP/PFA lined manhole cover (**choosing material based on your plant suitable requirement or this custom manufacture manhole cover as per glass lined reactor standard.**)

FOR FURTHER PRODUCT DETAILS SEE PAGE NUMBER '44'.

5. AGITATOR MECHANICAL SEAL ATTACHMENT AREA AND GLAN AREA REPAIRS.

If your glass lined impeller agitator and anchor agitator mechanical seal attachment / glen portion area were damaged. For that FLOW-TEK PRODUCTS providing you finish HASTELLOY SLEEVING replace to fixing mechanical seal / glen portion attachment shaft damage area repair.

FOR FURTHER PRODUCT DETAILS SEE PAGE NUMBER '49, 50, 51'.



Flow-age

ISO 9001: 2015 CERTIFIED COMPANY

FLOW-TEK VALVES & CONTROLS INC.

**PLOT NO. 172-173, ROAD NO. 4,
KATHWADA GIDC, AHMEDABAD
382430, GUJARAT, INDIA.**

(M): +919824539702 / 9824080899

**(E): info@flowagevalves.com
hemal21386@gmail.com**

**MANUFACTURER OF:
CORROSION RESISTANT FLUOROPOLYMERS &
PLASTIC LINED PRODUCTS, PROVIDING THE
WIDE RANGE OF PTFE/PFA/FEP/PVDF/ & PP
LINED VALVES, PIPE AND PIPE FITTINGS.**

